

# WAVES AND COMPRESSIBLE FLOW

## LECTURE NOTES



BY PETER HOWELL

WITH MODIFICATIONS BY IAN HEWITT AND JIM OLIVER

HILARY TERM

# 1 Equations of motion

## 1.1 Introduction

We begin by deriving the equations of motion for an *inviscid* fluid, that is a fluid with zero viscosity. We treat the fluid as a *continuum*. This means that it can be described by a number of state variables, namely density  $\rho$ , velocity  $\mathbf{u}$ , pressure  $p$  and temperature  $T$ , all of which depend continuously on position  $\mathbf{x}$  and time  $t$ . In fact we assume throughout this section that  $\rho$ ,  $\mathbf{u}$ ,  $p$  and  $T$  are all continuously differentiable functions of  $\mathbf{x}$  and  $t$ . Later we will examine what happens when this assumption is relaxed, when analysing *shock waves*.

We start with the equations for incompressible flow, then introduce the *equation of state* to describe compressible flows, and the concept of *entropy*. Finally, we consider the equations of motion in a rotating frame, required for describing atmospheric and oceanic flows.

## 1.2 Reynolds' transport theorem

We begin by proving a theorem that will be very useful in deriving the equations representing conservation of mass, momentum and energy.

Consider a time-dependent volume  $V(t)$  that is convected by the fluid, so that it always consists of the same fluid particles. Then, for any function  $f(\mathbf{x}, t)$  that is continuously differentiable with respect to all of its arguments,

$$\frac{d}{dt} \iiint_{V(t)} f \, dV = \iiint_{V(t)} \frac{\partial f}{\partial t} + \nabla \cdot (f\mathbf{u}) \, dV. \quad (1.1)$$

We first give a simple-minded derivation of (1.1) before presenting a more rigorous proof, using Lagrangian variables, in section 1.3.

Denote by  $I(t)$  the integral on the left-hand side of (1.1), that is

$$I(t) = \iiint_{V(t)} f(\mathbf{x}, t) \, dV. \quad (1.2)$$

At some slightly later time  $t + \delta t$ , the integral is modified to

$$I(t + \delta t) = \iiint_{V(t+\delta t)} f(\mathbf{x}, t + \delta t) \, dV. \quad (1.3)$$

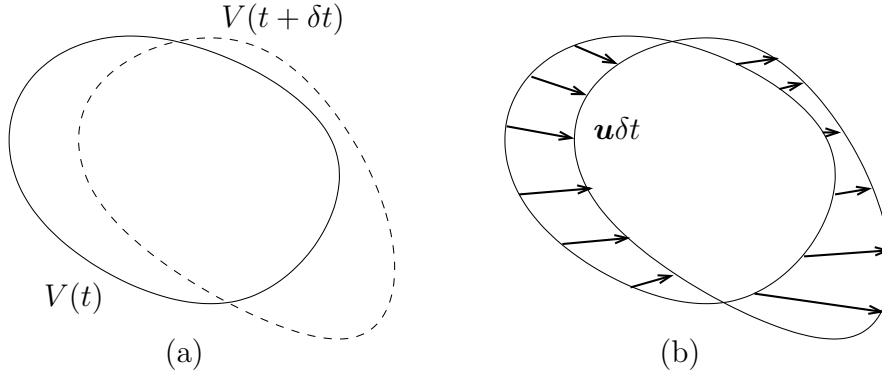

Figure 1.1: (a) A material volume  $V$  at times  $t$  and  $t + \delta t$ . (b) A schematic showing how the volume is swept out by the boundary with velocity  $\mathbf{u}$ .

It follows that

$$I(t + \delta t) - I(t) = \iiint_{V(t+\delta t)} f(\mathbf{x}, t + \delta t) - f(\mathbf{x}, t) dV + \iiint_{\delta V} f(\mathbf{x}, t) dV, \quad (1.4)$$

where  $\delta V = V(t + \delta t) \setminus V(t)$  is the volume swept out by the boundary  $\partial V$  in the small time  $\delta t$ .

As shown in figure 1.1,  $\delta V$  comprises thin shell whose thickness is approximately  $\mathbf{u} \cdot \mathbf{n} \delta t$ , where  $\mathbf{n}$  is the unit normal to  $\partial V$ . On the other hand, the first integral in (1.4) may be estimated by applying the mean value theorem to the integrand, so (1.4) implies that

$$\frac{I(t + \delta t) - I(t)}{\delta t} \sim \iiint_{V(t+\delta t)} \frac{\partial f}{\partial t}(\mathbf{x}, t) dV + \iint_{\partial V} f(\mathbf{x}, t) \mathbf{u} \cdot \mathbf{n} dS. \quad (1.5)$$

By letting  $\delta t \rightarrow 0$ , we obtain

$$\frac{dI}{dt} = \iiint_V \frac{\partial f}{\partial t} dV + \iint_{\partial V} f \mathbf{u} \cdot \mathbf{n} dS, \quad (1.6)$$

and application of the divergence theorem to the final integral leads to (1.1).

### 1.3 Lagrangian variables

For a more careful derivation of (1.1), we define *Lagrangian variables*  $\mathbf{X} = (X, Y, Z)$  as follows. At any time  $t$ , suppose the fluid element whose current position vector is  $\mathbf{x} = (x, y, z)$  was initially at position  $\mathbf{X}$ . As the fluid moves, the Lagrangian variables *follow the flow*, in that a fixed value of  $\mathbf{X}$  always corresponds to the same fluid particle for all time. In contrast, the *Eulerian variables*  $\mathbf{x}$  remain fixed in space as the fluid flows relative to them.

For this reason, the time derivative in the Lagrangian frame (*i.e.* with  $\mathbf{X}$  fixed) is referred to as the *convective derivative*, or the *material derivative* or simply the *derivative*

following the flow. It may be related to the normal Eulerian time derivative by using the chain rule, viz.

$$\frac{\partial f}{\partial t} \Big|_{\mathbf{X}} = \frac{\partial f}{\partial t} \Big|_{\mathbf{x}} + \frac{\partial x}{\partial t} \Big|_{\mathbf{X}} \frac{\partial f}{\partial x} + \frac{\partial y}{\partial t} \Big|_{\mathbf{X}} \frac{\partial f}{\partial y} + \frac{\partial z}{\partial t} \Big|_{\mathbf{X}} \frac{\partial f}{\partial z}, \quad (1.7)$$

where  $f$  is any continuously differentiable function of position and time.

Now, if we follow the fluid, then the rate of change of the (Eulerian) position vector  $\mathbf{x} = (x, y, z)$  is simply the velocity  $\mathbf{u} = (u, v, w)$ , so (1.7) may be written as

$$\frac{\partial f}{\partial t} \Big|_{\mathbf{X}} = \frac{\partial f}{\partial t} + u \frac{\partial f}{\partial x} + v \frac{\partial f}{\partial y} + w \frac{\partial f}{\partial z} = \frac{\partial f}{\partial t} + \mathbf{u} \cdot \nabla f, \quad (1.8)$$

where  $(\mathbf{u} \cdot \nabla)$  is shorthand for the directional derivative in the direction of  $\mathbf{u}$ , that is

$$(\mathbf{u} \cdot \nabla) \equiv u \frac{\partial}{\partial x} + v \frac{\partial}{\partial y} + w \frac{\partial}{\partial z}. \quad (1.9)$$

We use the notation

$$\frac{D}{Dt} = \frac{\partial}{\partial t} \Big|_{\mathbf{X}} = \frac{\partial}{\partial t} + (\mathbf{u} \cdot \nabla) \quad (1.10)$$

for the convective derivative, although  $d/dt$  is also common.

Now we transform the integral  $I(t)$  defined by (1.2) into Lagrangian variables to obtain

$$I(t) = \iiint_{V(t)} f \, dx \, dy \, dz = \iiint_{V(0)} f J \, dX \, dY \, dZ, \quad (1.11)$$

where

$$J = \frac{\partial(x, y, z)}{\partial(X, Y, Z)} \quad (1.12)$$

is the Jacobian of the transformation. In (1.11), the Lagrangian integral is over the fixed initial domain  $V(0)$  corresponding to the moving volume  $V(t)$ . We can therefore integrate through the integral as follows

$$\frac{dI}{dt} = \iiint_{V(0)} \frac{D}{Dt} (fJ) \, dX \, dY \, dZ, \quad (1.13)$$

where the time derivative is taken with the integration variables  $(X, Y, Z)$  held fixed.

Now we calculate  $DJ/Dt$  by differentiating the determinant row-by-row.

$$\begin{aligned} \frac{DJ}{Dt} = \frac{D}{Dt} \begin{vmatrix} \frac{\partial x}{\partial X} & \frac{\partial x}{\partial Y} & \frac{\partial x}{\partial Z} \\ \frac{\partial y}{\partial X} & \frac{\partial y}{\partial Y} & \frac{\partial y}{\partial Z} \\ \frac{\partial z}{\partial X} & \frac{\partial z}{\partial Y} & \frac{\partial z}{\partial Z} \end{vmatrix} &= \begin{vmatrix} \frac{D}{Dt} \left( \frac{\partial x}{\partial X} \right) & \frac{D}{Dt} \left( \frac{\partial x}{\partial Y} \right) & \frac{D}{Dt} \left( \frac{\partial x}{\partial Z} \right) \\ \frac{\partial y}{\partial X} & \frac{\partial y}{\partial Y} & \frac{\partial y}{\partial Z} \\ \frac{\partial z}{\partial X} & \frac{\partial z}{\partial Y} & \frac{\partial z}{\partial Z} \end{vmatrix} \\ &+ \begin{vmatrix} \frac{\partial x}{\partial X} & \frac{\partial x}{\partial Y} & \frac{\partial x}{\partial Z} \\ \frac{D}{Dt} \left( \frac{\partial y}{\partial X} \right) & \frac{D}{Dt} \left( \frac{\partial y}{\partial Y} \right) & \frac{D}{Dt} \left( \frac{\partial y}{\partial Z} \right) \\ \frac{\partial z}{\partial X} & \frac{\partial z}{\partial Y} & \frac{\partial z}{\partial Z} \end{vmatrix} + \begin{vmatrix} \frac{\partial x}{\partial X} & \frac{\partial x}{\partial Y} & \frac{\partial x}{\partial Z} \\ \frac{\partial y}{\partial X} & \frac{\partial y}{\partial Y} & \frac{\partial y}{\partial Z} \\ \frac{D}{Dt} \left( \frac{\partial z}{\partial X} \right) & \frac{D}{Dt} \left( \frac{\partial z}{\partial Y} \right) & \frac{D}{Dt} \left( \frac{\partial z}{\partial Z} \right) \end{vmatrix}. \end{aligned} \quad (1.14)$$

For convenience we denote the three determinants on the right-hand side of (1.14) by  $\Delta_1$ ,  $\Delta_2$  and  $\Delta_3$  respectively. Since the convective derivative is taken with  $\mathbf{X}$  fixed, it commutes with  $X$ -,  $Y$ - and  $Z$ -derivatives. Recalling also that  $Dx/Dt = u$ , we can rewrite  $\Delta_1$  as

$$\Delta_1 = \begin{vmatrix} \frac{\partial u}{\partial X} & \frac{\partial u}{\partial Y} & \frac{\partial u}{\partial Z} \\ \frac{\partial y}{\partial X} & \frac{\partial y}{\partial Y} & \frac{\partial y}{\partial Z} \\ \frac{\partial z}{\partial X} & \frac{\partial z}{\partial Y} & \frac{\partial z}{\partial Z} \end{vmatrix}. \quad (1.15)$$

We apply the chain rule to each of the derivatives in the first row to obtain

$$\Delta_1 = \frac{\partial u}{\partial x} \begin{vmatrix} \frac{\partial x}{\partial X} & \frac{\partial x}{\partial Y} & \frac{\partial x}{\partial Z} \\ \frac{\partial y}{\partial X} & \frac{\partial y}{\partial Y} & \frac{\partial y}{\partial Z} \\ \frac{\partial z}{\partial X} & \frac{\partial z}{\partial Y} & \frac{\partial z}{\partial Z} \end{vmatrix} + \frac{\partial u}{\partial y} \begin{vmatrix} \frac{\partial y}{\partial X} & \frac{\partial y}{\partial Y} & \frac{\partial y}{\partial Z} \\ \frac{\partial y}{\partial X} & \frac{\partial y}{\partial Y} & \frac{\partial y}{\partial Z} \\ \frac{\partial z}{\partial X} & \frac{\partial z}{\partial Y} & \frac{\partial z}{\partial Z} \end{vmatrix} + \frac{\partial u}{\partial z} \begin{vmatrix} \frac{\partial z}{\partial X} & \frac{\partial z}{\partial Y} & \frac{\partial z}{\partial Z} \\ \frac{\partial y}{\partial X} & \frac{\partial y}{\partial Y} & \frac{\partial y}{\partial Z} \\ \frac{\partial z}{\partial X} & \frac{\partial z}{\partial Y} & \frac{\partial z}{\partial Z} \end{vmatrix}. \quad (1.16)$$

The final two determinants in (1.16) have repeated rows and are therefore identically zero. It follows that

$$\Delta_1 = \frac{\partial u}{\partial x} J, \quad (1.17)$$

and analogous manipulations lead to

$$\Delta_2 = \frac{\partial v}{\partial y} J, \quad \Delta_3 = \frac{\partial w}{\partial z} J. \quad (1.18)$$

By substituting these into (1.14), we obtain *Euler's identity*

$$\frac{DJ}{Dt} = J \nabla \cdot \mathbf{u}. \quad (1.19)$$

Now we expand out the derivative in (1.13) and use (1.19) to obtain

$$\frac{dI}{dt} = \iiint_{V(0)} \left( \frac{Df}{Dt} + f \nabla \cdot \mathbf{u} \right) J dXdYdZ = \iiint_{V(t)} \frac{Df}{Dt} + f \nabla \cdot \mathbf{u} dx dy dz. \quad (1.20)$$

The definition (1.10) of the convective derivative then leads to Reynolds' Transport Theorem (1.1).

## 1.4 Conservation of mass

As a first application of (1.1), consider the mass  $M$  of a volume  $V(t)$  that moves with the fluid, namely

$$M = \iiint_{V(t)} \rho dV, \quad (1.21)$$

where  $\rho$  is the density. Since mass can be neither created nor destroyed,  $M$  must be constant in time, that is

$$0 = \frac{dM}{dt} = \iiint_V \frac{\partial \rho}{\partial t} + \nabla \cdot (\rho \mathbf{u}) dV. \quad (1.22)$$

Since the volume  $V(t)$  is arbitrary, we deduce that the integrand must be zero (assuming it is continuous), that is

$$\frac{\partial \rho}{\partial t} + \nabla \cdot (\rho \mathbf{u}) = 0. \quad (1.23)$$

We can use (1.23) to deduce the following useful corollary of the transport theorem. If  $f = \rho h$  in (1.1), where  $h$  is any continuously differentiable function, then

$$\frac{d}{dt} \iiint_{V(t)} \rho h dV = \iiint_{V(t)} \rho \frac{Dh}{Dt} dV. \quad (1.24)$$

## 1.5 Conservation of momentum

Next we apply Newton's second law, namely "rate of change of momentum equals applied force" to a material volume  $V(t)$ . The net momentum of such a volume is

$$\iiint_V \rho \mathbf{u} dV,$$

while the applied force has two ingredients. First there is the *external* body force, assumed to be solely due to gravitational acceleration  $\mathbf{g}$ , which contributes a net force

$$\iiint_V \rho \mathbf{g} dV.$$

Second there is the *internal* force exerted on each volume  $V$  by the surrounding fluid. We suppose that this may be accounted for by a *pressure*,  $p$ , which acts in the inward normal direction at each point, so the net internal force on  $V$  is

$$\iint_{\partial V} -p\mathbf{n} \, dS = \iiint_V -\nabla p \, dV,$$

using a well-known corollary of the divergence theorem. Here we have assumed that the fluid is *inviscid*: a viscous fluid would transmit tangential as well as normal internal forces.

Now we can formulate Newton's second law in the form

$$\frac{d}{dt} \iiint_V \rho \mathbf{u} \, dV = \iiint_V -\nabla p \, dV + \iiint_V \rho \mathbf{g} \, dV. \quad (1.25)$$

To calculate the left-hand side, we apply the transport theorem corollary (1.24) and hence obtain

$$\iiint_V \rho \frac{D\mathbf{u}}{Dt} + \nabla p - \rho \mathbf{g} \, dV = \mathbf{0}, \quad (1.26)$$

which must hold for all material volumes  $V$ . It follows that (assuming it is continuous) the integrand must be zero, and we therefore obtain the momentum equation

$$\rho \frac{D\mathbf{u}}{Dt} = -\nabla p + \rho \mathbf{g}, \quad (1.27)$$

which is often known as *Euler's equation*.

## 1.6 Potential flow

So far we have derived (1.23) and the vector equation (1.27) representing conservation of mass and momentum respectively. These comprise four scalar equations in total, although  $\rho$ ,  $p$  and the three components of  $\mathbf{u}$  give us five unknown dependent variables. It is clear, therefore, that we need one more piece of information to obtain a well posed problem. The simplest additional assumption is that the fluid is *incompressible*, meaning that the density  $\rho$  of each fluid element is constant, expressed by

$$\frac{D\rho}{Dt} = 0. \quad (1.28)$$

Often, but not necessarily,  $\rho$  takes the same known constant throughout the fluid (which is a stronger statement than (1.28)). The assumption of incompressibility is a good approximation for most liquids, whose densities typically do not vary much unless they are subjected to very high pressure. Gases, though, are relatively easy to compress, and (as we shall see) well-known phenomena such as sound waves and shock waves behind supersonic aircraft cannot be explained without considering compressibility effects.

Mass conservation (1.23) now reduces to

$$\nabla \cdot \mathbf{u} = 0, \quad (1.29)$$

which, along with (1.27), this gives us four equations for  $p$  and the three components of  $\mathbf{u}$ .

The problem is simplified further if we assume that the flow is *irrotational*, meaning that

$$\nabla \times \mathbf{u} = \mathbf{0}. \quad (1.30)$$

If this is true, then there must exist a *velocity potential*  $\phi$  such that

$$\mathbf{u} = \nabla \phi. \quad (1.31)$$

By substituting this into (1.29), we find that  $\phi$  satisfies *Laplace's equation*

$$\nabla^2 \phi = 0. \quad (1.32)$$

Given suitable boundary conditions, (1.32) allows us to determine  $\phi$  and hence the velocity  $\mathbf{u}$ , and the pressure is then found from (1.27). This final step may be simplified as follows. The gravitational body force  $\mathbf{g}$  is conservative and so may be described using a gravitational potential function  $\chi$  such that

$$\mathbf{g} = -\nabla \chi. \quad (1.33)$$

(For example, if  $\mathbf{g} = -g\mathbf{e}_z$  as usual, then  $\chi = gz$ .) We also expand out the convective derivative on the left-hand side of (1.27) to obtain

$$\frac{\partial \mathbf{u}}{\partial t} + (\mathbf{u} \cdot \nabla) \mathbf{u} = -\frac{1}{\rho} \nabla p - \nabla \chi. \quad (1.34)$$

On the left-hand side, we use the vector identity

$$(\mathbf{u} \cdot \nabla) \mathbf{u} \equiv \nabla \left( \frac{1}{2} |\mathbf{u}|^2 \right) + (\nabla \times \mathbf{u}) \times \mathbf{u}, \quad (1.35)$$

which is readily established by taking components. By substituting this into (1.34) and using (1.31), we obtain

$$\frac{\partial \nabla \phi}{\partial t} + \nabla \left( \frac{1}{2} |\nabla \phi|^2 \right) = -\frac{1}{\rho} \nabla p - \nabla \chi. \quad (1.36)$$

Since the  $t$ -derivative commutes with  $\nabla$  and  $\rho$  is constant, we can rearrange this to

$$\nabla \left\{ \frac{\partial \phi}{\partial t} + \frac{1}{2} |\nabla \phi|^2 + \frac{p}{\rho} + \chi \right\} = \mathbf{0}. \quad (1.37)$$

It follows that the quantity in braces can be a function only of  $t$ , that is

$$\frac{\partial \phi}{\partial t} + \frac{1}{2} |\nabla \phi|^2 + \frac{p}{\rho} + \chi = F(t), \quad (1.38)$$

which is known as *Bernoulli's equation*.



In (1.38), the function  $F(t)$  may be chosen arbitrarily to make the equations as convenient as possible. This is because the velocity potential is only defined up to an arbitrary function of  $t$ ; if we define

$$\phi = \tilde{\phi} + f(t), \quad (1.39)$$

then  $\tilde{\phi}$  is a potential corresponding to exactly the same velocity field through (1.31). In addition, (1.38) then becomes

$$\frac{\partial \tilde{\phi}}{\partial t} + \frac{1}{2} |\nabla \tilde{\phi}|^2 + \frac{p}{\rho} + \chi = F(t) - f'(t) \quad (1.40)$$

so we can, for example, obtain (1.38) with  $F(t) \equiv 0$  by choosing  $f'(t) = F(t)$ .

Finally, we should ask ourselves whether it is reasonable to assume that the flow is irrotational. We will now justify this assumption by showing that, if the flow is irrotational initially, then it is so for all time. We will do so by first establishing *Kelvin's circulation theorem*, for a closed curve  $C(t)$  that is convected by the flow. We define the *circulation* around such a curve by

$$\Gamma(t) = \oint_{C(t)} \mathbf{u} \cdot d\mathbf{x} = \iint_{S(t)} (\nabla \times \mathbf{u}) \cdot \mathbf{n} \, dS, \quad (1.41)$$

where  $S$  is any surface spanning  $C$ , the latter identity following by Stokes' theorem. Kelvin's theorem states that  $\Gamma$  is independent of  $t$ , and we will prove it by showing that  $d\Gamma/dt$  is zero.

To differentiate  $\Gamma$ , it is helpful to transform the integral to Lagrangian variables, using the chain rule. We follow the *summation convention*, in which summation is assumed over any repeated suffix, to obtain

$$\frac{d\Gamma}{dt} = \frac{d}{dt} \oint_{C(t)} u_i \, dx_i = \frac{d}{dt} \oint_{C(0)} u_i \frac{\partial x_i}{\partial X_j} \, dX_j = \oint_{C(0)} \frac{D}{Dt} \left( u_i \frac{\partial x_i}{\partial X_j} \right) \, dX_j, \quad (1.42)$$

where we hold the integration variables  $\mathbf{X}$  constant when differentiating through the integral. We expand out the derivative in the integrand, using the fact that  $D/Dt$  commutes with  $\partial/\partial X_j$ , to obtain

$$\frac{d\Gamma}{dt} = \oint_{C(0)} \frac{Du_i}{Dt} \frac{\partial x_i}{\partial X_j} + u_i \frac{\partial u_i}{\partial X_j} \, dX_j = \oint_{C(0)} \frac{Du_i}{Dt} \, dx_i + \oint_{C(t)} u_i \, du_i. \quad (1.43)$$

The second integral here can be performed immediately, and we use (1.34) to substitute for the acceleration in the first integral:

$$\frac{d\Gamma}{dt} = - \oint_{C(t)} \frac{\partial}{\partial x_i} \left( \frac{p}{\rho} + \chi \right) \, dx_i + \left[ \frac{u_i^2}{2} \right]_{C(t)} = \left[ -\frac{p}{\rho} - \chi + \frac{1}{2} |\mathbf{u}|^2 \right]_{C(t)}, \quad (1.44)$$

where  $[\cdot]_{C(t)}$  denotes the change in  $\cdot$  as the closed loop  $C$  is traversed. Since  $p$ ,  $\chi$  and  $\mathbf{u}$  are all single-valued functions of position, we deduce that the right-hand side is zero and, hence, that  $\Gamma$  is constant.

Now, we can use this property to show that an initially irrotational flow remains irrotational for all time. Suppose for contradiction that  $\nabla \times \mathbf{u} = \mathbf{0}$  at  $t = 0$  but that  $\nabla \times \mathbf{u}$  is nonzero at some later time  $t$ . By (1.41), we can thus find a closed loop  $C(t)$  such that the circulation  $\Gamma(t)$  is nonzero. Since  $\Gamma$  is independent of  $t$ ,  $\Gamma(0)$  must likewise be nonzero, which is impossible because  $\nabla \times \mathbf{u}$  was supposed to be zero initially.

## 1.7 The energy equation

If we do not assume that the density is constant, then (1.23) and (1.27) are insufficient to determine  $\rho$ ,  $\mathbf{u}$  and  $p$ . We obtain a further equation by applying the principle of conservation of energy as follows. The total energy contained in a material volume  $V(t)$  consists of the kinetic energy and the thermal energy, given by

$$\iiint_V \frac{1}{2} \rho |\mathbf{u}|^2 dV \quad \text{and} \quad \iiint_V \rho c_v T dV$$

respectively, where  $T$  is the absolute temperature (*i.e.* relative to absolute zero) and  $c_v$  is the *specific heat*. In SI units,  $c_v$  is the energy required to raise a kilogram of fluid by one degree in temperature, while keeping the volume constant. We will assume throughout that  $c_v$  is constant although, in general, it may depend on temperature.

The internal energy changes due to the work done by the external body force  $\mathbf{g}$  and by the pressure on the boundary of  $V$ ; these are respectively given by

$$\iiint_V \rho \mathbf{g} \cdot \mathbf{u} dV \quad \text{and} \quad \iint_{\partial V} -p \mathbf{u} \cdot \mathbf{n} dS.$$

Energy may also flow through  $\partial V$  by thermal conduction. Fourier's law of conduction gives the heat flux into  $V$  as

$$\iint_{\partial V} k \nabla T \cdot \mathbf{n} dS,$$

where  $k$  is the thermal conductivity. Finally, we allow for internal production of thermal energy (by, for example, microwave heating) at a rate  $q$  per unit mass.

Putting all these effects together, we arrive at the equation

$$\begin{aligned} \frac{d}{dt} \iiint_V \frac{1}{2} \rho |\mathbf{u}|^2 + \rho c_v T dV = & \iiint_V \rho \mathbf{g} \cdot \mathbf{u} dV - \iint_{\partial V} p \mathbf{u} \cdot \mathbf{n} dS \\ & + \iint_{\partial V} k \nabla T \cdot \mathbf{n} dS + \iiint_V \rho q dV, \end{aligned} \quad (1.45)$$

representing net conservation of energy. By using the transport theorem and the divergence theorem, we rewrite this equation as

$$\iiint_V \left\{ \rho \mathbf{u} \cdot \frac{D\mathbf{u}}{Dt} + \rho c_v \frac{DT}{Dt} - \rho \mathbf{g} \cdot \mathbf{u} + \nabla \cdot (p\mathbf{u}) - \nabla \cdot (k\nabla T) - \rho q \right\} dV = 0, \quad (1.46)$$

which must hold for all material volumes  $V(t)$ . It follows that the integrand, if continuous, must be identically zero. The resulting energy equation may be simplified further by using (1.27), leading to

$$\rho c_v \frac{DT}{Dt} = -p \nabla \cdot \mathbf{u} + \nabla \cdot (k \nabla T) + \rho q. \quad (1.47)$$

Under most practical conditions, gases are rather poor conductors of heat, so the energy transport by conduction may be neglected.<sup>1</sup> Henceforth, we will therefore assume that (1.47) is well approximated by

$$\rho c_v \frac{DT}{Dt} = -p \nabla \cdot \mathbf{u} + \rho q. \quad (1.48)$$

## 1.8 The equation of state

We have now succeeded in obtaining the energy equation (1.48) to supplement our model, but at the expense of introducing a further unknown: the temperature  $T$ . We are therefore still one equation short. The final piece of information we need is an *equation of state*, relating the pressure, density and temperature. For a so-called perfect gas, this equation reads

$$p = \rho RT, \quad (1.49)$$

where  $R$  is called the *gas constant*.<sup>2</sup> If a fixed mass  $M$  of gas occupies a volume  $V$ , then (1.49) reads

$$pV = MRT. \quad (1.50)$$

Thus, if the temperature is fixed, then  $pV$  is constant, which is known as *Boyle's Law*. On the other hand, if the pressure is fixed, then the gas expands as it heats, with the volume being proportional to  $T$ ; this is *Charles' Law*.

Now let us imagine heating up a mass  $M$  of gas under two different conditions, as shown schematically in figure 1.2. We start with the gas at temperature  $T_0$ , occupying a volume  $V_0$ , subject to an ambient pressure  $p_0$ . According to (1.50) these are related by  $p_0 V_0 = MRT_0$ , and recall that the internal energy associated with such a scenario is  $E_0 = M c_v T_0$ . If the volume is kept fixed, as depicted in figure 1.2(a), then the temperature may be raised by an amount  $\Delta T$  by supplying a thermal energy

$$\Delta E_v = M c_v \Delta T. \quad (1.51)$$

---

<sup>1</sup>This approximation may be made more rigorous by *nondimensionalising* the equations and identifying a *dimensionless parameter* that measures the importance of conduction. Here the relevant parameter is the *Péclet number*  $Pe = \rho c_v U L / k$ , where  $U$  and  $L$  are typical magnitudes of  $\mathbf{u}$  and  $\mathbf{x}$  respectively. If  $Pe$  is large, which is true for gases under most conditions of practical interest, then thermal conductivity is negligible. It is also worth noting that, in gases, the Péclet and Reynolds numbers are roughly equal, so neglecting thermal conductivity is consistent with neglecting viscosity.

<sup>2</sup>If  $M_u$  is the *molar mass* of the gas (*i.e.* the mass of one mole), then  $R = R^* / M_u$ , where  $R^* \approx 8.3143510 \text{ J mol}^{-1} \text{ K}^{-1}$  is the *universal gas constant*.

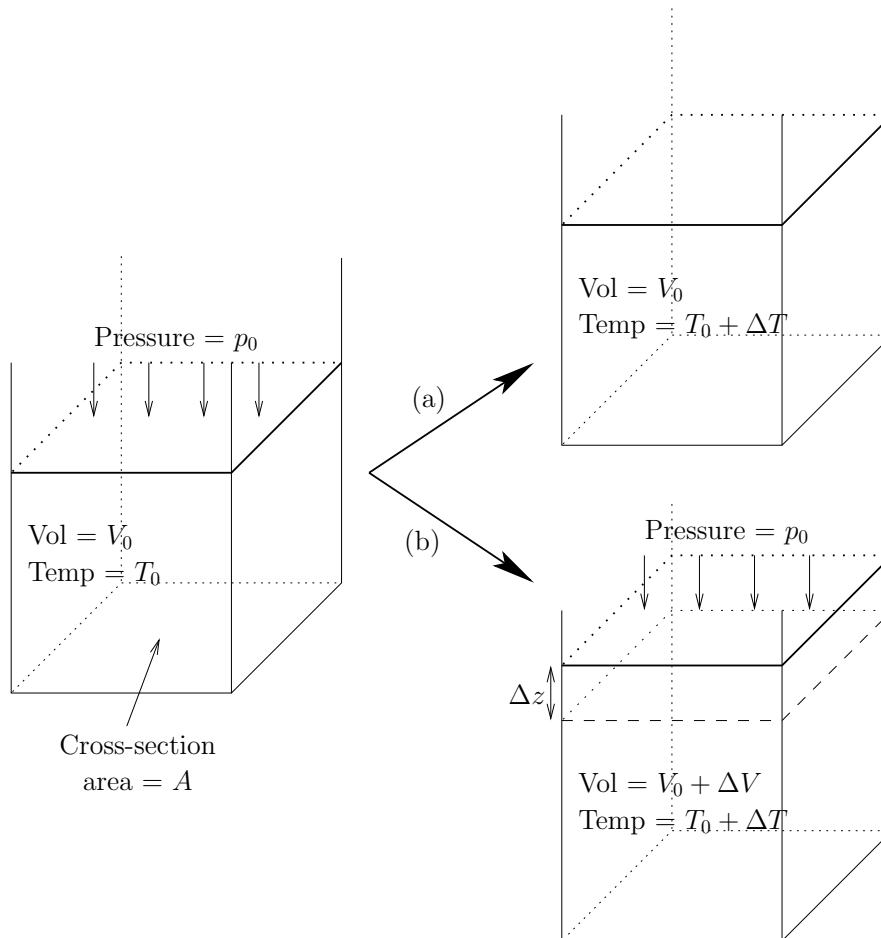

Figure 1.2: Schematic of a mass of gas heating up under (a) constant volume, (b) constant pressure.

If instead we raise the temperature by  $\Delta T$  while keeping the pressure  $p_0$  constant then, as indicated in figure 1.2(b), the gas will expand by an amount  $\Delta V$ , which may be found from (1.50):

$$p_0 \Delta V = MR \Delta T. \quad (1.52)$$

The final thermal energy contained in the gas is still given by  $E = E_0 + Mc_v \Delta T$  but now the gas, by expanding, has done some work to the external atmosphere. In the setup shown in figure 1.2(b), the gas occupies a cylindrical container, on the lid of which it exerts a force  $p_0 A$ , where  $A$  is the cross-sectional area. The work done when the lid rises by a distance  $\Delta z$  is therefore  $p_0 A \Delta z$ , that is

$$\text{work done} = p_0 \Delta V. \quad (1.53)$$

It is easy to show that the work done by a gas at constant pressure  $p_0$  expanding by a volume  $\Delta V$  is always given by (1.53), not just for the simple geometry shown in figure 1.2(b).

The net energy that must be supplied to effect this temperature change and expansion is thus given by

$$\Delta E_p = Mc_v \Delta T + p_0 \Delta V, \quad (1.54)$$

where the subscript  $p$  indicates that the temperature change occurs at constant pressure rather than constant volume. By using (1.52) we can write this as

$$\Delta E_p = Mc_p \Delta T, \quad (1.55)$$

where  $c_p$  is the *specific heat at constant pressure* (as opposed to the *specific heat at constant volume*  $c_v$ ), given by

$$c_p = R + c_v. \quad (1.56)$$

## 1.9 Entropy

Using (1.23) and (1.49), we can write the energy equation (1.48) in the form

$$\rho q = \rho c_v \frac{DT}{Dt} - \frac{p}{\rho} \frac{D\rho}{Dt} = \left(\frac{c_v}{R}\right) \rho \frac{D}{Dt} \left(\frac{p}{\rho}\right) - \frac{p}{\rho} \frac{D\rho}{Dt}. \quad (1.57)$$

If we define the *ratio of specific heats*

$$\gamma = \frac{c_p}{c_v} = 1 + \frac{R}{c_v}, \quad (1.58)$$

then (1.57) becomes

$$\rho q = \frac{1}{\gamma - 1} \left( \frac{Dp}{Dt} - \frac{\gamma p}{\rho} \frac{D\rho}{Dt} \right) = \frac{\rho^\gamma}{\gamma - 1} \frac{D}{Dt} \left( \frac{p}{\rho^\gamma} \right) \quad (1.59)$$

$$= \frac{p}{\gamma - 1} \frac{D}{Dt} \left\{ \log \left( \frac{p}{\rho^\gamma} \right) \right\}. \quad (1.60)$$

By using the equation of state (1.49) once more, we thus obtain

$$q = T \frac{DS}{Dt}, \quad (1.61)$$

where

$$S = S_0 + c_v \log \left( \frac{p}{\rho^\gamma} \right), \quad (1.62)$$

and  $S_0$  is a constant.

The function  $S$  is called the *entropy* of the fluid per unit mass. Since internal radiative cooling, as opposed to heating, is thought to be physically impossible,  $q$  must be non-negative and (1.61) then shows that the entropy is a non-decreasing function of time. This is an example of the so-called *Second Law of Thermodynamics*. If, as is usually the case, there is no internal heating, then (1.61) reduces to

$$\frac{DS}{Dt} = 0, \quad (1.63)$$

which implies that the entropy of each material element of fluid is constant. Such a flow is called *isentropic*. This means that, if the entropy is spatially uniform initially, then it is so for all time, and the flow is then called *homentropic*.

In homentropic flow, we thus have a simple functional relation

$$p = C\rho^\gamma \quad (1.64)$$

between  $p$  and  $\rho$ , where  $C$  is constant. The exponent  $\gamma$  is a constant greater than 1; for example  $\gamma \approx 1.4$  in air. By combining (1.64) with the mass- and momentum-conservation equations (1.23) and (1.27) we finally have a closed system of equations for  $\rho$ ,  $\mathbf{u}$  and  $p$ .

## 1.10 Boundary conditions

If the fluid is in contact with a fixed rigid boundary  $B$ , then the normal velocity of the fluid there must be zero, that is

$$\mathbf{u} \cdot \mathbf{n} = 0 \quad \text{on } B, \quad (1.65)$$

where  $\mathbf{n}$  denotes the unit normal to  $B$ . This condition states that the fluid can neither flow through  $B$  nor separate from  $B$ , leaving behind a vacuum.<sup>3</sup>

Next consider a *moving* boundary  $B(t)$ , for example a piston or a moving membrane. The condition corresponding to (1.65) is that the velocity of the fluid normal to  $B$  must equal the velocity of  $B$  normal to itself, that is

$$\mathbf{u} \cdot \mathbf{n} = \mathbf{v}_B \cdot \mathbf{n}, \quad (1.66)$$

---

<sup>3</sup>Notice the contrast with a *viscous* fluid, in which *all* the velocity components are zero on a fixed boundary:  $\mathbf{u} = \mathbf{0}$  on  $B$ . While a viscous fluid “sticks” to  $B$ , an inviscid fluid may slide past.

where  $\mathbf{v}_B$  is the velocity of  $B$ . At each instant  $t$  of time,  $B$  is a surface whose equation may be written implicitly as

$$f(\mathbf{x}, t) = 0 \quad (1.67)$$

for some function  $f$ . By writing  $\mathbf{n}$  in terms of  $f$ , (1.66) may be written as

$$\mathbf{u} \cdot \nabla f = \mathbf{v}_B \cdot \nabla f. \quad (1.68)$$

Now, any point  $\mathbf{x} = \mathbf{x}_B(t)$  that is fixed to the boundary  $B(t)$  must satisfy

$$\frac{d\mathbf{x}_B}{dt} = \mathbf{v}_B \quad \text{and} \quad f(\mathbf{x}_B(t), t) \equiv 0. \quad (1.69)$$

By differentiating the latter equation with respect to  $t$ , we obtain

$$\frac{\partial f}{\partial t} + \mathbf{v}_B \cdot \nabla f = 0. \quad (1.70)$$

Hence (1.68) implies that

$$\frac{\partial f}{\partial t} + \mathbf{u} \cdot \nabla f = \frac{Df}{Dt} = 0 \quad \text{when} \quad f = 0. \quad (1.71)$$

This so-called *kinematic boundary condition* implies that, if any fluid element starts at  $f = 0$ , then  $f$  remains at zero for that particular element. In other words, *any fluid element that starts on  $B(t)$  must stay there.*

If the boundary  $B$  is prescribed, whether it be fixed or moving, then just one boundary condition is needed, and either (1.65), (1.66) or (1.71) will suffice. One more condition is needed at a *free boundary*, whose position is unknown in advance. The simplest example is the interface between two impermeable fluids, for example water and air. If surface tension is neglected, then *the pressure must be continuous* across such an interface. Otherwise the interface would experience a finite force, which is impossible since it has zero mass.

## 1.11 Rotating fluids

To describe the flow in the Earth's atmosphere or oceans, it makes sense to express the equations of motion relative to axes that rotate with the Earth instead of "inertial" axes fixed in space. However, the governing equations we have derived so far apply only in an inertial frame. We must determine how the equations transform when we switch to a rotating frame.

Let  $S$  be an inertial frame, and  $R$  a rotating frame, rotating with angular velocity  $\boldsymbol{\Omega}$  with respect to  $S$ . Let  $(\hat{\mathbf{e}}_1, \hat{\mathbf{e}}_2, \hat{\mathbf{e}}_3)$  be a basis fixed in the rotating frame  $R$ . Then the motion of each  $\hat{\mathbf{e}}_i$  as viewed in  $S$  is given by

$$\left( \frac{d\hat{\mathbf{e}}_i}{dt} \right)_S = \boldsymbol{\Omega} \times \hat{\mathbf{e}}_i. \quad (1.72)$$

We can express any vector  $\mathbf{v}$  in terms of its components with respect to the basis  $\{\hat{\mathbf{e}}_i\}$  by writing  $\mathbf{v} = v_i \hat{\mathbf{e}}_i$  (where we have adopted the summation convention). Then

$$\left(\frac{d\mathbf{v}}{dt}\right)_S = \frac{dv_i}{dt} \hat{\mathbf{e}}_i + v_i (\boldsymbol{\Omega} \times \hat{\mathbf{e}}_i) \quad (1.73)$$

The first term on the right-hand side can be interpreted as the time derivative of  $\mathbf{v}$  in the rotating frame  $R$ , since it is obtained by differentiating each component in the basis fixed in  $R$ . Hence we obtain

$$\left(\frac{d\mathbf{v}}{dt}\right)_S = \left(\frac{d\mathbf{v}}{dt}\right)_R + \boldsymbol{\Omega} \times \mathbf{v}, \quad (1.74)$$

which holds for any vector  $\mathbf{v}$ .

By setting  $\mathbf{v} = \mathbf{x}(t)$  the position of a fluid element, we obtain

$$\left(\frac{d\mathbf{x}}{dt}\right)_S = \left(\frac{d\mathbf{x}}{dt}\right)_R + \boldsymbol{\Omega} \times \mathbf{x}. \quad (1.75)$$

Then, by applying (1.74) again with  $\mathbf{v} = (d\mathbf{x}/dt)_S$ , we get

$$\begin{aligned} \left(\frac{d^2\mathbf{x}}{dt^2}\right)_S &= \frac{d}{dt} \left( \left(\frac{d\mathbf{x}}{dt}\right)_R + \boldsymbol{\Omega} \times \mathbf{x} \right) + \boldsymbol{\Omega} \times \left( \left(\frac{d\mathbf{x}}{dt}\right)_R + \boldsymbol{\Omega} \times \mathbf{x} \right), \\ &= \left(\frac{d^2\mathbf{x}}{dt^2}\right)_R + 2\boldsymbol{\Omega} \times \left(\frac{d\mathbf{x}}{dt}\right)_R + \left(\frac{d\boldsymbol{\Omega}}{dt}\right)_R \times \mathbf{x} + \boldsymbol{\Omega} \times (\boldsymbol{\Omega} \times \mathbf{x}). \end{aligned} \quad (1.76)$$

We now note that

$$\left(\frac{d\mathbf{x}}{dt}\right)_S = \mathbf{u}_S, \quad \left(\frac{d^2\mathbf{x}}{dt^2}\right)_S = \left(\frac{D\mathbf{u}_S}{Dt}\right)_S, \quad (1.77)$$

where  $\mathbf{u}_S$  is the fluid velocity as seen in the inertial frame  $S$ . Similarly we have

$$\left(\frac{d\mathbf{x}}{dt}\right)_R = \mathbf{u}_R, \quad \left(\frac{d^2\mathbf{x}}{dt^2}\right)_R = \left(\frac{D\mathbf{u}_R}{Dt}\right)_R. \quad (1.78)$$

With  $\boldsymbol{\Omega}$  taken to be constant, the two results (1.75) and (1.76) therefore become

$$\mathbf{u}_S = \mathbf{u}_R + \boldsymbol{\Omega} \times \mathbf{x}, \quad \left(\frac{D\mathbf{u}_S}{Dt}\right)_S = \left(\frac{D\mathbf{u}_R}{Dt}\right)_R + 2\boldsymbol{\Omega} \times \mathbf{u}_R + \boldsymbol{\Omega} \times (\boldsymbol{\Omega} \times \mathbf{x}). \quad (1.79)$$

The change of frame from  $S$  to  $R$  affects only the time derivatives of vectors, so mass- and energy-conservation equations (1.23) and (1.48) are unchanged when we move the rotating frame. Using the result (1.79), and dropping the subscript  $R$ s, the momentum equation (1.27) becomes

$$\frac{D\mathbf{u}}{Dt} + 2\boldsymbol{\Omega} \times \mathbf{u} + \boldsymbol{\Omega} \times (\boldsymbol{\Omega} \times \mathbf{x}) = -\frac{1}{\rho} \nabla p + \mathbf{g} \quad (1.80)$$

in the rotating frame  $R$ .



## 2 Models for linear wave propagation

### 2.1 Introduction

In this section we derive several different models for the propagation of waves in fluids. In each case, we assume the amplitude is sufficiently small for the equations to be linearised. Our first example is *acoustic waves* in a gas, which are governed by the wave equation and therefore move at a well-defined constant wave-speed. In contrast, gravity waves on the surface of a layer of fluid are *dispersive*, meaning that waves with different wavelengths move at different speeds. We also derive models for *internal gravity waves* in a stratified fluid and *inertial waves* in a rotating fluid.

### 2.2 Acoustic waves in a gas

#### The wave equation

Here we consider so-called *barotropic* flow, in which the pressure is a given function of the density, say

$$p = P(\rho). \quad (2.1a)$$

We have shown, for example, that an ideal gas with uniform entropy satisfies (2.1a), with  $P(\rho) = C\rho^\gamma$ , but for the moment we will study the more general case (2.1a). The equations for conservation of mass and momentum, namely

$$\frac{\partial \rho}{\partial t} + \nabla \cdot (\rho \mathbf{u}) = 0, \quad (2.1b)$$

$$\rho \left( \frac{\partial \mathbf{u}}{\partial t} + (\mathbf{u} \cdot \nabla) \mathbf{u} \right) = -\nabla p + \rho \mathbf{g}, \quad (2.1c)$$

combined with (2.1a), provide a closed system for  $\rho$ ,  $\mathbf{u}$  and  $p$ . For the moment, we will assume that the body force  $\mathbf{g}$  is negligible.

The system (2.1) is nonlinear and hence very difficult to solve in general. We therefore try to simplify the equations, by considering small disturbances about an assumed uniform initial state. Suppose the fluid starts at rest with constant density  $\rho_0$  and pressure  $p_0 = P(\rho_0)$ . We perturb about these initial conditions by setting

$$\rho = \rho_0 + \rho', \quad \mathbf{u} = \mathbf{0} + \mathbf{u}', \quad p = p_0 + p', \quad (2.2)$$

in which the primed variables are assumed to be small.<sup>1</sup> If we apply Taylor's Theorem to (2.1a) and neglect products of primed variables, we obtain

$$p' = c_0^2 \rho', \quad (2.3)$$

where the positive constant  $c_0$  is defined by

$$c_0^2 = \frac{dP}{d\rho}(\rho_0). \quad (2.4)$$

In a homentropic ideal gas, for example, we have  $c_0^2 = \gamma p_0 / \rho_0$ .

Linearisation of the momentum equation (2.1c) leads to

$$\rho_0 \frac{\partial \mathbf{u}'}{\partial t} = -\nabla p' = -c_0^2 \nabla \rho' \quad (2.5)$$

and, by taking the curl of this equation, we obtain

$$\frac{\partial}{\partial t} (\nabla \times \mathbf{u}') = \mathbf{0}. \quad (2.6)$$

Hence, if  $\nabla \times \mathbf{u}' = \mathbf{0}$  initially (which is true if the fluid starts from rest) then it is zero for all time and we can write

$$\mathbf{u}' = \nabla \phi, \quad (2.7)$$

where  $\phi$  is the velocity potential. Substituting (2.7) back into (2.5), we obtain

$$\nabla \left( \rho_0 \frac{\partial \phi}{\partial t} + c_0^2 \rho' \right) = \mathbf{0} \quad (2.8)$$

and it follows that

$$\rho_0 \frac{\partial \phi}{\partial t} + c_0^2 \rho' = F(t) \quad (2.9)$$

where  $F$  is an arbitrary scalar function. Since an arbitrary function of  $t$  may be added to  $\phi$  without affecting (2.7), we may set  $F(t) \equiv 0$  without loss of generality and thus obtain

$$\rho_0 \frac{\partial \phi}{\partial t} + c_0^2 \rho' = 0. \quad (2.10)$$

This is the linearised version of *Bernoulli's equation*.

Linearisation of (2.1b) gives

$$\frac{\partial \rho'}{\partial t} + \rho_0 \nabla^2 \phi = 0 \quad (2.11)$$

and, by eliminating  $\rho'$  between (2.10) and (2.11), we find that  $\phi$  satisfies the *wave equation*:

$$\frac{\partial^2 \phi}{\partial t^2} = c_0^2 \nabla^2 \phi. \quad (2.12a)$$

From (2.3) and (2.10), it is clear that  $\rho'$  and  $p'$  also satisfy exactly the same partial differential equation, that is

$$\frac{\partial^2 \rho'}{\partial t^2} = c_0^2 \nabla^2 \rho', \quad \frac{\partial^2 p'}{\partial t^2} = c_0^2 \nabla^2 p'. \quad (2.12b)$$

---

<sup>1</sup>Exactly what we mean by "small" here may be quantified by nondimensionalising the equations and identifying an appropriate small dimensionless parameter.

### One-dimensional waves

If  $p$  is a function only of one spatial variable  $x$  and time  $t$ , then (2.12a) reads

$$\frac{\partial^2 p'}{\partial t^2} = c_0^2 \frac{\partial^2 p'}{\partial x^2}. \quad (2.13)$$

It is straightforward to show that the *general solution* of (2.13) is

$$p' = F(x - c_0 t) + G(x + c_0 t), \quad (2.14)$$

where  $F$  and  $G$  are arbitrary scalar functions. These represent waves, with initial shapes given by  $F(x)$  and  $G(x)$ , moving at speed  $c_0$  from left to right and from right to left respectively. These are *sound waves*, and  $c_0$  is the *speed of sound* in the undisturbed fluid.

Suppose, for example, that a transducer at  $x = 0$  imposes a periodic pressure fluctuation with frequency  $\omega$ , that is

$$p'(0, t) = a \cos(\omega t) + b \sin(\omega t), \quad (2.15)$$

for some constants  $a$  and  $b$ . It is convenient to write (2.15) in the form

$$p'(0, t) = \operatorname{Re} \{ A e^{-i\omega t} \}, \quad (2.16)$$

where  $A = a + ib$  is the *complex amplitude*. We can then seek a solution of (2.13) in the form

$$p'(x, t) = \operatorname{Re} \{ f(x) e^{-i\omega t} \}, \quad (2.17)$$

for some (complex-valued) function  $f(x)$ . In fact, because taking the real part commutes with differentiation, we can ignore the “Re” for the moment and then simply take the real part at the end of the calculation. Note that this approach only works for *linear* problems.

Substitution for  $p'$  from (2.17) into (2.13) and (2.16) leads to the problem

$$\frac{d^2 f}{dx^2} + \frac{\omega^2}{c_0^2} f = 0, \quad f(0) = A. \quad (2.18)$$

The general solution of (2.18) is

$$f(x) = \alpha e^{i\omega x/c_0} + \beta e^{-i\omega x/c_0}, \quad \text{where } \alpha + \beta = A. \quad (2.19)$$

Evidently one more piece of information is needed to determine the two constants  $\alpha$  and  $\beta$ . We impose a *radiation condition*, namely that the source at  $x = 0$  can only cause *outward-travelling* waves. In  $x > 0$ , we therefore want waves travelling to the right, with  $p'$  a function of  $x - c_0 t$ . This implies that  $\beta$  must be zero, and an analogous argument shows that  $\alpha$  must be zero in  $x < 0$ . We therefore obtain

$$f(x) = \begin{cases} A e^{i\omega x/c_0} & x > 0, \\ A e^{-i\omega x/c_0} & x < 0, \end{cases} \quad (2.20)$$

and by substituting this into (2.17) we find the solution

$$p'(x, t) = \begin{cases} \operatorname{Re} \left\{ A e^{-i\omega(t-x/c_0)} \right\} & x > 0, \\ \operatorname{Re} \left\{ A e^{-i\omega(t+x/c_0)} \right\} & x < 0. \end{cases} \quad (2.21)$$

### Waves due to a point source

If  $p'$  is a function only of distance from the origin,  $r = \sqrt{x^2 + y^2 + z^2}$ , and time  $t$ , then (2.12b) reads

$$\frac{\partial^2 p'}{\partial t^2} = c_0^2 \nabla^2 p' = c_0^2 \left( \frac{\partial^2 p'}{\partial r^2} + \frac{2}{r} \frac{\partial p'}{\partial r} \right) = \frac{c_0^2}{r} \frac{\partial^2}{\partial r^2} (r p'). \quad (2.22)$$

It follows that  $(r p')$  satisfies the usual wave equation in  $r$  and  $t$  and, hence, that the general solution is

$$p' = \frac{F(r - c_0 t)}{r} + \frac{G(r + c_0 t)}{r}. \quad (2.23)$$

Notice that these radial waves are generally unbounded at the origin, with  $p' \sim 1/r$  as  $r \rightarrow 0$ .

Let us again try to find the wave-field generated by a point transducer at the origin. In the light of (2.23), we suppose that the pressure behaves like

$$r p'(r, t) \rightarrow A e^{-i\omega t} \quad \text{as } r \rightarrow 0, \quad (2.24)$$

where the real part is assumed. Seeking a separable solution of the form

$$p'(r, t) = f(r) e^{-i\omega t}, \quad (2.25)$$

we find that  $f(r)$  satisfies

$$\frac{d^2}{dr^2} (r f) + \frac{\omega^2}{c_0^2} (r f) = 0, \quad r f(r) \rightarrow A \text{ as } r \rightarrow 0. \quad (2.26)$$

To get a unique solution, we must again impose a radiation condition, namely that  $p'$  should be a function of  $r - c_0 t$  rather than  $r + c_0 t$ . The appropriate solution of (2.26) is

$$f(r) = \frac{A e^{i\omega r/c_0}}{r} \quad (2.27)$$

and hence the pressure perturbation is

$$p'(r, t) = \frac{\operatorname{Re} \left\{ A e^{-i\omega(t-r/c_0)} \right\}}{r}. \quad (2.28)$$

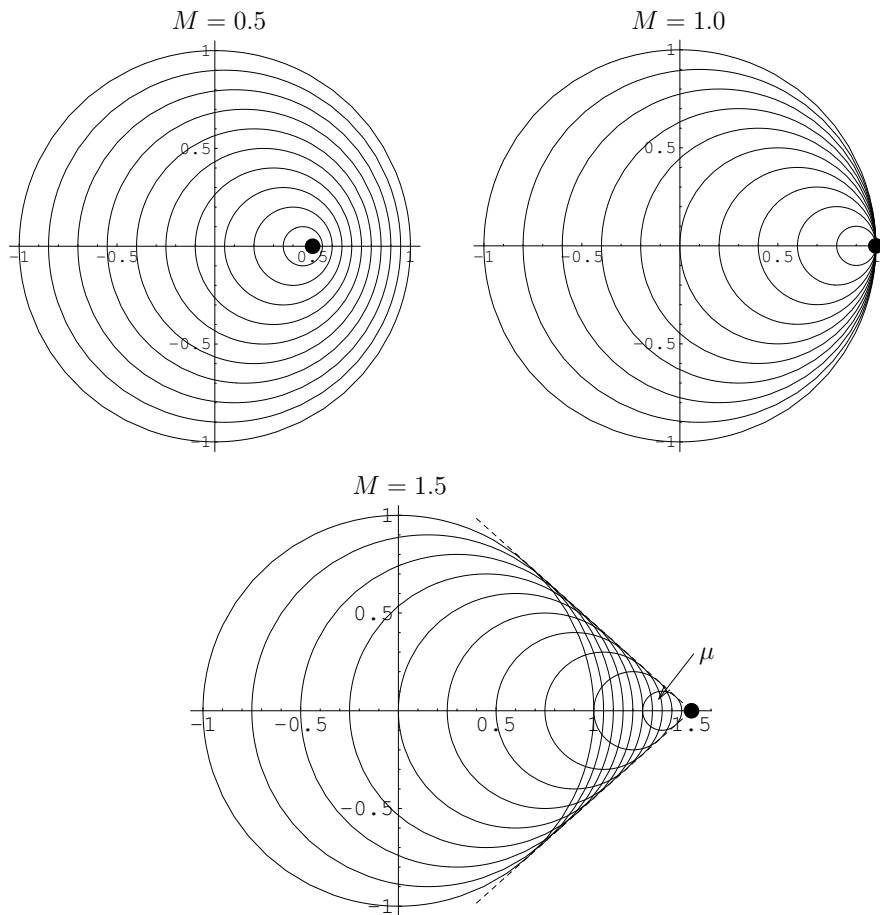

Figure 2.1: A source moving with Mach number  $M = 0.5, 1.0, 1.5$ . In the final case, the angle of the cone is the *Mach angle*  $\mu$ .

### Waves due to a moving source

Now suppose the source is moving with speed  $U$ , while emitting waves that propagate at speed  $c_0$ . The qualitative behaviour depends crucially on the Mach number

$$M = \frac{U}{c_0}. \quad (2.29)$$

If  $M < 1$  then source travels slower than the speed of sound, and is referred to as *subsonic*. The sound waves propagate ahead of the source, as illustrated in figure 2.1 (when  $M = 0.5$ ). The waves in front of the source are compressed while those behind are stretched, so a fixed observer would hear the pitch of the sound decrease as the source travels past; this is the celebrated *Doppler effect*.

If  $M = 1$  (so the flow is *sonic*) then the source travels at exactly the same speed as the sound that it is emitting. Thus, as illustrated in figure 2.1, it can never escape from its own noise. Finally, if  $M > 1$ , then the source outstrips the sound waves, and is

called *supersonic*. The noise is confined to a cone, as shown in figure 2.1 with  $M = 1.5$ . Outside the cone is a *zone of silence*, and a stationary observer would hear nothing until the cone reaches him or her. The vertex of the cone makes an angle known as the *Mach angle*  $\mu$ , and it is a simple exercise in trigonometry to show that

$$\sin \mu = \frac{1}{M}. \quad (2.30)$$

To describe such effects mathematically, it is easiest to work in a frame with the source fixed (say at the origin) and the fluid flows past at uniform speed  $U$ . Hence we put

$$\rho = \rho_0 + \rho', \quad \mathbf{u} = U\hat{\mathbf{e}}_x + \mathbf{u}', \quad p = p_0 + p', \quad (2.31)$$

into (2.1) and again linearise with respect to the primed variables, resulting in

$$\frac{\partial \rho'}{\partial t} + U \frac{\partial \rho'}{\partial x} + \rho_0 \nabla \cdot \mathbf{u} = 0, \quad \rho_0 \left( \frac{\partial \mathbf{u}'}{\partial t} + U \frac{\partial \mathbf{u}'}{\partial x} \right) = -\nabla p', \quad p' = c_0^2 \rho'. \quad (2.32)$$

Again, it is straightforward to show that the flow is irrotational for all time if it is so initially, so we can introduce a velocity potential  $\phi$  such that  $\mathbf{u}' = \nabla \phi$ .

Now, if an arbitrary function of  $t$  is absorbed into  $\phi$  as before, we find that  $\phi$  and  $\rho'$  satisfy the coupled equations

$$\rho_0 \left( \frac{\partial \phi}{\partial t} + U \frac{\partial \phi}{\partial x} \right) + c_0^2 \rho' = 0, \quad \frac{\partial \rho'}{\partial t} + U \frac{\partial \rho'}{\partial x} + \rho_0 \nabla^2 \phi = 0. \quad (2.33)$$

By eliminating between these, we can obtain a single partial differential equation for either  $\phi$ ,  $\rho'$  or  $p'$ , namely

$$\frac{\partial^2 \phi}{\partial t^2} + 2U \frac{\partial^2 \phi}{\partial x \partial t} + U^2 \frac{\partial^2 \phi}{\partial x^2} = c_0^2 \nabla^2 \phi, \quad (2.34a)$$

$$\frac{\partial^2 \rho'}{\partial t^2} + 2U \frac{\partial^2 \rho'}{\partial x \partial t} + U^2 \frac{\partial^2 \rho'}{\partial x^2} = c_0^2 \nabla^2 \rho', \quad \frac{\partial^2 p'}{\partial t^2} + 2U \frac{\partial^2 p'}{\partial x \partial t} + U^2 \frac{\partial^2 p'}{\partial x^2} = c_0^2 \nabla^2 p'. \quad (2.34b)$$

To understand the implications of these equations, let us consider some special cases. First, for sound propagating in just one space dimension, say  $p' = p'(x, t)$ , (2.34b) becomes

$$\frac{\partial^2 p'}{\partial t^2} + 2U \frac{\partial^2 p'}{\partial x \partial t} + (U^2 - c_0^2) \frac{\partial^2 p'}{\partial x^2} = 0. \quad (2.35)$$

It is readily verified that this partial differential equation is *hyperbolic*, with characteristics given by

$$\frac{dx}{dt} = U \pm c_0. \quad (2.36)$$

For subsonic flow,  $U < c_0$  and the characteristic velocities (2.36) take different signs, indicating that waves travel in both directions. For supersonic flow,  $U > c_0$  so the

characteristic velocities are both positive. This means that waves can only propagate downstream in this case, and there is a zone of silence upstream of the source.

Next, we try looking for two-dimensional steady solutions, setting  $p' = p'(x, y)$ , so (2.34b) becomes

$$(1 - M^2) \frac{\partial^2 p'}{\partial x^2} + \frac{\partial^2 p'}{\partial y^2} = 0, \quad (2.37)$$

where  $M = U/c_0$  is the Mach number as before. For  $M < 1$ , (2.37) is *elliptic*, and is qualitatively similar to Laplace's equation. For  $M > 1$ , though, (2.37) is *hyperbolic*, and is analogous to the wave equation; indeed, the general solution of (2.37) in this case is readily found to be

$$p' = f\left(y - \frac{x}{\sqrt{M^2 - 1}}\right) + g\left(y + \frac{x}{\sqrt{M^2 - 1}}\right), \quad (2.38)$$

where  $f$  and  $g$  are two arbitrary scalar functions

The *change of type* of the partial differential equation (2.37) as the Mach number passes through 1 is associated with a dramatic change in the character of the flow. In subsonic flow, the elliptic equation causes localised effects to be felt everywhere instantaneously. In supersonic flow, however, disturbances can only propagate along the *characteristics*, given by

$$\frac{dy}{dx} = \pm \frac{1}{\sqrt{M^2 - 1}} = \pm \tan \mu, \quad (2.39)$$

where  $\mu = \sin^{-1}(1/M)$  is the Mach angle as before. This explains the differences depicted in figure 2.1. In the subsonic flow, waves from the source penetrate the whole space while, in supersonic flow, they are only felt in the Mach cone downstream of the source.

## 2.3 Stokes waves on a free surface

### Equations and boundary conditions

*Stokes waves* are small-amplitude gravity waves on the surface of an incompressible fluid, for example small ripples on a container of water. As shown in section 1, we may assume that the flow is irrotational, if it is so initially. We therefore introduce a velocity potential  $\phi$ , such that  $\mathbf{u} = \nabla\phi$  and  $\phi$  satisfies Laplace's equation:

$$\nabla^2 \phi = 0. \quad (2.40)$$

We also recall from section 1 Bernoulli's equation,

$$\frac{\partial \phi}{\partial t} + \frac{1}{2} |\nabla \phi|^2 + \frac{p}{\rho} + \chi = F(t), \quad (2.41)$$

where  $\chi$  is the gravitational potential and  $F(t)$  may be chosen arbitrarily.

We consider a layer of fluid of depth  $h$ , between a rigid base at  $z = -h$  and a free surface that is initially at  $z = 0$ , where the  $z$ -axis points vertically upwards.

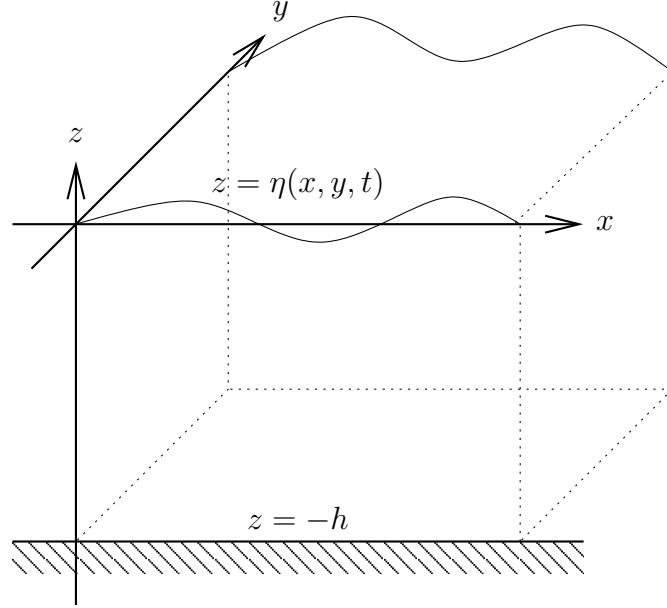

Figure 2.2: Definition sketch of the geometry for Stokes waves on a fluid layer of depth  $h$ .

Small-amplitude waves then perturb the fluid such that the free surface is displaced to  $z = \eta(x, y, t)$ , as illustrated in figure 2.2.

On the base  $z = -h$ , the normal velocity  $w$  must be zero, that is

$$\frac{\partial \phi}{\partial z} = 0 \quad \text{at } z = -h. \quad (2.42)$$

On the free surface  $z = \eta$  we have the kinematic boundary condition

$$\frac{D}{Dt} (z - \eta) = 0 \quad (2.43)$$

which, when written out in terms of  $\phi$ , reads

$$\frac{\partial \phi}{\partial z} = \frac{\partial \eta}{\partial t} + \frac{\partial \phi}{\partial x} \frac{\partial \eta}{\partial x} + \frac{\partial \phi}{\partial y} \frac{\partial \eta}{\partial y} \quad \text{at } z = \eta(x, y, t). \quad (2.44)$$

We also have the *dynamic boundary condition* that the pressure must be continuous across the interface, that is

$$p = p_a \quad \text{at } z = \eta(x, y, t), \quad (2.45)$$

where  $p_a$  is the atmospheric pressure, assumed constant.

We can use Bernoulli's equation (2.41) to turn (2.45) into a boundary condition for  $\phi$ . With the  $z$ -axis pointing upwards, the gravitational potential is  $\chi = gz$ . We can also choose  $F(t) = p_a/\rho$  to eliminate the constant pressure and thus end up with

$$\frac{\partial \phi}{\partial t} + \frac{1}{2} |\nabla \phi|^2 + g\eta = 0 \quad \text{at } z = \eta(x, y, t). \quad (2.46)$$



The problem, then, is to solve (2.40) for  $\phi$ , subject to the boundary conditions (2.42), (2.44) and (2.46). Notice that one more condition is needed at the free surface than at the base, since the displacement  $\eta(x, y, t)$  is also unknown in advance.

Although Laplace's equation is linear, the boundary conditions (2.44) and (2.46) on the free surface are nonlinear, and the problem is therefore difficult to solve in general. If the disturbances are small, then the boundary conditions can be simplified by linearising, that is neglecting products of terms involving  $\eta$  and  $\phi$ . For example, if we neglect the quadratic terms in (2.44), we find

$$\frac{\partial\phi}{\partial z} = \frac{\partial\eta}{\partial t} \quad \text{at } z = \eta(x, y, t). \quad (2.47)$$

This can be simplified further by Taylor-expanding the left-hand side as follows:

$$\frac{\partial\phi}{\partial z}(x, y, \eta, t) \sim \frac{\partial\phi}{\partial z}(x, y, 0, t) + \frac{\partial^2\phi}{\partial z^2}(x, y, 0, t)\eta + \dots, \quad (2.48)$$

in which all terms except the first are nonlinear. When linearising the boundary conditions, it is thus consistent also to evaluate the left-hand side of (2.47) at  $z = 0$  rather than  $z = \eta$ . The same simplification applies when we linearise (2.46), so we end up with the boundary conditions

$$\frac{\partial\phi}{\partial z} = \frac{\partial\eta}{\partial t}, \quad \frac{\partial\phi}{\partial t} + g\eta = 0 \quad \text{at } z = 0. \quad (2.49)$$

### One-dimensional waves

Now we look for solutions in which  $\eta$  is of the form

$$\eta(x, t) = Ae^{i(kx - \omega t)}, \quad (2.50)$$

where  $A$  is a constant and the real part is assumed. (Because the problem is linear, we can proceed with the complex solution (2.50) and then take the real part at the end.) The parameter  $\omega$  represents the *frequency* at which the surface oscillates at any fixed position  $x$ . The *wavenumber*  $k$  is  $2\pi/\lambda$ , where  $\lambda$  is the wavelength; thus  $k$  is small for long waves and large for short waves. The *phase velocity* at which the waves propagate is related to  $\omega$  and  $k$  by

$$c_p = \frac{\omega}{k}. \quad (2.51)$$

It is consistent with (2.50) to assume that  $\phi$  is of the form

$$\phi(x, z, t) = f(z)e^{i(kx - \omega t)}. \quad (2.52)$$

By substituting this into Laplace's equation (2.40), we find that  $f$  satisfies

$$\frac{d^2f}{dz^2} - k^2f = 0. \quad (2.53)$$

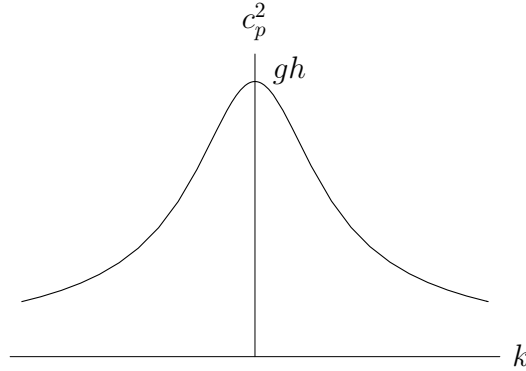

Figure 2.3: The squared wave-speed  $c_p^2$  given by (2.57) versus wavenumber  $k$ .

Clearly  $f$  is a linear combination of  $e^{kz}$  and  $e^{-kz}$ , and the correct combination to satisfy the boundary condition (2.42) on the base is

$$f = B \cosh(k(z + h)), \quad (2.54)$$

where  $B$  is an arbitrary constant.

By substituting (2.50) and (2.54) into the free-surface conditions (2.49), we obtain a linear system of equations for  $A$  and  $B$ , which may be written in the form

$$\begin{pmatrix} i\omega & k \sinh(kh) \\ g & -i\omega \cosh(kh) \end{pmatrix} \begin{pmatrix} A \\ B \end{pmatrix} = \mathbf{0}. \quad (2.55)$$

This homogeneous linear system admits the solution  $A = B = 0$ , corresponding to zero disturbance:  $\eta = \phi = 0$ . A nontrivial solution can only exist if the determinant of the left-hand side is zero, that is

$$\omega^2 = gk \tanh(kh). \quad (2.56)$$

This equation for the frequency in terms of the wavenumber is called the *dispersion relation*. From it we can infer the wave-speed

$$c_p^2 = \frac{g}{k} \tanh(kh), \quad (2.57)$$

which depends on the wavenumber  $k$ ; that is, waves with different wavenumbers move at different speeds. Such waves are called *dispersive*, in contrast with acoustic waves, which have a constant wave speed.

As depicted in figure 2.3, for positive  $k$ , the right-hand side of (2.57) is a decreasing function, indicating that long waves travel faster than short waves. The maximum wave speed occurs in the limit  $k \rightarrow 0$ , which yields

$$c_p \leq \sqrt{gh}. \quad (2.58)$$

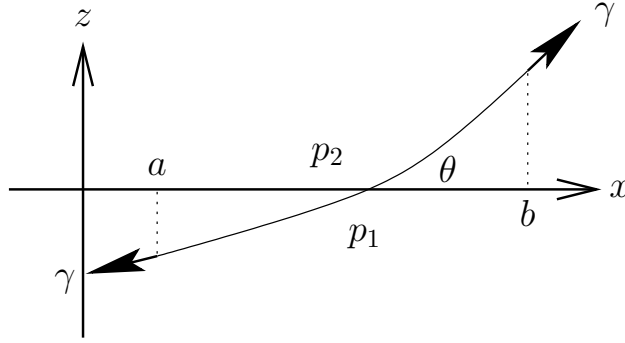

Figure 2.4: Schematic showing the surface tension  $\gamma$  acting at a fluid interface.

### Extensions

Here we briefly summarise a few common generalisations of Stokes waves.

**Flowing fluid** We can study waves on a flowing liquid by linearising about uniform flow, setting

$$\mathbf{u} = U\hat{\mathbf{e}}_x + \nabla\phi, \quad (2.59)$$

where  $\phi$  and its derivatives are again assumed to be small. It is clear that  $\phi$  still satisfies Laplace's equation, and the only effect is to modify the free-surface conditions to

$$\frac{\partial\phi}{\partial z} = \frac{\partial\eta}{\partial t} + U\frac{\partial\eta}{\partial x}, \quad \frac{\partial\phi}{\partial t} + U\frac{\partial\phi}{\partial x} + g\eta = 0 \quad \text{at } z = 0. \quad (2.60)$$

**Two fluids** Suppose the interface  $z = \eta$  separates two fluids with different densities, say  $\rho = \rho_1$  in  $z < 0$  and  $\rho = \rho_2$  in  $z > 0$ . We denote the velocity potentials and pressures on either side by  $\phi_1, \phi_2$  and  $p_1, p_2$  respectively. The kinematic condition (2.44) applies to both sides of the interface, and leads to the linearised boundary conditions

$$\frac{\partial\eta}{\partial t} = \frac{\partial\phi_1}{\partial z} = \frac{\partial\phi_2}{\partial z} \quad \text{at } z = 0. \quad (2.61)$$

The dynamic boundary condition (2.45) is replaced by the pressure continuity condition  $p_1 = p_2$  at  $z = \eta$ . After use of Bernoulli's equation and linearisation, this leads to the boundary condition

$$\rho_1 \left( \frac{\partial\phi_1}{\partial t} + g\eta \right) = \rho_2 \left( \frac{\partial\phi_2}{\partial t} + g\eta \right) \quad \text{at } z = 0. \quad (2.62)$$

Notice that (2.49) is recovered if we let the density ratio  $\rho_2/\rho_1$  tend to zero.

**Surface tension** Real fluid interfaces exhibit a phenomenon called *surface tension*, which acts like a membrane stretched over the interface to a tension  $\gamma$ . In figure 2.4 we show the forces acting on small two-dimensional element of the interface, namely the

pressures on either side and the surface tension at the ends. These forces must sum to zero, that is

$$\int_a^b (p_1 - p_2) \begin{pmatrix} -\sin \theta \\ \cos \theta \end{pmatrix} ds + \left[ \gamma \begin{pmatrix} \cos \theta \\ \sin \theta \end{pmatrix} \right]_a^b = \mathbf{0}, \quad (2.63)$$

where  $s$  is arc length and  $\theta$  is the angle made by the interface with the horizontal. Assuming  $\gamma$  is constant, we can rewrite this as

$$\int_a^b \left\{ (p_1 - p_2) \begin{pmatrix} -\sin \theta \\ \cos \theta \end{pmatrix} + \gamma \frac{d}{ds} \begin{pmatrix} \cos \theta \\ \sin \theta \end{pmatrix} \right\} ds = \mathbf{0}, \quad (2.64)$$

which holds for all  $a$  and  $b$ , so the integrand must be zero. Hence there is a pressure jump across the interface, given by

$$p_1 - p_2 = -\gamma\kappa, \quad (2.65)$$

where

$$\kappa = \frac{d\theta}{ds} = \left\{ 1 + \left( \frac{\partial \eta}{\partial x} \right)^2 \right\}^{-3/2} \frac{\partial^2 \eta}{\partial x^2} \quad (2.66)$$

is the *curvature* of the interface.<sup>2</sup> The latter equality can be obtained from the relations

$$\frac{\partial \eta}{\partial x} = \tan \theta, \quad \frac{dx}{ds} = \cos \theta. \quad (2.67)$$

After linearisation, the dynamic boundary condition is thus modified to

$$\rho_1 \left( \frac{\partial \phi_1}{\partial t} + g\eta \right) - \rho_2 \left( \frac{\partial \phi_2}{\partial t} + g\eta \right) = \gamma \frac{\partial^2 \eta}{\partial x^2} \quad \text{at } z = 0 \quad (2.68)$$

to take account of surface tension. Note that (2.62) is recovered if  $\gamma$  is set to zero.

### Example

We illustrate all these effects by analysing the situation shown in figure 2.5, where a layer of depth  $h_2$  and density  $\rho_2$  flows at speed  $U$  over a layer of depth  $h_1$  and density  $\rho_1$ . The disturbance potentials  $\phi_1$ ,  $\phi_2$  and the free-surface deflection  $\eta$  satisfy

$$\nabla^2 \phi_1 = 0 \quad -h_1 < z < 0, \quad \nabla^2 \phi_2 = 0 \quad 0 < z < h_2, \quad (2.69a)$$

$$\frac{\partial \phi_1}{\partial z} = 0 \quad z = -h_1, \quad \frac{\partial \phi_2}{\partial z} = 0 \quad z = h_2, \quad (2.69b)$$

<sup>2</sup>In three dimensions, (2.65) still holds, with  $\kappa$  equal to the *mean curvature* of the interface, that is

$$\kappa = \frac{\partial}{\partial x} \left\{ \frac{\partial \eta}{\partial x} / \sqrt{1 + \left( \frac{\partial \eta}{\partial x} \right)^2 + \left( \frac{\partial \eta}{\partial y} \right)^2} \right\} + \frac{\partial}{\partial y} \left\{ \frac{\partial \eta}{\partial y} / \sqrt{1 + \left( \frac{\partial \eta}{\partial x} \right)^2 + \left( \frac{\partial \eta}{\partial y} \right)^2} \right\}.$$

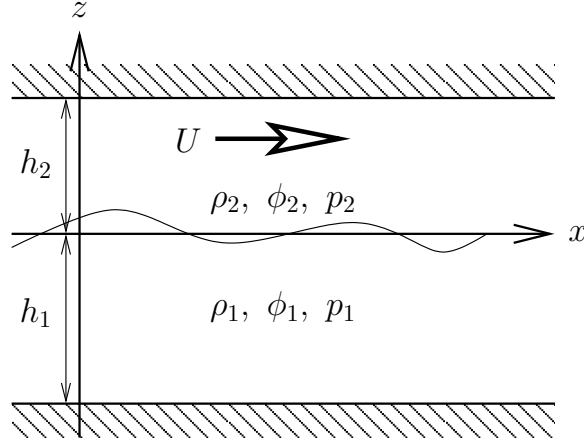

Figure 2.5: Schematic of a fluid layer of thickness  $h_2$  and density  $\rho_2$  flowing at speed  $U$  over a layer of thickness  $h_1$  and  $\rho_1$ .

$$\left. \begin{aligned} \frac{\partial \phi_1}{\partial z} &= \frac{\partial \eta}{\partial t}, & \frac{\partial \phi_2}{\partial z} &= \frac{\partial \eta}{\partial t} + U \frac{\partial \eta}{\partial x}, \\ \rho_1 \left( \frac{\partial \phi_1}{\partial t} + g\eta \right) - \rho_2 \left( \frac{\partial \phi_2}{\partial t} + U \frac{\partial \phi_2}{\partial x} + g\eta \right) &= \gamma \frac{\partial^2 \eta}{\partial x^2} \end{aligned} \right\} z = 0. \quad (2.69c)$$

We look for travelling waves of the form

$$\eta = Ae^{i(kx - \omega t)}, \quad \phi_1 = Be^{i(kx - \omega t)} \cosh(k(z + h_1)), \quad \phi_2 = Ce^{i(kx - \omega t)} \cosh(k(z - h_2)), \quad (2.70)$$

and find the dispersion relation

$$\omega^2 \rho_1 \coth(kh_1) + (\omega - Uk)^2 \rho_2 \coth(kh_2) = ((\rho_1 - \rho_2)g + \gamma k^2) k. \quad (2.71)$$

For simplicity, we take the limit where both layers are very deep, that is  $h_1, h_2 \rightarrow \infty$ , so (2.71) becomes

$$(\rho_1 + \rho_2)\omega^2 - 2(\rho_2 Uk)\omega + \rho_2 U^2 k^2 - ((\rho_1 - \rho_2)g + \gamma k^2) |k| = 0. \quad (2.72)$$

If there is no relative flow, that is  $U = 0$ , then (2.72) reduces to

$$\omega^2 = \frac{((\rho_1 - \rho_2)g + \gamma k^2) |k|}{\rho_1 + \rho_2}. \quad (2.73)$$

If  $\rho_1 > \rho_2$  then the right-hand side of (2.73) is positive, but if  $\rho_1 < \rho_2$ , it is negative for some values of  $k$ , namely

$$|k| < \sqrt{\frac{(\rho_2 - \rho_1)g}{\gamma}}. \quad (2.74)$$

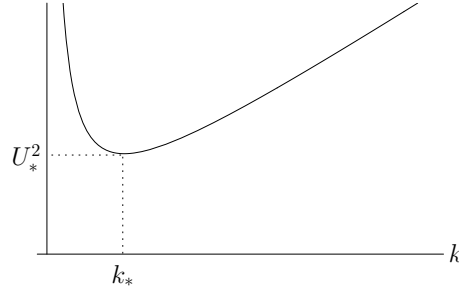

Figure 2.6: The right-hand side of (2.75) versus wavenumber  $k$ .

For these wavenumbers,  $\omega$  is pure imaginary, so the disturbance grows exponentially. Hence the situation with the denser fluid above the lighter fluid is (not surprisingly) unstable; this is known as the *Rayleigh–Taylor instability*.

When  $U$  is nonzero, we can examine the discriminant of the quadratic equation (2.72) to find that  $\omega$  is complex (so the flow is unstable) when

$$U^2 > \left( \frac{\rho_1 + \rho_2}{\rho_1 \rho_2} \right) \left( \frac{(\rho_1 - \rho_2)g + \gamma k^2}{|k|} \right). \quad (2.75)$$

Assuming  $\rho_1 > \rho_2$  (so the lighter fluid is on top), the right-hand side of (2.75) tends to infinity as  $|k| \rightarrow 0$  and as  $|k| \rightarrow \infty$ , with a minimum at  $|k| = k_* = \sqrt{(\rho_1 - \rho_2)g/\gamma}$  (see figure 2.6). This corresponds to a critical value of  $U$ , given by

$$U_*^2 = \frac{2(\rho_1 + \rho_2)}{\rho_1 \rho_2} \sqrt{\gamma(\rho_1 - \rho_2)g}. \quad (2.76)$$

If  $U > U_*$ , then there is a band of values of  $k$  for which (2.75) is satisfied and for which  $\omega$  is therefore complex. In other words the flow is unstable if the velocity of the upper fluid exceeds this critical value. This *Kelvin–Helmholtz instability* is responsible for the formation of waves by wind blowing over the sea.

## 2.4 Internal gravity waves in a stratified fluid

Now we consider waves in a fluid that is incompressible, so the density of each fluid element is conserved, *i.e.*

$$\frac{D\rho}{Dt} = 0 \quad \Leftrightarrow \quad \nabla \cdot \mathbf{u} = 0. \quad (2.77)$$

However, we no longer assume that the density is constant. The aim is to study waves in a stratified fluid, where the density varies with depth, for example in the sea, where  $\rho$  depends on the salinity of the water. We therefore start with a stationary solution of the form

$$\mathbf{u} = \mathbf{0}, \quad \rho = \rho_0(z), \quad p = p_0(z). \quad (2.78)$$

Stokes waves may be viewed as a special case of (2.78) in which  $\rho_0(z)$  is piecewise constant. From the momentum equation (2.1c), with  $\mathbf{g} = -g\hat{\mathbf{e}}_z$ , we find that the pressure must take the form

$$p_0(z) = p_a - g \int_0^z \rho_0(\zeta) d\zeta, \quad (2.79)$$

where  $p_a$  is a constant reference pressure.

Now we linearise about (2.78), setting

$$\mathbf{u} = \mathbf{0} + \mathbf{u}', \quad \rho = \rho_0(z) + \rho', \quad p = p_0(z) + p', \quad (2.80)$$

where the primed variables are again assumed to be small. With all nonlinear terms neglected, the equations reduce to

$$\frac{\partial \rho'}{\partial t} + w' \frac{d\rho_0}{dz} = 0, \quad \frac{\partial u'}{\partial x} + \frac{\partial v'}{\partial y} + \frac{\partial w'}{\partial z} = 0, \quad (2.81a)$$

$$\rho_0 \frac{\partial u'}{\partial t} = -\frac{\partial p'}{\partial x}, \quad \rho_0 \frac{\partial v'}{\partial t} = -\frac{\partial p'}{\partial y}, \quad \rho_0 \frac{\partial w'}{\partial t} = -\frac{\partial p'}{\partial z} - \rho' g, \quad (2.81b)$$

in which  $(u', v', w')$  are the components of  $\mathbf{u}'$ . We now eliminate  $u'$ ,  $v'$ ,  $\rho'$  and  $p'$  from these equations to obtain a single equation for  $w'$ . Cross-differentiating the horizontal momentum equations and using the second conservation-of-mass equation we find that

$$-\frac{\partial^2 p'}{\partial x^2} - \frac{\partial^2 p'}{\partial y^2} = \rho_0 \frac{\partial}{\partial t} \left( \frac{\partial u'}{\partial x} + \frac{\partial v'}{\partial y} \right) = -\rho_0 \frac{\partial^2 w'}{\partial z \partial t}. \quad (2.82)$$

Taking the time derivative of the vertical momentum equation and using the first conservation-of-mass equation we find that

$$\rho_0 \frac{\partial^2 w'}{\partial t^2} = -\frac{\partial^2 p'}{\partial z \partial t} - g \frac{\partial \rho'}{\partial t} = -\frac{\partial^2 p'}{\partial z \partial t} + g w' \frac{d\rho_0}{dz}. \quad (2.83)$$

Then elimination of  $p'$  between (2.82) and (2.83) leads to

$$\frac{\partial^2}{\partial t^2} \left( \frac{\partial^2 w'}{\partial x^2} + \frac{\partial^2 w'}{\partial y^2} + \frac{\partial^2 w'}{\partial z^2} \right) = \frac{g}{\rho_0} \frac{d\rho_0}{dz} \left( \frac{\partial^2 w'}{\partial x^2} + \frac{\partial^2 w'}{\partial y^2} - \frac{1}{g} \frac{\partial^3 w'}{\partial z \partial t^2} \right). \quad (2.84)$$

To get an idea of the behaviour of the solutions to this equation, we briefly examine a simplified version based on the following assumptions. We consider purely two-dimensional disturbances so that  $w'$  is a function only of  $x$ ,  $z$  and  $t$ . We also suppose that

$$\beta = \frac{1}{\rho_0} \frac{d\rho_0}{dz} \quad (2.85)$$

is constant, which occurs if  $\rho_0$  is proportional to  $e^{\beta z}$ . Finally, we assume that gravity dominates and we may thus neglect the final term multiplied by  $1/g$  in (2.84), to obtain

$$\frac{\partial^2}{\partial t^2} \left( \frac{\partial^2 w'}{\partial x^2} + \frac{\partial^2 w'}{\partial z^2} \right) = \beta g \frac{\partial^2 w'}{\partial x^2}. \quad (2.86)$$

We can look for propagating two-dimensional waves by setting

$$w'(x, z, t) = Ae^{i(kx \cos \alpha + kz \sin \alpha - \omega t)}, \quad (2.87)$$

where the amplitude  $A$  is arbitrary,  $k$  is the wavenumber, and the direction of propagation makes an angle  $\alpha$  with the  $x$ -axis. Substitution of (2.87) into (2.86) results in the dispersion relation

$$\omega^2 = -\beta g \cos^2 \alpha. \quad (2.88a)$$

Hence waves travel with a positive frequency  $\omega$  provided  $\beta$  is negative. If  $\beta$  is positive (so the density *decreases* with depth) then  $\omega$  is imaginary: the fluid is unstably stratified. The most unstable waves have  $\alpha = 0$  or  $\pi$ , so they travel in the horizontal direction.

Note that we can check *a posteriori* whether the term we omitted from (2.84) actually is negligible. With the extra term included, (2.88a) becomes

$$\left(1 - \frac{i\beta \sin \alpha}{k}\right) \omega^2 = -\beta g \cos^2 \alpha, \quad (2.88b)$$

so the approximation is good provided  $\beta \ll k$ , that is, if the wavelength is much smaller than the length-scale over which  $\rho_0$  varies.

## 2.5 Inertial waves in a rotating fluid

Now we examine the possibility of waves in a constant-density fluid rotating with constant angular velocity  $\boldsymbol{\Omega}$ . If gravity is neglected then, as shown in section 1, the governing equations are

$$\boldsymbol{\nabla} \cdot \mathbf{u} = 0, \quad \frac{\partial \mathbf{u}}{\partial t} + (\mathbf{u} \cdot \boldsymbol{\nabla})\mathbf{u} + 2\boldsymbol{\Omega} \times \mathbf{u} + \boldsymbol{\Omega} \times (\boldsymbol{\Omega} \times \mathbf{x}) = -\frac{1}{\rho} \boldsymbol{\nabla} p. \quad (2.89)$$

This can be simplified by using the identity

$$\boldsymbol{\Omega} \times (\boldsymbol{\Omega} \times \mathbf{x}) \equiv -\frac{1}{2} \boldsymbol{\nabla} (|\boldsymbol{\Omega} \times \mathbf{x}|^2), \quad (2.90)$$

which may easily be proved by taking components. Hence the momentum equation may be written in the form

$$\frac{\partial \mathbf{u}}{\partial t} + (\mathbf{u} \cdot \boldsymbol{\nabla})\mathbf{u} + 2\boldsymbol{\Omega} \times \mathbf{u} = -\frac{1}{\rho} \boldsymbol{\nabla} P, \quad (2.91)$$

where the *reduced pressure*  $P$  is defined to be

$$P = p - \frac{\rho}{2} |\boldsymbol{\Omega} \times \mathbf{x}|^2. \quad (2.92)$$

We look for small disturbances by linearising about the uniform steady state  $\mathbf{u} = \mathbf{0}$ ,  $P = \text{const}$  and find that the perturbations satisfy

$$\boldsymbol{\nabla} \cdot \mathbf{u}' = 0, \quad \frac{\partial \mathbf{u}'}{\partial t} + 2\boldsymbol{\Omega} \times \mathbf{u}' = -\frac{1}{\rho} \boldsymbol{\nabla} P'. \quad (2.93)$$



Equation (2.93) describes large-scale flows in the Earth's atmosphere.<sup>3</sup> In steady flow, (2.93) implies that  $\mathbf{u}' \cdot \nabla P' = 0$ , which explains why the wind is usually parallel to isobars (lines of constant pressure).

If we now take the curl of (2.93b) and make use of (2.93a) when expanding the vector triple product, we obtain

$$\frac{\partial}{\partial t}(\nabla \times \mathbf{u}') = 2(\boldsymbol{\Omega} \cdot \nabla)\mathbf{u}'. \quad (2.94)$$

Applying another time derivative and a curl to (2.94), we obtain

$$\frac{\partial^2}{\partial t^2} [\nabla \times (\nabla \times \mathbf{u}')] = 2(\boldsymbol{\Omega} \cdot \nabla) \frac{\partial}{\partial t}(\nabla \times \mathbf{u}'). \quad (2.95)$$

On the left-hand side, we can now expand the double curl using the vector identity  $\nabla \times (\nabla \times \mathbf{f}) \equiv \nabla(\nabla \cdot \mathbf{f}) - \nabla^2 \mathbf{f}$ , and apply (2.93a) once more. On the right-hand side we can substitute using (2.94). We obtain

$$\frac{\partial^2}{\partial t^2} (\nabla^2 \mathbf{u}') + 4(\boldsymbol{\Omega} \cdot \nabla)^2 \mathbf{u}' = 0. \quad (2.96)$$

Substituting in a plane wave proportional to  $e^{i(\mathbf{k} \cdot \mathbf{x} - \omega t)}$  we obtain the dispersion relation

$$\omega^2 = \frac{4(\boldsymbol{\Omega} \cdot \mathbf{k})^2}{|\mathbf{k}|^2} \quad (2.97)$$

Since  $\omega$  is always real, these waves are always stable. Observe that the frequency depends only on the direction of  $\mathbf{k}$ , and not on its magnitude. The highest frequencies are obtained when the wavevector  $\mathbf{k}$  is aligned with the rotation axis  $\boldsymbol{\Omega}$ , and indeed the fastest wavespeeds are obtained in this direction also.

## 2.6 Some other wave models

### Electromagnetic waves

In free space (where there are no charges or currents) the electric field  $\mathbf{E}$  and magnetic field  $\mathbf{B}$  satisfy *Maxwell's equations*

$$\nabla \cdot \mathbf{E} = 0, \quad \nabla \times \mathbf{E} = -\mu \frac{\partial \mathbf{B}}{\partial t}, \quad \nabla \cdot \mathbf{B} = 0, \quad \nabla \times \mathbf{B} = \epsilon \frac{\partial \mathbf{E}}{\partial t}, \quad (2.98)$$

where  $\epsilon$  and  $\mu$  are positive constants known as the *permittivity* and *permeability* respectively. It is straightforward by cross-differentiation to find that  $\mathbf{E}$  and  $\mathbf{B}$  both satisfy the wave equation

$$\frac{\partial^2 \mathbf{E}}{\partial t^2} = c^2 \nabla^2 \mathbf{E}, \quad \frac{\partial^2 \mathbf{B}}{\partial t^2} = c^2 \nabla^2 \mathbf{B}, \quad (2.99)$$

where  $c = 1/\sqrt{\epsilon\mu}$ . Hence free space supports non-dispersive electromagnetic waves moving at constant speed  $c$ , and  $c$  represents the *speed of light* in a vacuum.

<sup>3</sup>The linearisation is valid provided the *Rossby number*  $\text{Ro} = U/L\Omega$  is small, where  $U$  and  $L$  are typical scales for  $\mathbf{u}$  and  $\mathbf{x}$  respectively.

### Waves on an elastic string or membrane

Consider an elastic string, of mass  $m$  per unit length, stretched along the  $x$ -axis to a tension  $T$ . Suppose the string undergoes small transverse displacements so that its position at time  $t$  is given by  $z = w(x, t)$ . It is easy to show that these displacements are governed by the one-dimensional wave equation

$$\frac{\partial^2 w}{\partial t^2} = c^2 \frac{\partial^2 w}{\partial x^2}, \quad (2.100a)$$

with  $c = \sqrt{T/m}$ . Thus the string transmits non-dispersive waves at constant speed  $c$ .

This theory is easily generalised to describe an elastic *membrane* stretched to a tension  $T$  across the plane  $z = 0$ . Now small transverse displacements satisfy the two-dimensional wave equation

$$\frac{\partial^2 w}{\partial t^2} = c^2 \left( \frac{\partial^2 w}{\partial x^2} + \frac{\partial^2 w}{\partial y^2} \right), \quad (2.100b)$$

where  $c = \sqrt{T/\sigma}$  and  $\sigma$  is now the mass of the membrane per unit area. Again the wave-speed  $c$  is constant.

### Waves on an elastic plate

Unlike a membrane, an elastic plate has a significant *bending stiffness*  $B$ . It can be shown that small one-dimensional transverse displacements of an unstretched plate satisfy the *beam equation*

$$\sigma \frac{\partial^2 w}{\partial t^2} + B \frac{\partial^4 w}{\partial x^4} = 0, \quad (2.101)$$

where  $\sigma$  is the area density as above. The waves governed by (2.101) are dispersive, with the dispersion relation given by

$$\omega = \pm k^2 \sqrt{\frac{B}{\sigma}}. \quad (2.102)$$

For two-dimensional displacements, (2.101) is generalised to

$$\sigma \frac{\partial^2 w}{\partial t^2} + B \nabla^4 w = 0, \quad (2.103)$$

where  $\nabla^4 = (\nabla^2)^2$  is the *biharmonic* operator.

### Elastic waves in an isotropic elastic solid

It may be shown that small displacements  $\mathbf{u}$  of an isotropic elastic medium satisfy the *Navier equation*

$$\rho \frac{\partial^2 \mathbf{u}}{\partial t^2} = (\lambda + 2\mu) \nabla (\nabla \cdot \mathbf{u}) - \mu \nabla \times (\nabla \times \mathbf{u}), \quad (2.104)$$

in which  $\rho$  is the density, while  $\lambda$  and  $\mu$  are called the *Lamé constants*. (Roughly speaking,  $\lambda$  measures a material's resistance to compression and  $\mu$  its resistance to shear.) It is straightforward to show that (2.104) supports two different kinds of waves with different wave-speeds. First taking the divergence of (2.104), we find that  $(\nabla \cdot \mathbf{u})$  satisfies the wave equation

$$\frac{\partial^2(\nabla \cdot \mathbf{u})}{\partial t^2} = c_p^2 \nabla^2(\nabla \cdot \mathbf{u}), \quad (2.105)$$

where  $c_p^2 = (\lambda + 2\mu)/\rho$ . Equation (2.105) describes *pressure waves* or *P-waves* moving at speed  $c_p$ . On the other hand, taking the curl of (2.104) results in an equation describing *shear waves* or *S-waves*, namely

$$\frac{\partial^2(\nabla \times \mathbf{u})}{\partial t^2} = c_s^2 \nabla^2(\nabla \times \mathbf{u}), \quad (2.106)$$

where  $c_s^2 = \mu/\rho$ .

The existence of two different wave speeds explains why, following an underground earthquake, *two* initial shocks are felt at the surface: the P-waves arrive first, followed by the S-waves.

## Quantum mechanics

A quantum-mechanical particle of mass  $m$ , moving in one-dimension under a potential  $V(x)$ , is described by the *Schrödinger equation*

$$i\hbar \frac{\partial \Psi}{\partial t} = -\frac{\hbar^2}{2m} \frac{\partial^2 \Psi}{\partial x^2} + V(x)\Psi, \quad (2.107)$$

where  $\hbar$  is Planck's constant. The so-called *wave function*  $\Psi$  is related to the probability density function  $P(x, t)$ , measuring the probability of finding the particle at position  $x$  at time  $t$ , by

$$P(x, t) = |\Psi(x, t)|^2. \quad (2.108)$$

In three dimensions, the second-order  $x$ -derivative in (2.107) is replaced by  $\nabla^2$ .

With just one  $t$ -derivative on the left-hand side, (2.107) does not at first glance resemble a wave equation at all. However, if we set  $\Psi = u + iv$  and, for simplicity, ignore the potential  $V$  we find that the real and imaginary parts of  $\Psi$  satisfy the *beam equation* (2.101):

$$\frac{\partial^2 u}{\partial t^2} + \left(\frac{\hbar}{2m}\right)^2 \frac{\partial^4 u}{\partial x^4} = \frac{\partial^2 v}{\partial t^2} + \left(\frac{\hbar}{2m}\right)^2 \frac{\partial^4 v}{\partial x^4} = 0. \quad (2.109)$$

Hence (2.107) supports dispersive waves and, if  $V$  is constant, the dispersion relation is

$$\omega = \frac{\hbar k^2}{2m} + \frac{V}{\hbar}. \quad (2.110)$$

## 3 Theories for linear waves

### 3.1 Introduction

In this section we present several methods for analysing linear wave problems. In finite domains, the well-known technique of *separation of variables* allows the natural modes and natural frequencies to be determined. Then any solution may be expressed as a superposition of such modes. In infinite domains, instead it is more relevant to seek *travelling waves* and determine the dispersion relation between their frequency and wavenumber. Again, an arbitrary wave motion may then be considered as a superposition of such travelling waves, and this is clarified by use of the *Fourier transform*. It is often difficult to invert the Fourier transforms encountered in practice. Nevertheless, good estimates of the solutions may be obtained using the *method of stationary phase*. Alternatively, linear hyperbolic problems may be solved by the *method of characteristics*.

Finally, we combine these methods to analyse the flow past a thin wing at sub- and supersonic speeds.

### 3.2 Separation of variables

This technique is suitable for solving linear partial differential equations in finite domains. To apply the method, choose a coordinate system in which the domain boundaries are coordinate surfaces.

#### Example 1: acoustic waves in a box

Consider one-dimensional waves in a box of length  $L$ , where the two ends  $x = 0$  and  $x = L$  are fixed. Thus the velocity potential  $\phi$  satisfies the one-dimensional wave equation

$$\frac{\partial^2 \phi}{\partial t^2} = c_0^2 \frac{\partial^2 \phi}{\partial x^2}, \quad (3.1a)$$

subject to the boundary conditions

$$\frac{\partial \phi}{\partial x} = 0 \quad \text{at } x = 0, x = L. \quad (3.1b)$$

We look for a time-periodic solution of the form

$$\phi(x, t) = f(x)e^{-i\omega t}, \quad (3.2)$$

where the real part is assumed. This supposes that the gas all oscillates at a single frequency  $\omega$ , assume positive without loss of generality; such a motion is called a *normal mode*. Substitution into (3.1) leads to

$$\frac{d^2 f}{dx^2} + \left(\frac{\omega}{c_0}\right)^2 f = 0, \quad \frac{df}{dx}(0) = \frac{df}{dx}(L) = 0. \quad (3.3)$$

This is an *eigenvalue problem*, which admits nontrivial solutions of the form

$$f = A \cos\left(\frac{n\pi x}{L}\right), \quad (3.4)$$

only if  $\omega$  takes special values, namely

$$\omega_n = \frac{n\pi c_0}{L}, \quad (3.5)$$

where  $n$  is a positive integer. Equation (3.5) defines a countably infinite set of frequencies at which the gas may oscillate without forcing, and these are known as the *natural* or *resonant frequencies* of the pipe.

Since the problem (3.1) is linear and homogeneous, the separable solutions found above may be superimposed. Thus

$$\phi(x, t) = \sum_{n=1}^{\infty} \cos\left(\frac{n\pi x}{L}\right) \left\{ B_n \cos\left(\frac{n\pi c_0 t}{L}\right) + C_n \sin\left(\frac{n\pi c_0 t}{L}\right) \right\} \quad (3.6)$$

satisfies (3.1) for any values of the arbitrary constants  $B_n$  and  $C_n$ . If we impose the initial conditions

$$\phi = f(x), \quad \frac{\partial \phi}{\partial t} = g(x) \quad \text{at } t = 0, \quad (3.7)$$

then the constants may be evaluated using the theory of Fourier series:

$$B_n = \frac{2}{L} \int_0^L f(x) \cos\left(\frac{n\pi x}{L}\right) dx, \quad C_n = \frac{2}{n\pi c_0} \int_0^L g(x) \cos\left(\frac{n\pi x}{L}\right) dx. \quad (3.8)$$

Now, suppose the left-hand end of the box is oscillated, so at time  $t$  its position is  $x = ae^{-i\omega t}$ , where  $a$  is small. The left-hand boundary condition for  $\phi$  is thus modified to

$$\frac{\partial \phi}{\partial x} = -i\omega a e^{-i\omega t} \quad \text{at } x = ae^{-i\omega t}. \quad (3.9a)$$

As shown in section 2, it is consistent, when linearising for small  $a$  and  $\phi$ , to apply this boundary conditions on  $x = 0$  rather than  $x = ae^{-i\omega t}$ , that is

$$\frac{\partial \phi}{\partial x} = -i\omega a e^{-i\omega t} \quad \text{at } x = 0. \quad (3.9b)$$

Now, if we seek a separable solution  $\phi(x, t) = f(x)e^{-i\omega t}$ , we find that  $f$  must satisfy

$$\frac{d^2 f}{dx^2} + \left(\frac{\omega}{c_0}\right)^2 f = 0, \quad \frac{df}{dx}(0) = -i\omega a, \quad \frac{df}{dx}(L) = 0, \quad (3.10)$$

which is easily solved to give

$$f = -ic_0 a \operatorname{cosec} \left( \frac{\omega L}{c_0} \right) \cos \left( \frac{\omega(L-x)}{c_0} \right). \quad (3.11)$$

Notice that the amplitude of  $f$  (and hence also of  $\phi$ ) becomes unbounded as  $\omega$  approaches one of the natural frequencies  $\omega_n$ . This is the phenomenon of *resonance* and explains (among other things) how many musical instruments work: you can create large-amplitude sound waves by driving a column of air close to one of its resonant frequencies.

If  $\omega$  is at one of the resonant frequencies, then there is no time-periodic solution for  $\phi$ . We can instead look for a so-called *secular* solution, in which the amplitude grows linearly with time, by trying

$$\phi(x, t) = (f(x) + tg(x))e^{i\omega_n t}. \quad (3.12)$$

Substitution into the wave equation leads to two differential equations for  $f$  and  $g$ , whose solution, subject to the boundary conditions is

$$f(x) = -\frac{iac_0}{2\omega_n L} \left\{ 2\omega_n(L-x) \sin \left( \frac{\omega_n x}{c_0} \right) - c_0 \cos \left( \frac{\omega_n x}{c_0} \right) \right\} + A \cos \left( \frac{\omega_n x}{c_0} \right), \quad (3.13a)$$

$$g(x) = -\frac{ac_0^2}{L} \cos \left( \frac{\omega_n x}{c_0} \right), \quad (3.13b)$$

where  $A$  is arbitrary.

In practice, if  $\omega$  is at or close to one of the resonant frequencies, then the amplitude of the oscillations eventually becomes so large that our linearisation is no longer valid. The nonlinear terms that we have neglected become significant and prevent the amplitude from growing without bound. It is also likely that viscous effects may become important in very large-amplitude oscillations.

It is straightforward to extend the above analysis to higher dimensions. For example, normal modes in gas confined to the two-dimensional box  $\{0 < x < L, 0 < y < b\}$  take the form

$$\phi = ae^{-i\omega t} \cos \left( \frac{n\pi x}{L} \right) \cos \left( \frac{i\pi y}{b} \right), \quad (3.14)$$

where  $n$  and  $i$  are integers. There is thus a doubly-infinite family of natural frequencies, given by

$$\omega_{n,i}^2 = \pi^2 c_0^2 \left( \frac{n^2}{L^2} + \frac{i^2}{b^2} \right). \quad (3.15)$$

In general, there is an infinite family of normal modes for each spatial dimension in the problem. For the three-dimensional box  $\{0 < x < L, 0 < y < b, 0 < z < h\}$ , the modes and corresponding frequencies are

$$\phi = ae^{-i\omega t} \cos \left( \frac{n\pi x}{L} \right) \cos \left( \frac{i\pi y}{b} \right) \cos \left( \frac{j\pi z}{h} \right), \quad \omega_{n,i,j}^2 = \pi^2 c_0^2 \left( \frac{n^2}{L^2} + \frac{i^2}{b^2} + \frac{j^2}{h^2} \right), \quad (3.16)$$

for any integer values of  $n, i, j$ .

**Example 2: spherical waves**

Suppose gas is contained in the annular region  $a < r < b$ , where  $r$  is the usual spherical polar coordinate. For spherically symmetric waves, the velocity potential  $\phi(r, t)$  satisfies

$$\frac{\partial^2 \phi}{\partial t^2} = c_0^2 \nabla^2 \phi = \frac{c_0^2}{r} \frac{\partial^2}{\partial r^2} (r\phi), \quad \frac{\partial \phi}{\partial r} = 0 \text{ on } r = a, \quad \frac{\partial \phi}{\partial r} = 0 \text{ on } r = b. \quad (3.17)$$

We look for normal modes of the form

$$\phi(r, t) = f(r)e^{-i\omega t}, \quad (3.18)$$

so that  $f$  must satisfy

$$\frac{d^2}{dr^2} (rf) + \left(\frac{\omega}{c_0}\right)^2 (rf) = 0, \quad \frac{df}{dr}(a) = \frac{df}{dr}(b) = 0. \quad (3.19)$$

Hence  $f$  is given by

$$f = \frac{A \cos(kr) + B \sin(kr)}{r}, \quad (3.20)$$

where  $k = \omega/c_0$ , and application of the boundary conditions leads to the following system of equations for the arbitrary constants  $A$  and  $B$ :

$$\begin{pmatrix} \cos(ka) + ka \sin(ka) & \sin(ka) - ka \cos(ka) \\ \cos(kb) + kb \sin(kb) & \sin(kb) - kb \cos(kb) \end{pmatrix} \begin{pmatrix} A \\ B \end{pmatrix} = \mathbf{0}. \quad (3.21)$$

For a nontrivial solution to exist, the determinant of the left-hand side must be zero, which leads to the equation

$$(1 + k^2 ab) \tan(k(b-a)) = k(b-a). \quad (3.22)$$

Given  $a$  and  $b$ , this transcendental equation has a countably infinite set of solutions for  $k$ , each corresponding to a natural frequency.

**Example 3: waves in a circle**

Consider waves in gas confined to the circle  $r < a$ , where  $r$  is the plane polar radial coordinate. The radially-symmetric wave equation reads

$$\frac{\partial^2 \phi}{\partial t^2} = c_0^2 \nabla^2 \phi = c_0^2 \left( \frac{\partial^2 \phi}{\partial r^2} + \frac{1}{r} \frac{\partial \phi}{\partial r} \right), \quad (3.23a)$$

and, assuming the edge  $r = a$  is fixed and that  $\phi$  is bounded as  $r \rightarrow 0$ , we have the boundary conditions

$$|\phi| < \infty \text{ as } r \rightarrow 0, \quad \frac{\partial \phi}{\partial r} = 0 \text{ at } r = a. \quad (3.23b)$$

We seek normal modes of the form

$$\phi(r, t) = f(r)e^{-i\omega t} \quad (3.24)$$

and find that  $f$  must satisfy

$$\frac{d^2 f}{dr^2} + \frac{1}{r} \frac{df}{dr} + \left(\frac{\omega}{c_0}\right)^2 f = 0, \quad |f| < \infty \text{ as } r \rightarrow 0, \quad \frac{df}{dr}(a) = 0. \quad (3.25a)$$

If we define  $\xi = kr$ , where  $k = \omega/c_0$ , then (3.25a) becomes

$$\xi^2 \frac{d^2 f}{d\xi^2} + \xi \frac{df}{d\xi} + \xi^2 f = 0, \quad |f| < \infty \text{ as } \xi \rightarrow 0, \quad \frac{df}{d\xi}(ka) = 0. \quad (3.25b)$$

This is *Bessel's equation* of order zero, and the two linearly independent solutions are denoted  $J_0(\xi)$  and  $Y_0(\xi)$ , although only  $J_0(\xi)$  is bounded as  $\xi \rightarrow 0$ .

We must therefore have  $f = AJ_0(\xi)$  for some constant  $A$ , and the condition at  $r = a$  is satisfied if

$$ka = \xi_{0,i} \quad (i = 1, 2, \dots), \quad (3.26a)$$

where  $\xi_{0,1} < \xi_{0,2} < \dots$  are the extrema of  $J_0(\xi)$ . As indicated in figure 3.1, there are an infinite number of these and  $\xi_{0,i} \rightarrow \infty$  as  $i \rightarrow \infty$ . The natural frequencies of the gas are thus given by

$$\omega_i = \frac{c_0 \xi_{0,i}}{a} \quad (i = 1, 2, \dots). \quad (3.26b)$$

Next we drop the assumption of radial symmetry and consider waves in a circular pipe of radius  $a$  and length  $L$ , with closed ends. In terms of cylindrical polar coordinates  $(r, \theta, z)$ , the velocity potential  $\phi$  satisfies

$$\frac{\partial^2 \phi}{\partial t^2} = c_0^2 \nabla^2 \phi = c_0^2 \left( \frac{\partial^2 \phi}{\partial r^2} + \frac{1}{r} \frac{\partial \phi}{\partial r} + \frac{1}{r^2} \frac{\partial^2 \phi}{\partial \theta^2} + \frac{\partial^2 \phi}{\partial z^2} \right), \quad (3.27a)$$

$$|\phi| < \infty \text{ as } r \rightarrow 0, \quad \frac{\partial \phi}{\partial r} = 0 \text{ at } r = a, \quad \frac{\partial \phi}{\partial z} = 0 \text{ at } z = 0, L, \quad (3.27b)$$

plus the condition that  $\phi$  must be a  $2\pi$ -periodic function of  $\theta$ .

It is readily shown that time-periodic separable solutions satisfying the boundary conditions are of the form

$$\phi(r, \theta, z, t) = f(r)(A \cos(n\theta) + B \sin(n\theta)) \cos\left(\frac{j\pi z}{L}\right) e^{-i\omega t}, \quad (3.28)$$

where  $n$  and  $j$  are integers. It follows that  $f$  satisfies

$$r^2 \frac{d^2 f}{dr^2} + r \frac{df}{dr} + (k^2 r^2 - n^2) f = 0, \quad |f| < \infty \text{ as } r \rightarrow 0, \quad \frac{df}{dr}(a) = 0, \quad (3.29a)$$



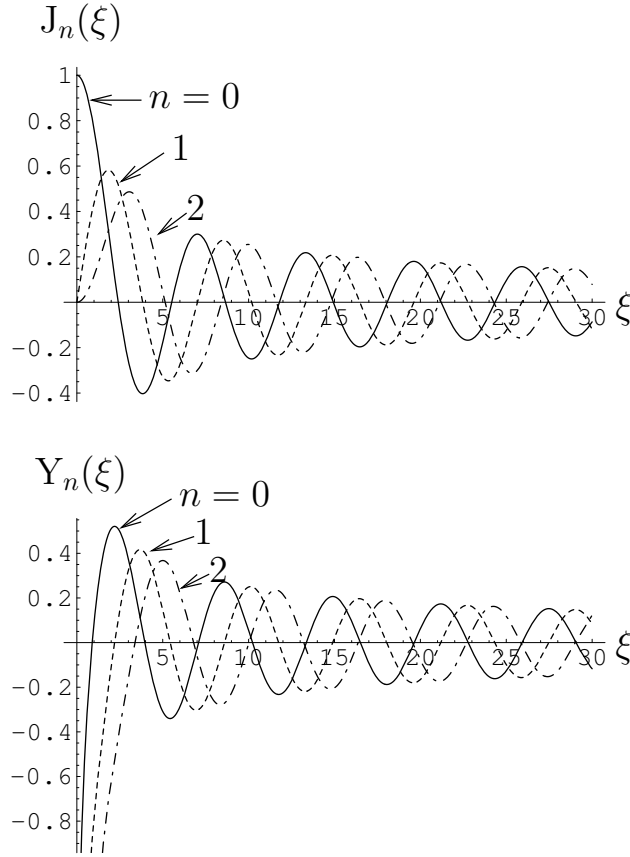

Figure 3.1: Plots of the first few Bessel functions  $J_n(\xi)$  and  $Y_n(\xi)$  for  $n = 0$  (solid),  $n = 1$  (dashed),  $n = 2$  (dot-dashed).

where

$$k^2 = \frac{\omega^2}{c_0^2} - \frac{j^2 \pi^2}{L^2}. \quad (3.29b)$$

Setting  $\xi = kr$  as before, we find that (3.29a) becomes

$$\xi^2 \frac{d^2 f}{d\xi^2} + \xi \frac{df}{d\xi} + (\xi^2 - n^2) f = 0, \quad |f| < \infty \text{ as } \xi \rightarrow 0, \quad \frac{df}{d\xi}(ka) = 0. \quad (3.29c)$$

This is *Bessel's equation* of order  $n$ , whose two linearly dependent solutions are denoted  $J_n(\xi)$  and  $Y_n(\xi)$ ; the cases  $n = 0, 1, 2$  are plotted in figure 3.1. For any integer  $n$ ,  $Y_n(\xi)$  is singular as  $\xi \rightarrow 0$ , so we must have  $f = AJ_n(\xi)$  for some constant  $A$ , and the condition at  $r = a$  is satisfied if

$$ka = \xi_{n,i} \quad (i = 1, 2, \dots), \quad (3.30)$$

where  $\xi_{n,1} < \xi_{n,2} < \dots$  are the extrema of  $J_n(\xi)$ . Again, there are an infinite number of these and  $\xi_{n,i} \rightarrow \infty$  as  $i \rightarrow \infty$ .

The natural frequencies of the pipe are thus given by

$$\omega_{n,i,j}^2 = c_0^2 \left( \frac{j^2 \pi^2}{L^2} + \frac{\xi_{n,i}^2}{a^2} \right), \quad (3.31)$$

where  $n$ ,  $i$  and  $j$  are arbitrary integers, so there is a triply-infinite family of normal modes that depend on the three spatial coordinates  $(r, \theta, z)$ .

### 3.3 Travelling waves

On an infinite domain, instead of normal modes, we can look for travelling harmonic waves, and attempt to determine the dispersion relation between the frequency and the wavenumber.

#### Example 1: waveguide

Linear waves propagating in the  $x$ -direction through gas contained between two rigid walls at  $z = 0$  and  $z = h$  can be described by a velocity potential of the form

$$\phi(x, z, t) = A \cos\left(\frac{n\pi z}{h}\right) e^{i(kx - \omega t)}, \quad (3.32)$$

where  $n$  is an integer. By substituting this into the wave equation, we find the dispersion relation

$$\omega^2 = c_0^2 \left( k^2 + \frac{n^2 \pi^2}{h^2} \right). \quad (3.33a)$$

The speed of propagation of waves along the waveguide is thus given by

$$c_p^2 = \frac{\omega^2}{k^2} = c_0^2 \left( 1 + \frac{n^2 \pi^2}{h^2 k^2} \right). \quad (3.33b)$$

Whenever  $n$  is nonzero, these waves are *dispersive*, since  $c_p$  varies with  $k$ .

#### Multidimensional travelling waves

If the dependent variable (say  $\phi$ ) depends on multiple spatial variables, we can look for a general harmonic travelling wave by setting

$$\phi = a e^{i(kx + \ell y + mz - \omega t)} = a e^{i(\mathbf{k} \cdot \mathbf{x} - \omega t)}, \quad (3.34)$$

where

$$\mathbf{k} = (k, \ell, m)^T \quad (3.35)$$

is the *wavenumber vector*. The direction of  $\mathbf{k}$  represents the direction in which the waves propagate, while the magnitude of  $\mathbf{k}$  is related to the wavelength  $\lambda$  by  $|\mathbf{k}| = 2\pi/\lambda$ .

The *phase velocity* of the waves is

$$\mathbf{c}_p = \frac{\omega \mathbf{k}}{|\mathbf{k}|^2}. \quad (3.36)$$

For nondispersive waves, we would expect the wave speed  $|\mathbf{c}_p|$  to be independent of  $\mathbf{k}$ , and we see from (3.36) that this is true if and only if

$$\omega = c_p |\mathbf{k}|, \quad (3.37)$$

where  $c_p$  is constant. If the dispersion relation takes any form other than (3.37), then the waves are dispersive.

### Example 2: internal gravity waves

As shown in section 2, small-amplitude waves in a stratified fluid of ambient density  $\rho_0 = \text{Re}^{\beta z}$  are governed by the equation

$$\frac{\partial^2}{\partial t^2} \left( \frac{\partial^2 w'}{\partial x^2} + \frac{\partial^2 w'}{\partial y^2} + \frac{\partial^2 w'}{\partial z^2} \right) = \beta g \left( \frac{\partial^2 w'}{\partial x^2} + \frac{\partial^2 w'}{\partial y^2} - \frac{1}{g} \frac{\partial^3 w'}{\partial z \partial t^2} \right). \quad (3.38)$$

If we try a travelling-wave solution of the form

$$w' = a e^{i(\mathbf{k} \cdot \mathbf{x} - \omega t)}, \quad (3.39)$$

we find that the dispersion relation is

$$\omega^2 = -\frac{\beta g(k^2 + \ell^2)}{|\mathbf{k}|^2 - i\beta m}, \quad (3.40)$$

and the waves are thus dispersive. Recall that  $\beta < 0$  for stable stratification. Nevertheless, there are two complex roots for  $\omega$  whenever  $m$  is nonzero and, since (3.40) is an equation for  $\omega^2$ , at least one of these roots must have a positive imaginary part. Thus the amplitude grows exponentially whenever  $m$  is nonzero, and the fluid is always unstable to waves in the  $z$ -direction.

## 3.4 Fourier transform

In section 3.2, we showed that a general flow in a finite domain may be written as a superposition of normal modes. An initial-value problem may thus be solved by choosing the weightings of the different modes appropriately. Similarly, the general solution in an infinite domain may be written as a superposition of harmonic waves, and initial conditions can be imposed by a suitable choice of the weighting function. Here we show how this can be achieved in some simple cases using the *Fourier transform*.

Given a suitable function  $f$ , we define the Fourier transform  $\hat{f}$  by

$$\hat{f}(k) = \int_{-\infty}^{\infty} f(x) e^{-ikx} dx. \quad (3.41)$$

We will now quote some basic properties of the Fourier transform.

### 1. Inverse Fourier transform

If we have calculated  $\widehat{f}$ , the original function  $f$  is recovered using

$$f(x) = \frac{1}{2\pi} \int_{-\infty}^{\infty} \widehat{f}(k) e^{ikx} dk. \quad (3.42a)$$

### 2. Convolution theorem

If  $\widehat{f}$  can be written as the product of two Fourier transforms that we know, say  $\widehat{f}(k) = \widehat{g}(k)\widehat{h}(k)$ , then  $f$  is the *convolution* of  $g$  and  $h$ , that is

$$f(x) = (g \star h)(x) = \int_{-\infty}^{\infty} g(\xi)h(x - \xi) d\xi. \quad (3.42b)$$

### 3. Fourier transform of derivatives

The Fourier transform turns  $x$ -derivatives into multiples of  $k$ , specifically

$$\frac{d^n f}{dx^n} = (ik)^n \widehat{f}. \quad (3.42c)$$

Hence ordinary differential equations are transformed into algebraic equations, and partial differential equations into ordinary differential equations.

## Stokes waves

We now illustrate the use of the Fourier transform to solve the problem of two-dimensional Stokes waves on a semi-infinite layer of fluid. The velocity potential  $\phi(x, z, t)$  and free-surface displacement  $z = \eta(x, t)$  satisfy the equations and boundary conditions

$$\frac{\partial^2 \phi}{\partial x^2} + \frac{\partial^2 \phi}{\partial z^2} = 0 \quad z < 0, \quad (3.43a)$$

$$\frac{\partial \phi}{\partial z} = \frac{\partial \eta}{\partial t}, \quad \frac{\partial \phi}{\partial t} + g\eta = 0 \quad z = 0, \quad (3.43b)$$

$$\phi \rightarrow 0 \quad z \rightarrow -\infty. \quad (3.43c)$$

The problem is closed by specifying the initial displacement and velocity of the free surface. We suppose the fluid starts from rest with the free surface given by  $z = \eta_0(x)$ , so that

$$\eta = \eta_0(x), \quad \frac{\partial \eta}{\partial t} = 0 \quad \text{at } t = 0. \quad (3.43d)$$

We take a Fourier transform in  $x$ , denoted with  $\widehat{\phantom{x}}$  as above, so the problem becomes

$$\frac{\partial^2 \widehat{\phi}}{\partial z^2} - k^2 \widehat{\phi} = 0 \quad z < 0, \quad (3.44a)$$

$$\frac{\partial \widehat{\phi}}{\partial z} = \frac{\partial \widehat{\eta}}{\partial t}, \quad \frac{\partial \widehat{\phi}}{\partial t} + g\widehat{\eta} = 0 \quad z = 0, \quad (3.44b)$$

$$\widehat{\phi} \rightarrow 0 \quad z \rightarrow -\infty, \quad (3.44c)$$

$$\widehat{\eta} = \widehat{\eta}_0, \quad \frac{\partial \widehat{\eta}}{\partial t} = 0 \quad t = 0. \quad (3.44d)$$

It follows that

$$\widehat{\phi} = A(k, t)e^{|k|z}, \quad (3.45)$$

where  $A$  satisfies

$$|k|A = \frac{\partial \widehat{\eta}}{\partial t}, \quad \frac{\partial A}{\partial t} + g\widehat{\eta} = 0. \quad (3.46)$$

Solving these equations and applying the initial conditions, we find that

$$\widehat{\eta} = \widehat{\eta}_0 \cos(\omega t), \quad A = -\frac{\omega \widehat{\eta}_0}{|k|} \sin(\omega t), \quad (3.47)$$

where the frequency  $\omega(k)$  is given by the dispersion relation

$$\omega(k) = \sqrt{g|k|}. \quad (3.48)$$

The evolution of the free surface is then found by inverting the transform, resulting in

$$\eta(x, t) = \frac{1}{2\pi} \int_{-\infty}^{\infty} \widehat{\eta}_0(k) \cos(\omega(k)t) e^{ikx} dk. \quad (3.49a)$$

If the cosine is expanded out, to give

$$\eta(x, t) = \frac{1}{4\pi} \int_{-\infty}^{\infty} \widehat{\eta}_0(k) \left( e^{i(kx-\omega t)} + e^{i(kx+\omega t)} \right) dk, \quad (3.49b)$$

it becomes clear that this represents a superposition of waves travelling up- and downstream with phase speed  $c_p = \omega(k)/k$ .

If the fluid does not start from rest, say

$$\frac{\partial \eta}{\partial t} = w_0(x) \quad \text{at } t = 0, \quad (3.50)$$

then (3.49) becomes

$$\eta(x, t) = \frac{1}{2\pi} \int_{-\infty}^{\infty} \left( \widehat{\eta}_0(k) \cos(\omega(k)t) + \frac{\widehat{w}_0(k)}{\omega(k)} \sin(\omega(k)t) \right) e^{ikx} dk. \quad (3.51)$$

This expression may be applied to generalised Stokes waves problems (with, for example, finite depth or surface tension) by modifying the dispersion relation for  $\omega(k)$  appropriately. However, except for very simple dispersion relations, it is difficult to evaluate the inversion integrals exactly. Instead, we will show below in section 3.5 how the large-time asymptotic behaviour of the solution may be estimated.

### Multidimensional Fourier transform

The methods outlined above can be generalised to higher spatial dimensions. For a function of three spatial dimensions  $f(x, y, z)$ , for example, we can define the triple Fourier transform

$$\widehat{f}(k, \ell, m) = \int_{-\infty}^{\infty} \int_{-\infty}^{\infty} \int_{-\infty}^{\infty} f(x, y, z) e^{-i(kx + \ell y + mz)} dx dy dz. \quad (3.52a)$$

If we define the wavenumber vector  $\mathbf{k} = (k, \ell, m)^T$  as before, then a convenient shorthand for (3.52a) is

$$\widehat{f}(\mathbf{k}) = \iiint_{\mathbb{R}^3} f(\mathbf{x}) e^{-i(\mathbf{k} \cdot \mathbf{x})} d\mathbf{x}, \quad (3.52b)$$

and the inverse transform then reads

$$f(\mathbf{x}) = \frac{1}{8\pi^3} \iiint_{\mathbb{R}^3} \widehat{f}(\mathbf{k}) e^{i(\mathbf{k} \cdot \mathbf{x})} d\mathbf{k}. \quad (3.53)$$

Consider for example the inertial wave equation (3.38). The triple Fourier transform  $\widehat{w}$  of  $w'$  satisfies

$$(|\mathbf{k}|^2 - i\beta m) \frac{\partial^2 \widehat{w}}{\partial t^2} = \beta g (k^2 + \ell^2) \widehat{w}. \quad (3.54)$$

If, for example, we start with

$$w' = w_0(\mathbf{x}), \quad \frac{\partial w'}{\partial t} = 0 \quad \text{at } t = 0, \quad (3.55)$$

then the appropriate solution of (3.54) is

$$\widehat{w} = \widehat{w}_0(\mathbf{k}) \cos(\omega(\mathbf{k})t), \quad (3.56)$$

where  $\omega(\mathbf{k})$  is given by the dispersion relation (3.40). The inverse transform thus gives

$$w'(\mathbf{x}, t) = \frac{1}{8\pi^3} \iiint_{\mathbb{R}^3} \widehat{w}_0(\mathbf{k}) \cos(\omega(\mathbf{k})t) e^{i(\mathbf{k} \cdot \mathbf{x})} d\mathbf{k}, \quad (3.57a)$$

or

$$w'(\mathbf{x}, t) = \frac{1}{16\pi^3} \iiint_{\mathbb{R}^3} \widehat{w}_0(\mathbf{k}) \left( e^{i(\mathbf{k} \cdot \mathbf{x} + \omega(\mathbf{k})t)} + e^{i(\mathbf{k} \cdot \mathbf{x} - \omega(\mathbf{k})t)} \right) d\mathbf{k}, \quad (3.57b)$$

which may be identified as a superposition of harmonic waves with wavenumber vector  $\mathbf{k}$  and frequency  $\pm\omega(\mathbf{k})$ . Now the superposition takes place over all possible vectors  $\mathbf{k}$ , that is over all possible wavenumbers and propagation directions.

If  $\omega(\mathbf{k})$  is complex for any  $\mathbf{k}$  such that  $\widehat{w}_0(\mathbf{k})$  is nonzero, then (3.57) implies that  $w'$  grows exponentially in time and the base state is therefore unstable. From the dispersion relation (3.40), we see that  $\omega$  is complex whenever  $m$  is nonzero. The perturbation therefore grows exponentially unless  $\widehat{w}_0(k, \ell, m) \equiv 0$  whenever  $m \neq 0$ , which occurs only if  $w_0$  is independent of  $z$ . Hence the base state in this case is unstable to all  $z$ -dependent perturbations.

### 3.5 Method of stationary phase

#### Motivation

In section 3.4, we used a Fourier transform to solve the problem of two-dimensional Stokes waves on a semi-infinite fluid layer, subject to zero initial velocity and a given free-surface displacement  $\eta_0(x)$  at  $t = 0$ . From (3.49) we see that an observer travelling at speed  $V$ , so that his or her position at time  $t$  is  $x = Vt$ , will observe a free surface displacement

$$\eta(Vt, t) = \frac{1}{4\pi} \int_{-\infty}^{\infty} \widehat{\eta}_0(k) e^{i(kV - \omega(k))t} dk + \frac{1}{4\pi} \int_{-\infty}^{\infty} \widehat{\eta}_0(k) e^{i(kV + \omega(k))t} dk, \quad (3.58)$$

where  $\omega(k)$  is given by (3.48) or, in general, by some other dispersion relation.

The Fourier integrals in (3.58) are in general difficult to evaluate explicitly. To understand how they behave for large  $t$ , we now consider the general case

$$I(t) = \int_a^b f(k) e^{i\psi(k)t} dk, \quad (3.59)$$

where  $f$  and  $\psi$  are arbitrary functions, known as the *amplitude* and *phase* respectively, while  $a$  and  $b$  are fixed constants. We will start by illustrating the method for the simple cases in which  $\psi$  is a linear or quadratic function of  $k$ . We will apply some *ad hoc* asymptotic estimates, but emphasise that these can be made rigorous by using more careful analysis.

#### Example 1: linear $\psi(k)$

First consider the simple case where  $\psi(k)$  is a *linear* function of  $k$ , that is

$$\psi(k) = \alpha + \beta k \quad (3.60)$$

for some real constants  $\alpha$  and  $\beta$ , so that  $I(t)$  takes the form

$$I(t) = e^{i\alpha t} \int_a^b f(k) e^{i\beta k t} dk. \quad (3.61)$$

When  $t$  is large,  $e^{i\psi(k)t}$  is a highly oscillatory function. The positive and negative contributions to the integral  $I(t)$  almost exactly cancel each other out, with the cancellation becoming perfect in the limit  $t \rightarrow \infty$ . This is shown schematically in figure 3.2 for the case  $f(k) = (1 + (k - 1)^2)^{-1}$ ,  $\psi(k) = 1 + k$  and  $t = 10$ .

The integral  $I(t)$  therefore tends to zero as  $t \rightarrow \infty$ ; in particular, the *Riemann–Lebesgue Lemma* tells us that

$$I(t) = O\left(\frac{1}{\beta t}\right) \quad \text{as } t \rightarrow \infty. \quad (3.62)$$

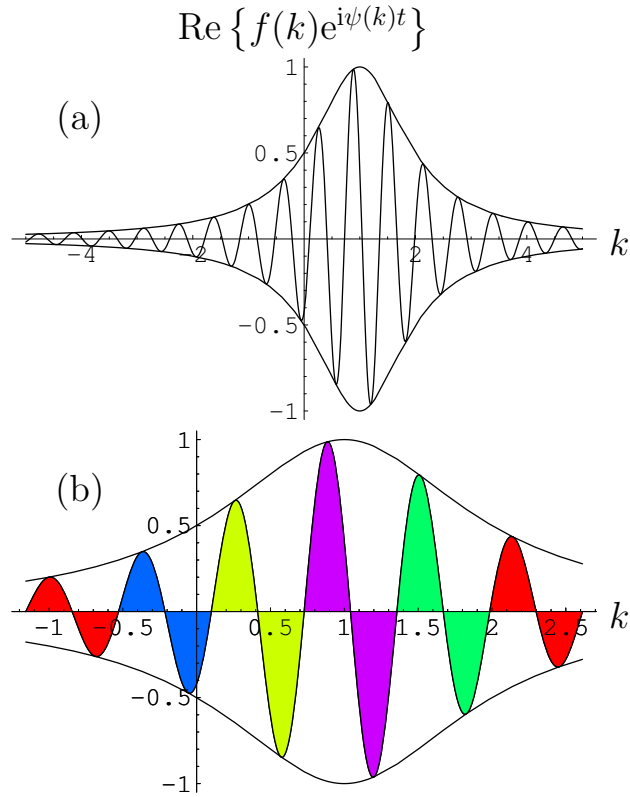

Figure 3.2: (a) The real part of  $f(k)e^{i\psi(k)t}$  plotted versus  $k$  with  $f(k) = (1 + (k - 1)^2)^{-1}$ ,  $\psi(k) = 1 + k$  and  $t = 10$ . (b) A close-up of (a) indicating cancellation of the positive and negative contributions.

(To prove (3.62), integrate (3.61) by parts to obtain

$$I(t)e^{-i\alpha t} = \frac{1}{i\beta t} \left\{ \left[ f(k)e^{i\beta kt} \right]_a^b - \int_a^b f'(k)e^{i\beta kt} dk \right\}. \quad (3.63)$$

The term in braces may be bounded using the assumed continuity of  $f'$ , resulting in  $|I(t)| \leq M/(\beta t)$  for some constant  $M$ .) The result (3.62) also applies in the limit  $a \rightarrow -\infty$ ,  $b \rightarrow +\infty$  provided  $|f'(k)|$  is integrable over this range.

**Example 2: quadratic  $\psi(k)$**

Next consider the case where  $\psi(k)$  is a *quadratic* function, say

$$\psi(k) = \alpha + \gamma k^2, \quad (3.64)$$

where  $\alpha$  and  $\gamma$  are real constants. Note that this  $\psi(k)$  has a single extremum which we have assumed, without loss of generality, to be at  $k = 0$ . In figure 3.3 we plot  $\text{Re}\{f(k)e^{i\psi(k)t}\}$  versus  $k$  for the case  $f(k) = (1 + (k - 1)^2)^{-1}$ ,  $\psi(k) = 1 + k^2$  and  $t = 10$ .



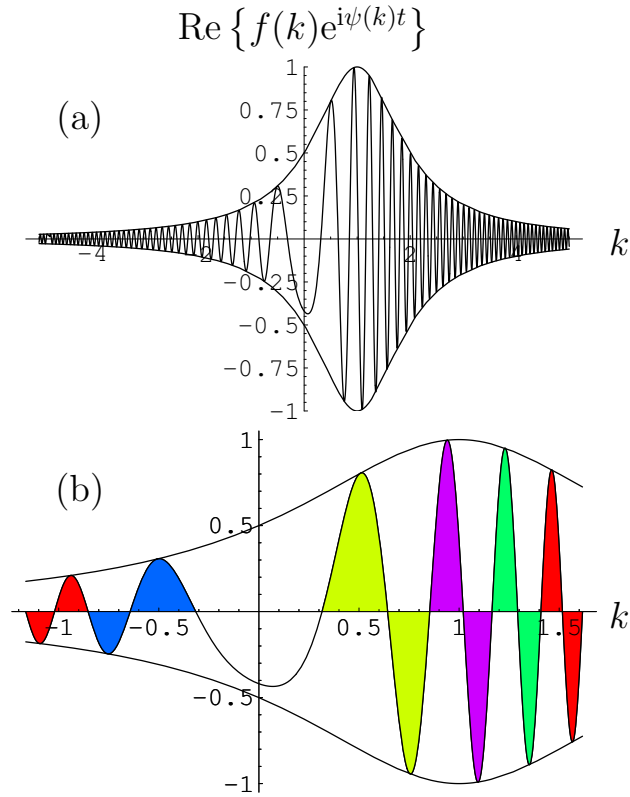

Figure 3.3: (a) The real part of  $f(k)e^{i\psi(k)t}$  plotted versus  $k$  with  $f(k) = (1 + (k-1)^2)^{-1}$ ,  $\psi(k) = 1 + k^2$  and  $t = 10$ . (b) A close-up of (a) showing how cancellation of the positive and negative contributions fails near  $k = 0$ .

Again the positive and negative contributions approximately cancel, with increasing accuracy as  $|k|$  increases. However, near  $k = 0$ , where  $\psi(k)$  is stationary, the cancellation is relatively poor. For large  $t$ , the behaviour of  $I(t)$  is therefore dominated by the contribution from a neighbourhood of  $k = 0$ .

With  $\psi(k)$  given by (3.64),  $I(t)$  takes the form

$$I(t) = e^{iat} \int_a^b f(k)e^{i\gamma k^2 t} dk, \quad (3.65)$$

If  $a$  and  $b$  are both positive, then  $k$  is positive throughout the range of integration, so we may change integration variable to  $\ell = k^2$ , resulting in

$$I(t) = e^{iat} \int_{a^2}^{b^2} \frac{f(\sqrt{\ell})}{2\sqrt{\ell}} e^{i\gamma \ell t} d\ell. \quad (3.66)$$

Since  $\ell$  is bounded away from zero, the Riemann–Lebesgue Lemma applies and tells us that  $I(t) = O(1/\gamma t)$ . By an analogous argument, we also have  $I(t) = O(1/\gamma t)$  if  $a$  and  $b$  are both negative.

If  $a < 0 < b$ , then our integration region includes the origin, so the change of variable that gives rise to (3.66) is invalid. However, as shown schematically in figure 3.3, we expect the main contribution to  $I(t)$  to come from a neighbourhood of  $k = 0$ , so we split up the range of integration as follows:

$$I(t)e^{-i\alpha t} = \int_a^{-\epsilon} f(k)e^{i\gamma k^2 t} dk + \int_{\epsilon}^b f(k)e^{i\gamma k^2 t} dk + \int_{-\epsilon}^{\epsilon} f(k)e^{i\gamma k^2 t} dk, \quad (3.67a)$$

where  $\epsilon$  is a fixed small constant. The Riemann–Lebesgue Lemma applies to the first two integrals, leaving us with

$$I(t)e^{-i\alpha t} = \int_{-\epsilon}^{\epsilon} f(k)e^{i\gamma k^2 t} dk + O\left(\frac{1}{\gamma t}\right). \quad (3.67b)$$

If  $\epsilon$  is sufficiently small then, to leading order, we may replace  $f(k)$  with  $f(0)$ . Supposing for the moment that  $\gamma$  is positive, the change of variable  $s = k\sqrt{\gamma t}$  thus leads to

$$I(t)e^{-i\alpha t} \sim \frac{1}{\sqrt{\gamma t}} \int_{-\epsilon\sqrt{\gamma t}}^{\epsilon\sqrt{\gamma t}} f(0)e^{is^2} ds + O\left(\frac{1}{\gamma t}\right). \quad (3.67c)$$

A straightforward contour integral shows that

$$\int_{-R}^R e^{is^2} ds \rightarrow (1+i)\sqrt{\frac{\pi}{2}} + O\left(\frac{1}{R}\right) \quad (3.68)$$

as  $R \rightarrow \infty$ . We therefore deduce from (3.67c) that the leading-order behaviour of  $I(t)$  is

$$I(t) \sim (1+i)e^{i\alpha t} f(0) \sqrt{\frac{\pi}{2\gamma t}} + O\left(\frac{1}{\gamma t}\right) \quad \text{as } t \rightarrow \infty. \quad (3.69)$$

This establishes mathematically what is illustrated schematically in figure 3.3. With  $\psi(k)$  given by (3.64), the cancellation in the integrand of  $I(t)$  is poor near  $k = 0$ , and  $I(t)$  therefore converges to zero less rapidly than it does when  $\psi(k)$  is linear. Furthermore, the large-time behaviour of  $I(t)$  is dominated by the behaviour of the integrand near  $k = 0$ ; hence only  $f(0)$  appears in (3.69).

Recall that (3.67c) was obtained under the assumption that  $\gamma$  is positive. For negative  $\gamma$ , the change of variable  $s = k\sqrt{-\gamma t}$  leads to

$$I(t) \sim \frac{e^{i\alpha t}}{\sqrt{-\gamma t}} \int_{-\epsilon\sqrt{-\gamma t}}^{\epsilon\sqrt{-\gamma t}} f(0)e^{-is^2} ds + O\left(\frac{1}{\gamma t}\right), \quad (3.70)$$

and the result

$$\int_{-R}^R e^{-is^2} ds \rightarrow (1-i)\sqrt{\frac{\pi}{2}} + O\left(\frac{1}{R}\right) \quad \text{as } R \rightarrow \infty, \quad (3.71)$$

which is an obvious corollary of (3.68), then leads to

$$I(t) \sim (1-i)e^{i\alpha t} f(0) \sqrt{\frac{\pi}{-2\gamma t}} + O\left(\frac{1}{\gamma t}\right) \quad \text{as } t \rightarrow \infty. \quad (3.72a)$$

We can combine (3.69) and (3.72a) into the handy form

$$I(t) \sim f(0)e^{i(\alpha t \pm \pi/4)} \sqrt{\frac{\pi}{|\gamma|t}} \quad (3.72b)$$

as  $t \rightarrow \infty$ , where the  $\pm$  corresponds to the sign of  $\gamma$ .

### The general case

Now we generalise the analysis given above to arbitrary exponents  $\psi(k)$ . We will assume only that  $\psi$  is real-valued and twice continuously differentiable.

First suppose that  $\psi'(k)$  is nowhere zero on  $[a, b]$  and hence is either uniformly positive or uniformly negative. It follows that  $\psi(k)$  is strictly monotonic on  $[a, b]$ , so we can invert the one-to-one relation between  $k$  and  $\psi(k)$  to write

$$k = \kappa(\psi). \quad (3.73)$$

Thus  $I(t)$  may be written as

$$I(t) = \int_a^b f(k)e^{i\psi(k)t} dk = \int_{\psi(a)}^{\psi(b)} f(\kappa(\psi))e^{i\psi t} \kappa'(\psi) d\psi, \quad (3.74)$$

and the Riemann–Lebesgue Lemma implies that  $I(t) = O(1/t)$ .

Next suppose that  $\psi'(k)$  has a simple zero at just one point  $k_* \in [a, b]$ . We divide up the integration range as follows:

$$I(t) = \int_a^{k_*-\epsilon} f(k)e^{i\psi(k)t} dk + \int_{k_*+\epsilon}^b f(k)e^{i\psi(k)t} dk + \int_{k_*-\epsilon}^{k_*+\epsilon} f(k)e^{i\psi(k)t} dk, \quad (3.75)$$

where  $\epsilon$  is a fixed small constant. Since  $\psi$  is monotonic over each of the intervals  $[a, k_*-\epsilon]$  and  $[k_*+\epsilon, b]$ , the first two integrals in (3.75) are  $O(1/t)$ , by the argument given above. In the final integral, we use the smallness of  $\epsilon$  to approximate  $f$  and  $\psi$  near  $k = k_*$  as

$$f(k) \sim f(k_*), \quad \psi(k) \sim \psi(k_*) + \frac{\psi''(k_*)}{2}(k - k_*)^2, \quad (3.76)$$

since  $\psi'(k_*) = 0$ . Thus (3.75) becomes

$$I(t) \sim \int_{k_*-\epsilon}^{k_*+\epsilon} f(k_*)e^{i\psi(k_*)t} \exp\left(\frac{it\psi''(k_*)}{2}(k - k_*)^2\right) dk + O\left(\frac{1}{t}\right) \quad (3.77)$$

and, if  $\psi''(k_*)$  is positive, the change of variable

$$k = k_* + s\sqrt{\frac{2}{t\psi''(k_*)}} \quad (3.78)$$

leads to

$$I(t) \sim f(k_*)e^{i\psi(k_*)t} \sqrt{\frac{2}{\psi''(k_*)t}} \int_{-\epsilon\sqrt{\psi''(k_*)t/2}}^{\epsilon\sqrt{\psi''(k_*)t/2}} e^{is^2} ds + O\left(\frac{1}{t}\right). \quad (3.79)$$

Application of (3.68) thus leads to the estimate

$$I(t) \sim (1 + i)f(k_*)e^{i\psi(k_*)t} \sqrt{\frac{\pi}{\psi''(k_*)t}} + O\left(\frac{1}{t}\right) \quad (3.80)$$

as  $t \rightarrow \infty$ . An analogous argument may also be applied for the case where  $\psi''(k_*)$  is negative, and leads to the general result

$$I(t) \sim f(k_*)e^{i(\psi(k_*)t \pm \pi/4)} \sqrt{\frac{2\pi}{|\psi''(k_*)|t}} \quad (3.81)$$

as  $t \rightarrow \infty$ , where the  $\pm$  takes the sign of  $\psi''(k_*)$ . In either case, we see that  $I(t) = O(1/\sqrt{t})$  rather than  $O(1/t)$ , and that the dominant contribution to  $I(t)$  comes from a neighbourhood of  $k = k_*$ . Recall that this is where the phase  $\psi(k)$  is stationary, and the asymptotic procedure leading to (3.81) is therefore known as the *method of stationary phase*.

If  $\psi'(k)$  has multiple zeros, then each may be considered in isolation by employing a domain decomposition analogous to (3.75). Hence the leading-order behaviour of  $I(t)$  is simply the sum of all the contributions of the form (3.81) due to each point where  $\psi$  is stationary. It is also worth noting that, in deriving (3.81), we have assumed that  $\psi''(k_*)$  is nonzero. We will not bother here to spell out the generalised versions of (3.81) that apply to higher-order zeros of  $\psi'(k)$ .

### Group velocity

Now we are in a position to apply the estimate (3.81) to (3.58), which we write as

$$\eta(Vt, t) = I_+(t) + I_-(t), \quad \text{where} \quad I_{\pm}(t) = \frac{1}{4\pi} \int_{-\infty}^{\infty} \widehat{\eta}_0(k) e^{i(kV \mp \omega(k))t} dk. \quad (3.82)$$

Each integral  $I_{\pm}(t)$  is of the required form (3.59), with

$$a = -\infty, \quad b = \infty, \quad f(k) = \frac{\widehat{\eta}_0(k)}{4\pi}, \quad \psi(k) = Vk \mp \omega(k). \quad (3.83)$$

The method of stationary phase tells us that the main contribution to  $\eta$  comes from wavenumbers  $k = k_*$  where  $\psi$  is stationary, that is

$$\psi'(k_*) = V \mp \omega'(k_*) = 0. \quad (3.84)$$

Thus an observer travelling at speed  $V$  will see waves of wavenumber  $k_*$  satisfying (3.84). In other words, waves with wavenumber  $k$  travel at speed  $V = \pm c_g(k)$ , where

$$c_g(k) = \frac{dw}{dk} \quad (3.85)$$

is called the *group velocity*.

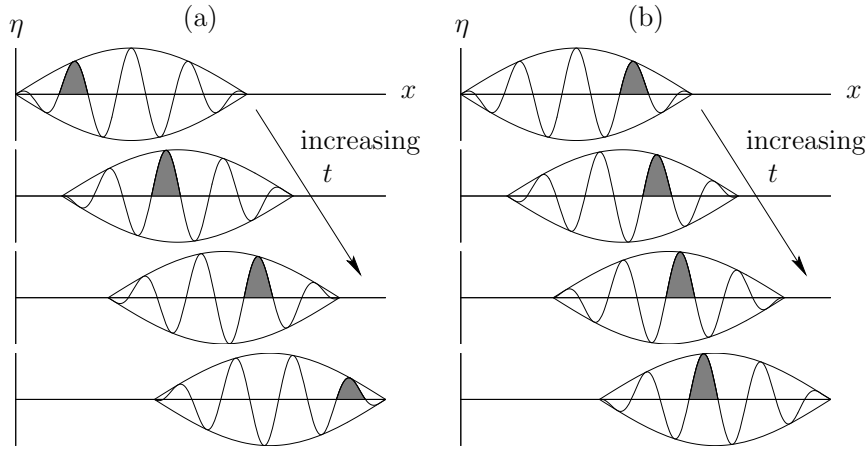

Figure 3.4: Schematic of a moving wave packet with (a)  $c_g < c_p$ , (b)  $c_g > c_p$ . One wave crest is highlighted to illustrate how it moves relative to the packet.

Notice that  $c_g(k)$  is different from the phase velocity  $c_p(k) = \omega/k$  unless  $\omega/k$  is constant, which occurs only for *non-dispersive* waves. At first glance, it might seem paradoxical that waves can travel at a group velocity different from their phase velocity. The explanation is that, after a long time, dispersive waves separate into *wave packets* corresponding to different wavenumbers. Within each wave packet, the waves move at speed  $c_p$ , but the packet as a whole moves at speed  $c_g$ .

This phenomenon is illustrated in figure 3.4 for a single wave packet travelling from left to right at speed  $c_g$ . The wave crests in the packet move with speed  $c_p$  so, if  $c_g < c_p$  then, as indicated in figure 3.4(a), the wave crests move through the packet, seeming to appear at the back and disappear at the front. This behaviour can be observed in the radiating ripples caused by throwing a stone into a pond. On the other hand, if the group velocity is greater than the phase velocity then the wave crests move more slowly than the wave packet, as shown in figure 3.4(b). This can sometimes be observed in very small ripples, which appear to move *backwards* relative to a radiating wave packet.

For gravity waves on deep water, the dispersion relation is

$$\omega(k) = \sqrt{g|k|}, \quad (3.86a)$$

so the phase and group velocities are given by

$$c_p = \frac{\sqrt{g|k|}}{k}, \quad c_g = \frac{\sqrt{g|k|}}{2k}. \quad (3.86b)$$

We therefore always have  $|c_g| < |c_p|$  in this case, that is the situation depicted in figure 3.4(a).

If surface tension  $\gamma$  is included then it may be shown, as in section 2, that the dispersion relation (3.86a) is modified to

$$\omega(k) = \sqrt{g|k| \left( 1 + \frac{\gamma k^2}{\rho g} \right)}. \quad (3.87)$$

It is straightforward to determine the group and phase velocities and hence show that

$$\frac{c_g}{c_p} = \frac{3}{2} - \left(1 + \frac{\gamma k^2}{\rho g}\right)^{-1}. \quad (3.88)$$

It follows that  $|c_g| < |c_p|$  when  $|k| < k_c$  and  $|c_g| > |c_p|$  when  $|k| > k_c$ , where the critical wavenumber  $k_c$  is given by

$$k_c = \sqrt{\frac{\rho g}{\gamma}}. \quad (3.89a)$$

This corresponds to a critical wavelength

$$\lambda_c = \frac{2\pi}{k_c} = 2\pi\sqrt{\frac{\gamma}{\rho g}}, \quad (3.89b)$$

known as the *capillary length*. Thus waves shorter than  $\lambda_c$  travel backwards relative to their wavepackets, like those depicted in figure 3.4(b). For water,  $\rho \approx 1000 \text{ kg m}^{-3}$  and  $\gamma \approx 0.07 \text{ N m}^{-1}$ , so the capillary length is about 1.7 cm.

### Example: localised disturbance

For the two Fourier integrals  $I_{\pm}(t)$  defined by (3.82), the phase and its derivatives are given by

$$\psi(k) = kV \mp \sqrt{g|k|}, \quad \psi'(k) = V \mp \frac{\sqrt{g|k|}}{2k}, \quad \psi''(k) = \pm \frac{\sqrt{g|k|}}{4k^2}. \quad (3.90)$$

Hence, at the critical wavenumber  $k_*$  where  $\psi$  is stationary, we have

$$k_* = \pm \frac{g}{4V^2}, \quad \psi(k_*) = \mp \frac{g}{4V}, \quad \psi''(k_*) = \pm \frac{2V^3}{g}. \quad (3.91)$$

Assuming that  $V$  is positive, this means that critical wavenumber is positive for  $I_+$  and negative for  $I_-$ . By applying the estimate (3.81) to each integral  $I_{\pm}(t)$ , we thus obtain the following asymptotic approximation for the free surface displacement:

$$\eta(Vt, t) \sim \frac{1}{4} \sqrt{\frac{g}{\pi V^3 t}} \left\{ \widehat{\eta}_0 \left( \frac{g}{4V^2} \right) e^{i(\pi/4 - gt/4V)} + \widehat{\eta}_0 \left( -\frac{g}{4V^2} \right) e^{i(gt/4V - \pi/4)} \right\}. \quad (3.92)$$

To make further progress, we need to specify the initial displacement  $\eta_0(x)$  so that we can determine its Fourier transform  $\widehat{\eta}_0(k)$ . Here we consider the example

$$\eta_0(x) = \frac{\epsilon a}{\pi(\epsilon^2 + x^2)}, \quad (3.93)$$

which represents a localised initial disturbance near  $x = 0$  and might model, for example, the ripples caused by throwing a stone into a pond. If  $\epsilon$  is small, then  $\eta_0(x)$  is approximately zero except near  $x = 0$ . Nevertheless,  $\eta_0$  has constant area, that is

$$\int_{-\infty}^{\infty} \eta_0(x) dx \equiv a, \quad (3.94)$$

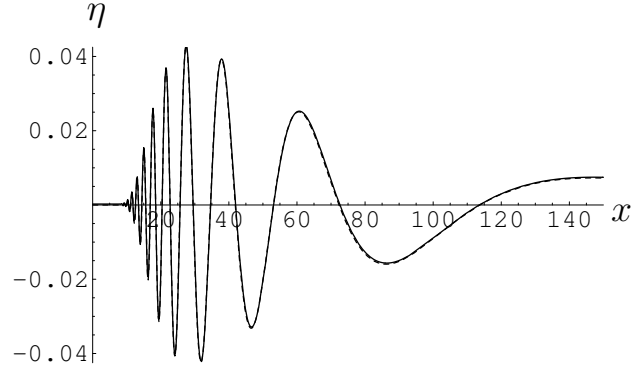

Figure 3.5: Free surface displacement  $\eta(x, t)$  given by (3.97) versus  $x$  with  $\eta_0(x) = -(\pi(1+x^2))^{-1}$  and  $t\sqrt{g} = 50$ . The dashed line shows the asymptotic approximation (3.96).

whatever the value of  $\epsilon$ . Hence, as  $\epsilon$  is reduced towards zero,  $\eta_0$  is concentrated in a vanishingly small neighbourhood, of size  $O(\epsilon)$ , near  $x = 0$ .<sup>1</sup>

The Fourier transform of  $\eta_0(x)$  is readily found by contour integration to be

$$\widehat{\eta}_0(k) = ae^{-\epsilon|k|}, \quad (3.95)$$

so (3.92) becomes

$$\eta(Vt, t) \sim \frac{a}{2} \sqrt{\frac{g}{\pi V^3 t}} e^{-\epsilon g/4V^2} \cos\left(\frac{gt}{4V} - \frac{\pi}{4}\right) \quad (3.96a)$$

or, substituting  $V = x/t$ ,

$$\eta(x, t) \sim \frac{at}{2} \sqrt{\frac{g}{\pi x^3}} e^{-\epsilon gt^2/4x^2} \cos\left(\frac{gt^2}{4x} - \frac{\pi}{4}\right). \quad (3.96b)$$

When  $\eta_0$  is given by (3.93), the inverse Fourier transform for  $\eta$  may be calculated exactly and written in the form

$$\eta(x, t) = \eta_0(x) - \frac{t\sqrt{g}}{2\sqrt{\pi}} \operatorname{Re} \left\{ \frac{1}{(1-ix)^{3/2}} \exp\left(-\frac{t^2 g}{4(1-ix)}\right) \operatorname{erfi}\left(\frac{t\sqrt{g}}{2\sqrt{1-ix}}\right) \right\} \quad (3.97)$$

where  $\operatorname{erfi}$  is the so-called *imaginary error function*, and we have chosen  $a = -1$ ,  $\epsilon = 1$  for simplicity. In figure 3.5, we compare this exact solution with our asymptotic approximation (3.96) when  $t\sqrt{g} = 50$ , showing excellent agreement.

If

$$\frac{x}{t} = V \gg \sqrt{\frac{\epsilon g}{2}}, \quad (3.98)$$

<sup>1</sup>In the limit  $\epsilon \rightarrow 0$ ,  $\eta_0(x)$  approaches  $a\delta(x)$ , where  $\delta$  is the so-called *Dirac delta-function*, which is defined to be zero for all nonzero  $x$  but to have unit area.

then (3.96) may be simplified further by approximating the exponential, so that

$$\eta(x, t) \sim \frac{at}{2} \sqrt{\frac{g}{\pi x^3}} \cos\left(\frac{gt^2}{4x} - \frac{\pi}{4}\right). \quad (3.99)$$

It may be shown that this is the universal behaviour of  $\eta$  far from an initial localised disturbance.

### 3.6 Method of characteristics

As shown in section 2, acoustic waves in one dimension satisfy the *wave equation*

$$\frac{\partial^2 \phi}{\partial t^2} - c_0^2 \frac{\partial^2 \phi}{\partial x^2} = 0, \quad (3.100)$$

which can be written in the form

$$\left(\frac{\partial}{\partial t} + c_0 \frac{\partial}{\partial x}\right) \left(\frac{\partial \phi}{\partial t} - c_0 \frac{\partial \phi}{\partial x}\right) = 0. \quad (3.101)$$

Hence, if we write

$$\Phi = \frac{\partial \phi}{\partial t} - c_0 \frac{\partial \phi}{\partial x}, \quad (3.102)$$

then we have

$$\frac{\partial \Phi}{\partial t} + c_0 \frac{\partial \Phi}{\partial x} = 0, \quad (3.103a)$$

which implies that

$$\frac{d\Phi}{dt} = 0 \quad \text{when} \quad \frac{dx}{dt} = c_0. \quad (3.103b)$$

It follows that  $\Phi$  is constant on the straight lines  $x - c_0 t = \text{const}$ , so that  $\Phi$  must be a function only of  $(x - c_0 t)$ . By an analogous argument, with the differential operators in (3.101) swapped, we find that

$$\left(\frac{\partial \phi}{\partial t} \pm c_0 \frac{\partial \phi}{\partial x}\right) = \text{const} \quad \text{when} \quad (x \pm c_0 t) = \text{const}. \quad (3.104)$$

The straight lines  $x \pm c_0 t = \text{const}$  are the *characteristics* of the partial differential equation (3.100). It is straightforward (*e.g.* by changing variables to  $\xi = x + c_0 t$  and  $\eta = x - c_0 t$ ) to show that the general solution of (3.100) is

$$\phi(x, t) = f(x - c_0 t) + g(x + c_0 t), \quad (3.105)$$

where the scalar functions  $f$  and  $g$  are arbitrary. If, for example, we impose the initial conditions

$$\phi = \phi_0(x), \quad \frac{\partial \phi}{\partial t} = v_0(x) \quad \text{at} \quad t = 0, \quad (3.106)$$



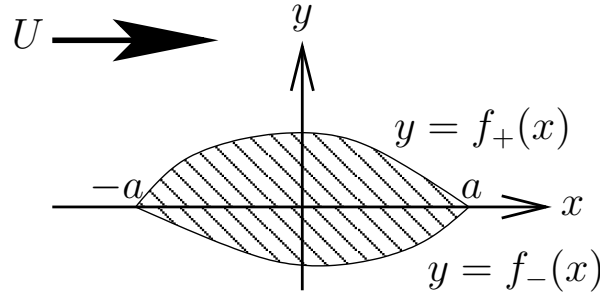

Figure 3.6: Schematic of a thin wing with upper and lower surfaces given by  $y = f_{\pm}(x)$ .

then  $f$  and  $g$  are readily determined, resulting in the so-called *D'Alembert solution*:

$$\phi(x, t) = \frac{1}{2} \left( \phi_0(x - c_0 t) + \phi_0(x + c_0 t) \right) + \frac{1}{2c_0} \int_{x-c_0 t}^{x+c_0 t} v_0(s) ds. \quad (3.107)$$

For a general second-order linear partial differential equation of the form

$$A \frac{\partial^2 \phi}{\partial t^2} + 2B \frac{\partial^2 \phi}{\partial x \partial t} + C \frac{\partial^2 \phi}{\partial x^2} = f, \quad (3.108)$$

where  $f$  may in general depend on  $\phi$ ,  $\partial\phi/\partial x$  and  $\partial\phi/\partial t$ , the *characteristics* are curves whose slopes are given by

$$\frac{dx}{dt} = \lambda, \quad \text{where} \quad A\lambda^2 - 2B\lambda + C = 0. \quad (3.109)$$

The equation is *hyperbolic* if these slopes are real and distinct, that is if  $B^2 > AC$ .

In the simple case where  $A$ ,  $B$  and  $C$  are constant and  $f$  is zero, (3.108) may be written as

$$A \left( \frac{\partial}{\partial t} + \lambda_1 \frac{\partial}{\partial x} \right) \left( \frac{\partial \phi}{\partial t} + \lambda_2 \frac{\partial \phi}{\partial x} \right) = 0, \quad (3.110a)$$

where  $\lambda_k$  ( $k = 1, 2$ ) are the roots of (3.109). We thus deduce (provided  $A$  is nonzero) that

$$\left( \frac{\partial \phi}{\partial t} + \lambda_i \frac{\partial \phi}{\partial x} \right) = \text{const} \quad \text{when} \quad x - \lambda_j t = \text{const}, \quad (3.110b)$$

where  $i \neq j \in \{1, 2\}$ , and the general solution of (3.108) is then

$$\phi(x, t) = f(x - \lambda_1 t) + g(x - \lambda_2 t). \quad (3.111)$$

## 3.7 Flow past a thin wing

### Equations and boundary conditions

Now we consider two-dimensional flow at speed  $U$  past a thin wing. As illustrated in figure 3.6, the wing is assumed to lie along the  $x$ -axis between  $x = -a$  and  $x = a$ , with

upper and lower surfaces given by  $y = f_+(x)$  and  $y = f_-(x)$  respectively. Since the wing is supposed to be thin, the flow is only slightly disturbed from a uniform velocity  $\mathbf{u} = U\hat{\mathbf{e}}_x$ . As shown in section 2, the disturbance potential therefore satisfies

$$(1 - M^2) \frac{\partial^2 \phi}{\partial x^2} + \frac{\partial^2 \phi}{\partial y^2} = 0, \quad (3.112a)$$

where  $M = U/c_0$  is the Mach number as before. The normal velocity on the wing must be zero, which leads, after linearisation, to the boundary conditions

$$\frac{\partial \phi}{\partial y} = U \frac{df_{\pm}}{dx} \quad \text{on } y = 0_{\pm}, \quad |x| < a. \quad (3.112b)$$

Elsewhere on  $y = 0$ , both the normal velocity  $v = \partial\phi/\partial y$  and the pressure are continuous, so the boundary conditions are

$$\left[ \frac{\partial \phi}{\partial x} \right]_{-}^{+} = \left[ \frac{\partial \phi}{\partial y} \right]_{-}^{+} = 0 \quad \text{on } y = 0, \quad |x| > a. \quad (3.112c)$$

The character of the solution to (3.112a), in particular the appropriate far field condition to apply to  $\phi$ , depends crucially on whether the flow is *subsonic* ( $M < 1$ ) or *supersonic* ( $M > 1$ ). We consider each case in turn below.

Once  $\phi$  has been determined, the pressure perturbation is given by the linearised Bernoulli equation:

$$p' = -\rho_0 U \frac{\partial \phi}{\partial x}. \quad (3.113)$$

Hence we can calculate the *lift*  $L$  experienced by the wing as

$$L = \int_{-a}^a -[p']_{-}^{+} dx = \rho_0 U \int_{-a}^a \left[ \frac{\partial \phi}{\partial x} \right]_{-}^{+} dx. \quad (3.114a)$$

Without loss of generality, we suppose that  $\phi$  is continuous across  $y = 0$  ahead of the wing, that is  $[\phi]_{-}^{+}$  is zero at  $x = -a$ . Then the lift reduces to

$$L = -\rho_0 U \Gamma, \quad \text{where } \Gamma = \phi(a, 0-) - \phi(a, 0+) \quad (3.114b)$$

is the *circulation* around the wing. This reproduces *Kutta–Joukowski Lift Theorem*, which is well known for *incompressible* flow past an aerofoil. In particular, if the circulation is zero, then the wing experiences no force at all, which is *D'Alembert's Paradox*.

### Subsonic flow

If  $M < 1$ , the partial differential equation (3.112a) is *elliptic*, and requires a condition on  $\phi$  to be imposed at infinity. We assume that the disturbance flow decays to zero far from the wing, that is

$$\nabla \phi \rightarrow \mathbf{0} \quad \text{as } |\mathbf{x}| \rightarrow \infty. \quad (3.115)$$

Now, (3.112a) can be transformed into Laplace's equation by defining

$$Y = \beta y, \quad \Phi = \beta \phi, \quad \text{where} \quad \beta = \sqrt{1 - M^2}. \quad (3.116)$$

Thus  $\Phi(x, Y)$  satisfies

$$\frac{\partial^2 \Phi}{\partial x^2} + \frac{\partial^2 \Phi}{\partial Y^2} = 0, \quad (3.117a)$$

$$\frac{\partial \Phi}{\partial Y} = U \frac{df_{\pm}}{dx} \quad Y = 0_{\pm}, \quad |x| < a, \quad (3.117b)$$

$$\left[ \frac{\partial \Phi}{\partial x} \right]_{-}^{+} = \left[ \frac{\partial \Phi}{\partial Y} \right]_{-}^{+} = 0 \quad Y = 0, \quad |x| > a, \quad (3.117c)$$

$$\frac{\partial \Phi}{\partial x}, \quad \frac{\partial \Phi}{\partial Y} \rightarrow 0 \quad x^2 + Y^2 \rightarrow \infty, \quad (3.117d)$$

which is identical to the problem of *incompressible* flow past the same wing. Thus, if we can calculate the incompressible potential  $\Phi_i(x, Y)$ , then the corresponding compressible potential is

$$\phi(x, y) = \frac{1}{\sqrt{1 - M^2}} \Phi_i \left( x, y\sqrt{1 - M^2} \right). \quad (3.118)$$

Notice that the disturbance flow grows in amplitude as the Mach number approaches 1, eventually invalidating our linearisation. This explains why the force experienced by an aerofoil increases dramatically as it approaches the speed of sound, which caused great difficulties for early attempts to break the "sound barrier".

The solution of (3.117) is particularly simple if the wing is *symmetric*, so that  $f_{-}(x) \equiv -f_{+}(x)$ . If so, then we can look for a solution that is symmetric about  $Y = 0$  and replace (3.117) with

$$\frac{\partial^2 \Phi}{\partial x^2} + \frac{\partial^2 \Phi}{\partial Y^2} = 0 \quad Y > 0, \quad (3.119a)$$

$$\frac{\partial \Phi}{\partial Y} = U \eta(x) \quad Y = 0, \quad (3.119b)$$

$$\frac{\partial \Phi}{\partial x}, \quad \frac{\partial \Phi}{\partial Y} \rightarrow 0 \quad x^2 + Y^2 \rightarrow \infty, \quad (3.119c)$$

where

$$\eta(x) = \begin{cases} \frac{df_{+}}{dx} & |x| < a, \\ 0 & |x| > a. \end{cases} \quad (3.120)$$

This problem can be solved by taking a Fourier transform in  $x$ . The Fourier transform of  $\partial \Phi / \partial Y$  is easily found to be

$$\frac{\partial \widehat{\Phi}}{\partial Y} = U \widehat{\eta} e^{-|k|Y} \quad (3.121)$$

so, by the convolution theorem,

$$\frac{\partial \Phi}{\partial Y} = U \eta \star g, \quad \text{where} \quad \widehat{g} = e^{-|k|Y}. \quad (3.122)$$

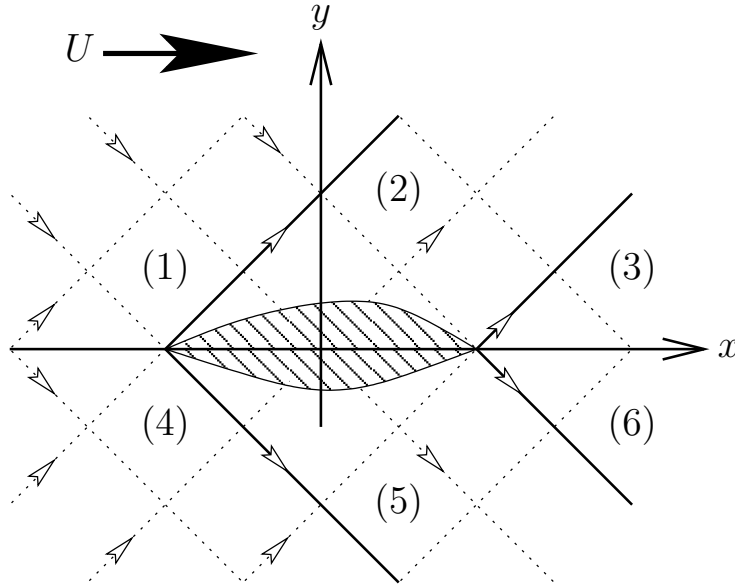

Figure 3.7: Schematic of the characteristics for supersonic flow past a thin wing.

By inverting  $\hat{g}$ , we obtain

$$g(x, Y) = \frac{Y}{\pi(x^2 + Y^2)} \quad (3.123)$$

and hence

$$\frac{\partial \Phi}{\partial Y} = U \int_{-\infty}^{\infty} \eta(\xi) g(x - \xi, Y) d\xi = \frac{U}{\pi} \int_{-a}^a \frac{Y f'_+(\xi) d\xi}{(x - \xi)^2 + Y^2}. \quad (3.124)$$

Finally, we integrate both sides with respect to  $Y$ , using the condition (3.119c) to obtain (up to an arbitrary constant)

$$\Phi = \frac{U}{2\pi} \int_{-a}^a \log((x - \xi)^2 + Y^2) f'_+(\xi) d\xi. \quad (3.125)$$

Thus the wing is represented by a *distribution of sources* along the  $x$ -axis. For an asymmetric wing with  $f_- \neq f_+$ , (3.125) must be generalised to include also a *distribution of vortices*.

### Supersonic flow

For the case  $M > 1$ , (3.112a) is hyperbolic and its general solution may be written as

$$\phi(x, y) = F(x - By) + G(x + By), \quad \text{where } B = \sqrt{M^2 - 1}. \quad (3.126)$$

Notice that  $F(x - By)$  and  $G(x + By)$  are constant on the characteristics  $x - By = \text{const}$  and  $x + By = \text{const}$  respectively. Instead of the far field condition (3.115), we now impose the condition of *causality*, namely that causes must occur before effects. With the flow

passing the wing from left to right, information therefore travels along the characteristics from left to right, as indicated by the arrows in figure 3.7.

We suppose that the flow upstream of the wing is undisturbed, that is

$$\phi \rightarrow 0 \quad \text{as } x \rightarrow -\infty. \quad (3.127)$$

It follows that  $F = C$  and  $G = -C$ , where  $C$  is a constant, along each of the characteristics that enter from  $x = -\infty$ . Thus  $\phi$  is zero throughout the regions marked (1) and (4) in figure 3.7. Equally, in regions (3) and (6) we see that the characteristics coming from  $x = -\infty$  without intersecting the wing force each of  $F$  and  $G$  to be constant, so that  $\phi = C_1$  say in region (3) and  $\phi = C_2$  say in region (6), where  $C_1$  and  $C_2$  are constants. Thus there are *zones of silence* in which  $\nabla\phi = \mathbf{0}$  both ahead of the wing and behind it, and the flow is only affected by the presence of the wing in the *regions of influence* (2) and (5).

First consider region (2). The characteristics  $x + By = \text{const}$  entering from  $x = -\infty$  imply that  $G = -C$ , and the condition (3.112b) on  $y = 0+$  then leads to

$$-BF'(x) = Uf'_+(x). \quad (3.128)$$

The potential in region (2) is thus given by

$$\phi_+(x, y) = -\frac{U}{B}(f_+(x - By) - f_+(-a)), \quad (3.129a)$$

where we have subtracted an appropriate constant to make  $\phi$  continuous between regions (1) and (2). By a similar argument, the potential in region (5) is

$$\phi_-(x, y) = \frac{U}{B}(f_-(x + By) - f_-(-a)). \quad (3.129b)$$

Imposing continuity of  $\phi$  across the boundary of regions (2) and (3) gives  $\phi = C_1 = -U(f_+(a) - f_+(-a))/B$  in region (3). Similarly, imposing continuity of  $\phi$  across the boundary of regions (5) and (6) gives  $\phi = C_2 = U(f_-(a) - f_-(-a))/B$  in region (6). The resulting jump in the potential across the boundary of regions (3) and (6), *i.e.* across the wake, is equal to the circulation  $\Gamma = \phi(a, 0-) - \phi(a, 0+) = C_2 - C_1$ .

Finally, we can substitute (3.129) into (3.114) to calculate the lift on the wing. Assuming the wing is smooth at either end, we can set

$$f_+(-a) = f_-(-a) = 0 \quad (\text{without loss of generality}) \quad \text{and} \quad f_+(a) = f_-(a) = \lambda, \quad (3.130)$$

so that  $\lambda$  represents the difference between the heights of the two ends. Since the circulation  $\Gamma = C_2 - C_1 = 2\lambda U/B$ , the lift is found to be

$$L = -\frac{2\rho_0\lambda U^2}{\sqrt{M^2 - 1}}. \quad (3.131)$$

Thus the lift is positive if the rear of the wing is lower than the front, and zero if they are at the same height (as in figure 3.6 for example). Note again that the force experienced by the wing becomes large as the Mach number approaches 1.

## 4 Nonlinear waves

### 4.1 Introduction

In this section we present some *nonlinear* models for wave propagation, concentrating on two particular examples. The first is one-dimensional gas dynamics, which may be applied to the motion of gas in a tube. The second is shallow water theory, which describes tidal waves and long waves in rivers and canals. We will show that both problems may be modelled using the same system of partial differential equations.

Since these equations are nonlinear, none of the techniques presented in section 3 can be used to solve them. However, we show that certain quantities, known as *Riemann invariants*, are conserved along curves known as *characteristics*. This allows us to infer the solution in simple situations, such as the flow caused by the motion of a piston in a tube or due to a dam break.

We find that the solutions may become multivalued, so that (*e.g.*) the velocity appears to take two distinct values at a single position and time. This is a generic property of nonlinear hyperbolic partial differential equations, and a single-valued solution may be obtained by introducing *shock waves*, which will be discussed in section 5.

### 4.2 One-dimensional gas dynamics

#### Governing equations

Consider an inviscid fluid, for example gas in a tube, flowing in just one space dimension  $x$  and time  $t$ . If the body force is negligible, the velocity  $\mathbf{u} = u(x, t)\hat{e}_x$ , density  $\rho(x, t)$  and pressure  $p(x, t)$  satisfy the one-dimensional Euler equations

$$\frac{\partial \rho}{\partial t} + \frac{\partial}{\partial x}(\rho u) = 0, \quad (4.1)$$

$$\frac{\partial u}{\partial t} + u \frac{\partial u}{\partial x} = -\frac{1}{\rho} \frac{\partial p}{\partial x}. \quad (4.2)$$

Assuming the flow is *homentropic* (as shown in section 1, this is true if the entropy is initially uniform), we also have the equation of state

$$\frac{p}{\rho^\gamma} = \text{const} = \frac{p_0}{\rho_0^\gamma}. \quad (4.3)$$

If we define the *speed of sound*  $c$  by

$$c^2 = \frac{dp}{d\rho} = \frac{\gamma p_0 \rho^{\gamma-1}}{\rho_0^\gamma}, \quad (4.4)$$

then both  $\rho$  and  $p$  may be expressed in terms of  $c$ :

$$\rho = \left( \frac{\rho_0^\gamma}{\gamma p_0} \right)^{1/(\gamma-1)} c^{2/(\gamma-1)}, \quad p = \left( \frac{\rho_0^\gamma}{\gamma p_0} \right)^{1/(\gamma-1)} \frac{c^{2\gamma/(\gamma-1)}}{\gamma}. \quad (4.5)$$

Hence (4.2) may be turned into a system of two equations for  $u$  and  $c$ , namely

$$\frac{2}{\gamma-1} \left( \frac{\partial c}{\partial t} + u \frac{\partial c}{\partial x} \right) + c \frac{\partial u}{\partial x} = 0, \quad (4.6a)$$

$$\frac{\partial u}{\partial t} + u \frac{\partial u}{\partial x} + \frac{2c}{\gamma-1} \frac{\partial c}{\partial x} = 0. \quad (4.6b)$$

By adding and subtracting (4.6a) and (4.6b), we obtain

$$\frac{\partial}{\partial t} \left( u + \frac{2c}{\gamma-1} \right) + (u+c) \frac{\partial}{\partial x} \left( u + \frac{2c}{\gamma-1} \right) = 0, \quad (4.7a)$$

$$\frac{\partial}{\partial t} \left( u - \frac{2c}{\gamma-1} \right) + (u-c) \frac{\partial}{\partial x} \left( u - \frac{2c}{\gamma-1} \right) = 0, \quad (4.7b)$$

which can be combined to give

$$\left( \frac{\partial}{\partial t} + (u \pm c) \frac{\partial}{\partial x} \right) \left( u \pm \frac{2c}{\gamma-1} \right) = 0. \quad (4.8)$$

If we define the *characteristics* as curves in the  $(x, t)$  plane satisfying  $dx/dt = u \pm c$ , then (4.8) becomes

$$\frac{d}{dt} \left( u \pm \frac{2c}{\gamma-1} \right) = 0. \quad (4.9)$$

Hence

$$u \pm \frac{2c}{\gamma-1} \text{ is constant on curves satisfying } \frac{dx}{dt} = u \pm c. \quad (4.10)$$

The quantities  $u \pm 2c/(\gamma-1)$  which are conserved along characteristics are known as *Riemann invariants*. Although it is not possible to write down the general solution of (4.8), we can use the property (4.10) to infer the solution in simple cases, as we now illustrate.

### Example: flow due to a piston

Suppose that gas occupying the half-space  $x > 0$  starts at rest with  $c = c_0$ . Then a piston, starting at  $x = 0$ , is withdrawn such that its position at time  $t$  is  $x = s(t)$ , where  $s(0) = 0$  and  $\dot{s}(t) < 0$  for  $t > 0$ , using  $\dot{s}$  as shorthand for  $ds/dt$ . To model this situation, we apply the boundary and initial conditions

$$u = 0, \quad c = c_0 \quad \text{at } t = 0, \quad u = \dot{s}(t) \quad \text{at } x = s(t). \quad (4.11)$$

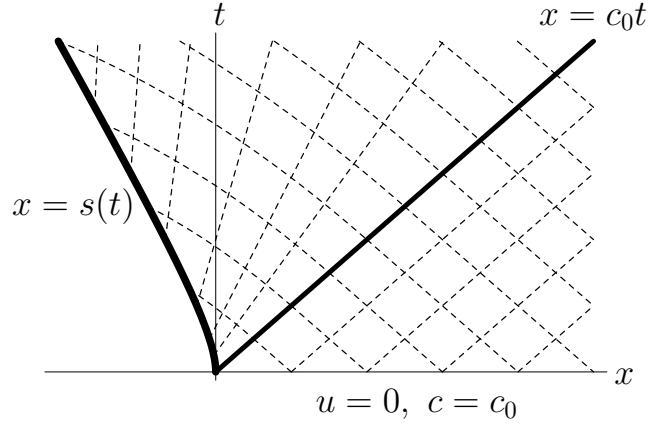

Figure 4.1: Sketch of the  $(x, t)$  plane for the piston withdrawal problem. The piston position is  $x = s(t)$  and the characteristics are shown as dashed lines.

The solution is best understood by sketching the  $(x, t)$  plane, as shown in figure 4.1, in which the characteristics are represented by dashed lines.

First consider the region penetrated by both families of characteristics starting from  $t = 0$ . On the *positive* characteristics  $\dot{x} = u + c$ ,  $u + 2c/(\gamma - 1)$  is conserved and therefore equal to its value at  $t = 0$ , that is

$$u + \frac{2c}{\gamma - 1} = \frac{2c_0}{\gamma - 1}. \quad (4.12a)$$

Similarly, on the *negative* characteristics  $\dot{x} = u - c$ , we have

$$u - \frac{2c}{\gamma - 1} = -\frac{2c_0}{\gamma - 1}. \quad (4.12b)$$

It follows from (4.12) that we must have  $u \equiv 0$  and  $c \equiv c_0$  wherever both sets of characteristics started from  $t = 0$ ,  $x > 0$ . The characteristics in this region are thus given by  $\dot{x} = \pm c_0$ , from which we can deduce that the region is bounded by the characteristic  $x = c_0 t$  and hence

$$u = 0, \quad c = c_0 \quad \text{in } x > c_0 t. \quad (4.13)$$

In  $x < c_0 t$ , we still have negative characteristics that started from  $t = 0$ , so the identity (4.12b) still holds. The positive characteristics, though, start from the piston  $x = s(t)$ , so we cannot use (4.12a). However, we know that  $u + 2c/(\gamma - 1)$  is conserved along each positive characteristic and, since  $u$  and  $c$  are also related by (4.12b), it follows that *both  $u$  and  $c$  are constant along each positive characteristic* (but different constants on each one). It follows that each positive characteristic has a constant slope  $u + c$  and, hence, that *the positive characteristics are straight lines*.

We can use these observations to construct the solution in  $x < c_0 t$  as follows. Consider the positive characteristic that starts at the point  $t = \tau$ ,  $x = s(\tau)$  on the piston. Since it is a straight line, it must have an equation of the form

$$x = s(\tau) + A(\tau)(t - \tau), \quad (4.14)$$



for some  $A(\tau)$ . On each such characteristics,  $u$  is constant and thus equal to its value  $\dot{s}(\tau)$  at the piston, and  $c$  may then be inferred from (4.12b). Finally, by using the fact that the slope of the positive characteristics is  $A = u + c$ , we end up with the solution in the parametric form

$$u = \dot{s}(\tau), \quad c = c_0 + \left(\frac{\gamma-1}{2}\right)\dot{s}(\tau), \quad x = s(\tau) + \left\{c_0 + \left(\frac{\gamma+1}{2}\right)\dot{s}(\tau)\right\}(t-\tau). \quad (4.15)$$

Recall that  $c$  is proportional to  $\rho^{(\gamma-1)/2}$  which must be nonnegative. We therefore deduce from (4.15) the inequality

$$-\dot{s}(\tau) \leq \frac{2c_0}{\gamma-1}. \quad (4.16)$$

If the withdrawal speed is ever faster than this, then the piston leaves the gas behind, and there is a region of vacuum near the piston. Suppose, for example, that the piston accelerates such that (4.16) is satisfied only until  $\tau = \tau_c$ . If so, then (4.15) holds for  $\tau \leq \tau_c$ , and is replaced by  $c = 0$  when  $\tau > \tau_c$ .

### Expansion fans

Only if the piston position  $s(t)$  takes a particularly simple form is it possible to eliminate  $\tau$  from (4.15) and thus obtain  $u$  and  $c$  explicitly. For example, suppose the piston is withdrawn at constant speed  $U$ , so that  $s = -Ut$  and (4.15) becomes

$$u = -U, \quad c = c_0 - \left(\frac{\gamma-1}{2}\right)U, \quad x = -U\tau + \left\{c_0 - \left(\frac{\gamma+1}{2}\right)U\right\}(t-\tau). \quad (4.17)$$

In this case we therefore find that  $u$  and  $c$  are both constant. Notice, though, that this solution is only valid in the region penetrated by positive characteristics starting from the piston. The first of these is at  $\tau = 0$ , so (4.17) tells us that

$$u = -U, \quad c = c_0 - \left(\frac{\gamma-1}{2}\right)U \quad \text{in} \quad x < \left\{c_0 - \left(\frac{\gamma+1}{2}\right)U\right\}t. \quad (4.18)$$

We also have the solution  $u = 0$  and  $c = c_0$  in  $x > c_0t$ , but there is a region between not penetrated by any positive characteristics either from the piston or from  $t = 0$ . The negative characteristics mean that (4.12b) is still satisfied in this region, and it follows as before that the positive characteristics are straight lines, along each of which both  $u$  and  $c$  are conserved. The only way to avoid them crossing  $x = c_0t$  or  $x = (c_0 - (\gamma+1)U/2)t$ , either of which would lead to a contradiction, the positive characteristics must be *straight lines through the origin*, as shown in figure 4.2. This structure, with the characteristics radiating out from the origin, is known as an *expansion fan*.

Since the positive characteristics have slope  $\dot{x} = u + c$ , their equation must be

$$x/t = u + c. \quad (4.19)$$

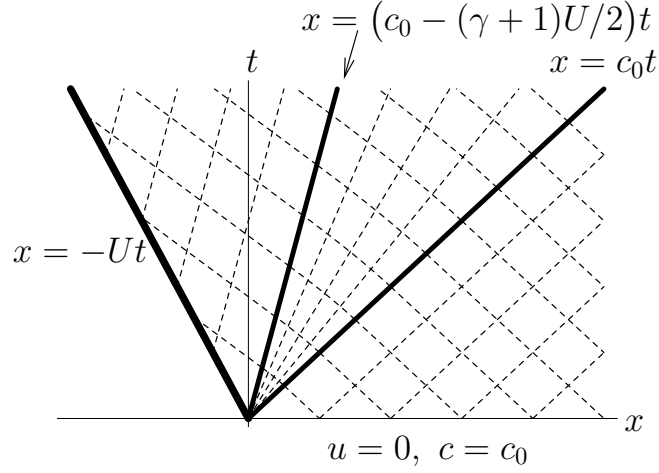

Figure 4.2: Sketch of the  $(x, t)$  plane for the piston withdrawal problem with  $s(t) = -Ut$ .

From this and (4.12b), we obtain both  $u$  and  $c$  in the fan region, namely

$$u = \frac{2(x/t - c_0)}{\gamma + 1}, \quad c = \frac{2c_0 + (\gamma - 1)x/t}{\gamma + 1}. \quad (4.20)$$

In summary, then, the solution for a piston being withdrawn at constant speed is

$$u = \begin{cases} -U & -U < \frac{x}{t} < c_0 - \frac{(\gamma + 1)U}{2}, \\ \frac{2}{\gamma + 1} \left( \frac{x}{t} - c_0 \right) & c_0 - \frac{(\gamma + 1)U}{2} < \frac{x}{t} < c_0, \\ 0 & \frac{x}{t} > c_0, \end{cases} \quad (4.21a)$$

$$c = \begin{cases} c_0 - \frac{(\gamma - 1)U}{2} & -U < \frac{x}{t} < c_0 - \frac{(\gamma + 1)U}{2}, \\ \frac{1}{\gamma + 1} \left( 2c_0 + (\gamma - 1)\frac{x}{t} \right) & c_0 - \frac{(\gamma + 1)U}{2} < \frac{x}{t} < c_0, \\ c_0 & \frac{x}{t} > c_0. \end{cases} \quad (4.21b)$$

If  $U > 2c_0/(\gamma - 1)$ , then (4.21) can no longer valid since it gives a negative value of  $c$ . In this case, the expansion fan stops where  $c$  reaches zero and there is a vacuum

thereafter, so (4.21) is modified to

$$u = \begin{cases} \text{undefined} & -U < \frac{x}{t} < -\frac{2c_0}{\gamma-1}, \\ \frac{2}{\gamma+1} \left( \frac{x}{t} - c_0 \right) & -\frac{2c_0}{\gamma-1} < \frac{x}{t} < c_0, \\ 0 & \frac{x}{t} > c_0, \end{cases} \quad (4.22a)$$

$$c = \begin{cases} 0 & -U < \frac{x}{t} < -\frac{2c_0}{\gamma-1}, \\ \frac{1}{\gamma+1} \left( 2c_0 + (\gamma-1) \frac{x}{t} \right) & -\frac{2c_0}{\gamma-1} < \frac{x}{t} < c_0, \\ c_0 & \frac{x}{t} > c_0. \end{cases} \quad (4.22b)$$

Here the gas expands freely, and the velocity of the piston no longer affects the solution.

### Simple waves

In all the cases analysed above, it is the fact that the Riemann invariant  $u - 2c/(\gamma - 1)$  is constant throughout the fluid that enables us to make analytical progress. Solutions in which one of the Riemann invariants is constant are called *simple waves*. The known Riemann invariant allows us to eliminate one unknown and thus obtain a first-order partial differential equation in just one variable. Here, if we use (4.12b) to write

$$c = c_0 + \left( \frac{\gamma-1}{2} \right) u \quad (4.23)$$

and substitute this expression for  $c$  into (4.7a), we obtain

$$\frac{\partial u}{\partial t} + \left( c_0 + \frac{(\gamma+1)u}{2} \right) \frac{\partial u}{\partial x} = 0. \quad (4.24)$$

This can be solved using the standard method of characteristics for first-order quasi-linear partial differential equations. The characteristic equations are

$$\frac{dx}{dt} = c_0 + \frac{(\gamma+1)u}{2}, \quad \frac{du}{dt} = 0, \quad (4.25)$$

which can be integrated to give

$$x - \left( c_0 + \frac{(\gamma+1)u}{2} \right) t = \text{const}, \quad u = \text{const}. \quad (4.26)$$

It follows that the general solution for  $u$  is

$$u = f \left( x - c_0 t - \frac{(\gamma+1)ut}{2} \right), \quad (4.27)$$

where  $f$  is an arbitrary function. All the solutions obtained above correspond to particular choices of the function  $f$ .

### 4.3 Shallow water theory

#### Governing equations

*Shallow water theory* is an approximate model describing long waves on a thin layer of fluid. We will derive the governing equations using *ad hoc* approximations, although they can also be obtained by systematic asymptotic methods.

Consider a layer of incompressible fluid flowing in two dimensions between a rigid base  $z = 0$  and a free surface  $z = h(x, t)$ . If the velocity field is  $\mathbf{u} = u(x, z, t)\hat{\mathbf{e}}_x + w(x, z, t)\hat{\mathbf{e}}_z$ , then the mass conservation equation reads

$$\frac{\partial u}{\partial x} + \frac{\partial w}{\partial z} = 0, \quad (4.28)$$

and the kinematic boundary conditions are

$$w = 0 \quad \text{on } z = 0, \quad w = \frac{\partial h}{\partial t} + u \frac{\partial h}{\partial x} \quad \text{on } z = h. \quad (4.29)$$

Integrating (4.28) with respect to  $z$  and applying the boundary conditions (4.29), we obtain

$$\frac{\partial h}{\partial t} + \frac{\partial h}{\partial x} u \Big|_{z=h} + \int_0^h \frac{\partial u}{\partial x} dz = 0, \quad (4.30)$$

or

$$\frac{\partial h}{\partial t} + \frac{\partial}{\partial x} (h\bar{u}) = 0, \quad (4.31a)$$

where

$$\bar{u} = \frac{1}{h} \int_0^h u dz \quad (4.31b)$$

is the *average horizontal velocity* in the fluid.

The two-dimensional Euler equations read

$$\frac{\partial u}{\partial t} + u \frac{\partial u}{\partial x} + w \frac{\partial u}{\partial z} = -\frac{1}{\rho} \frac{\partial p}{\partial x}, \quad (4.32a)$$

$$\frac{\partial w}{\partial t} + u \frac{\partial w}{\partial x} + w \frac{\partial w}{\partial z} = -\frac{1}{\rho} \frac{\partial p}{\partial z} - g, \quad (4.32b)$$

where  $p$  is the pressure,  $\rho$  is the (constant) density and  $g$  is the acceleration due to gravity. In shallow water theory, we assume that the flow is *almost* unidirectional, so that  $|w| \ll |u|$  and the left-hand side of (4.32b) may therefore be ignored. The pressure is thus purely *hydrostatic*; with  $p$  equal to atmospheric pressure  $p_a$  on  $z = h$ , we obtain

$$p = p_a + \rho g(h - z). \quad (4.33)$$

Assuming the flow is irrotational, we have  $\nabla \times \mathbf{u} = \mathbf{0}$ , or

$$\frac{\partial u}{\partial z} - \frac{\partial w}{\partial x} = 0. \quad (4.34)$$

Again assuming that  $|w| \ll |u|$ , we deduce that  $u$  is approximately independent of  $z$ , that is

$$u \approx u(x, t). \quad (4.35)$$

It follows that  $\bar{u} \approx u$  and so (4.31) becomes

$$\frac{\partial h}{\partial t} + u \frac{\partial h}{\partial x} + h \frac{\partial u}{\partial x} = 0, \quad (4.36a)$$

while the horizontal momentum equation, with  $p$  given by (4.33), reads

$$\frac{\partial u}{\partial t} + u \frac{\partial u}{\partial x} + g \frac{\partial h}{\partial x} = 0. \quad (4.36b)$$

The coupled nonlinear equations (4.36) for  $u$  and  $h$  are known as the *shallow water equations*, and they describe tidal waves and long waves in rivers and canals. Unlike the theory of Stokes waves, we have not assumed that the amplitude of the waves is small; typically, variations in the depth  $h$  are the same order as  $h$ . That is why the system (4.36) is nonlinear, while Stokes waves satisfy linear equations.

We define

$$c = \sqrt{gh} \quad (4.37)$$

which, recall from section 2, is the phase velocity of Stokes waves on a layer of depth  $h$ . In terms of  $c$ , (4.36) becomes

$$2 \left( \frac{\partial c}{\partial t} + u \frac{\partial c}{\partial x} \right) + c \frac{\partial u}{\partial x} = 0, \quad (4.38a)$$

$$\frac{\partial u}{\partial t} + u \frac{\partial u}{\partial x} + 2c \frac{\partial c}{\partial x} = 0, \quad (4.38b)$$

which are identical to the equations (4.6) of one-dimensional gas dynamics with  $\gamma = 2$ . The theory developed above for gas dynamics may therefore be applied directly to shallow water theory, by setting  $\gamma = 2$  and identifying  $c$  with  $\sqrt{gh}$ . In particular, the Riemann invariant statement (4.10) tells us that

$$u \pm 2\sqrt{gh} \text{ is constant on curves satisfying } \frac{dx}{dt} = u \pm \sqrt{gh}. \quad (4.39)$$

### Example: dam break

Suppose water of depth  $h_0$  is held in  $x > 0$  by a dam at  $x = 0$ . At time  $t = 0$ , the dam breaks, allowing the water to flow into  $x < 0$ . This situation is described by the solution

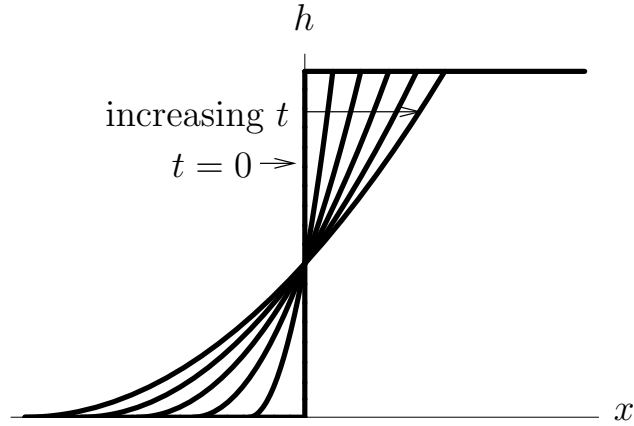

Figure 4.3: The evolution of the fluid height  $h(x, t)$  following a dam break.

(4.22), identifying  $c$  with  $\sqrt{gh}$  and setting  $\gamma = 2$ :

$$u = \begin{cases} \text{undefined} & \frac{x}{t} < -2\sqrt{gh_0}, \\ \frac{2}{3} \left( \frac{x}{t} - \sqrt{gh_0} \right) & -2\sqrt{gh_0} < \frac{x}{t} < \sqrt{gh_0}, \\ 0 & \frac{x}{t} > \sqrt{gh_0}, \end{cases} \quad (4.40a)$$

$$h = \begin{cases} 0 & \frac{x}{t} < -2\sqrt{gh_0}, \\ \frac{1}{9g} \left( 2\sqrt{gh_0} + \frac{x}{t} \right)^2 & -2\sqrt{gh_0} < \frac{x}{t} < \sqrt{gh_0}, \\ h_0 & \frac{x}{t} > \sqrt{gh_0}. \end{cases} \quad (4.40b)$$

We illustrate the evolution of the height  $h(x, t)$  in figure 4.3. The initial discontinuity at  $x = 0$  spreads into  $x < 0$  and  $x > 0$ , while the height at  $x = 0$  remains fixed at  $4h_0/9$  for all positive  $t$ .

## 4.4 Multi-valued solutions

### Example 1: simple wave

Suppose we have a simple wave, in which the Riemann invariant  $u - 2c/(\gamma - 1)$  is constant everywhere. As shown in section 4.2,  $u$  then satisfies a first-order quasilinear partial differential equation whose solution, subject to the initial condition  $u(x, 0) = f(x)$ , is

$$u = f \left( x - c_0 t - \frac{(\gamma + 1)ut}{2} \right). \quad (4.41)$$

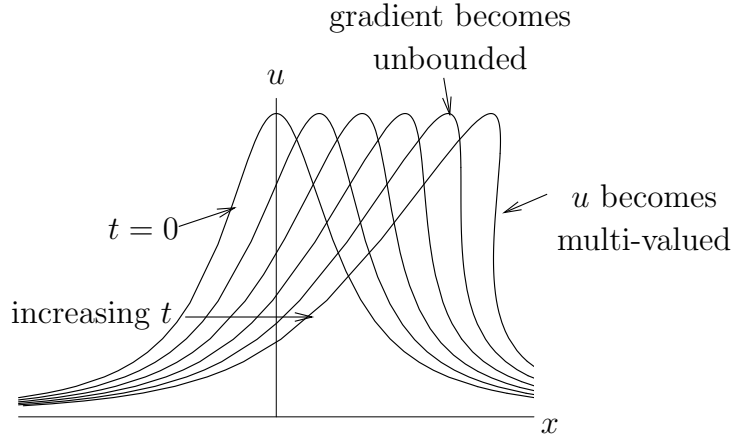

Figure 4.4: Schematic of a steepening simple wave.

This may be interpreted as a wave moving from left to right at speed  $c_0 + (\gamma + 1)u/2$ , so that *points on the wave where u is larger move faster*.

If we start with an initial localised wave like that shown in figure 4.4, then the wave *steepens* as  $t$  increases. By differentiating (4.41) with respect to  $x$ , we find that

$$\frac{\partial u}{\partial x} = \frac{f'(\xi)}{1 + (\gamma + 1)f'(\xi)t/2}, \quad \text{where } \xi = x - c_0t - \frac{(\gamma + 1)ut}{2}. \quad (4.42)$$

Thus  $|\partial u/\partial x|$  increases with  $t$  wherever  $f'$  is negative, and reaches infinity after a finite time

$$t_c = \min_{\xi} \left( -\frac{2}{(\gamma + 1)f'(\xi)} \right), \quad (4.43)$$

where the minimum is taken over all values of  $\xi$  such that  $f'(\xi) < 0$ . Thus, as shown in figure 4.4, the gradient of  $u$  is unbounded as  $t \rightarrow t_c$  and, for  $t > t_c$ ,  $u$  becomes a multiply-valued function of  $x$ .

This behaviour is physically unreasonable: the gas velocity must take a single, well-defined value at each point. In addition, we have assumed in deriving our equations of motion that  $u$  is a continuously differentiable function, which it clearly ceases to be at  $t = t_c$ . We will discuss the resolution of this problem in section 5.

### Example 2: piston moving into a tube

Another situation in which the solution becomes multi-valued is the piston problem analysed in section 4.2, where the piston is pushed into the tube rather than being withdrawn. Consider, for example, the case where the piston accelerates uniformly into the tube, so its position at time  $t$  is  $x = s(t) = at^2$ , and the parametric solution (4.15) becomes

$$u = 2a\tau, \quad c = c_0 + \frac{(\gamma - 1)u}{2}, \quad x = a\tau^2 + \{c_0 + (\gamma + 1)a\tau\}(t - \tau) \quad (4.44)$$

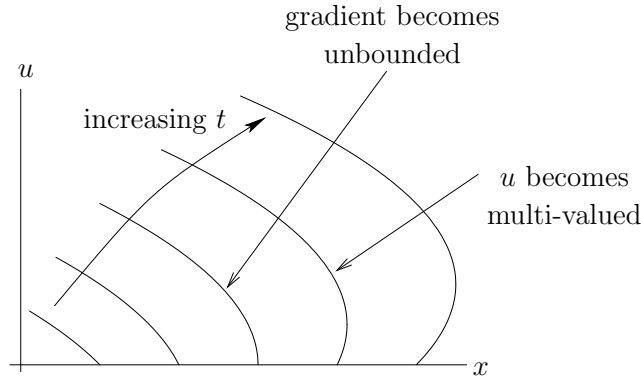

Figure 4.5: Evolution of the velocity profile  $u(x, t)$ , caused by the motion of a piston into a tube, versus  $x$  at increasing values of  $t$ .

in  $at^2 < x < c_0t$ .

By substituting for  $\tau$  from (4.44a) into (4.44c), we obtain an implicit equation for  $u$  as a function of  $x$  and  $t$ , namely

$$4a(c_0t - x) = \gamma u^2 + 2(c_0 - (\gamma + 1)at)u. \quad (4.45)$$

For each fixed time  $t$ , we can use this to plot  $u$  versus  $x$ , between  $u = 2at$  at  $x = at^2$  and  $u = 0$  at  $x = c_0t$ ; typical graphs as  $t$  is varied are shown in figure 4.5. Evidently  $x$  is a quadratic function of  $u$ , whose maximum is at

$$u = \frac{(\gamma + 1)at - c_0}{\gamma}, \quad x = c_0t + \frac{((\gamma + 1)at - c_0)^2}{4\gamma a}. \quad (4.46)$$

If  $t < c_0/(\gamma + 1)a$ , the maximum occurs in  $x > c_0t$  where  $u$  is negative, which is outside the region where the solution (4.44) applies. At the critical time

$$t = \frac{c_0}{(\gamma + 1)a}, \quad (4.47)$$

the minimum occurs at  $x = c_0t$  so that, as shown in figure 4.5, the gradient  $\partial u/\partial x$  becomes infinite at  $x = c_0t$ . For larger values of  $t$ ,  $u$  becomes a multi-valued function of  $x$ , which is physically impossible.

We can also understand this behaviour by examining the characteristics in the  $(x, t)$  plane. On each positive characteristic (corresponding to a particular fixed value of  $\tau$ ), (4.44) gives us unambiguous values of  $u$ ,  $c$  and  $x$  as functions of  $t$ . The solution becomes multi-valued when the positive characteristics start to cross, as illustrated in figure 4.6. When this happens, the same point in the  $(x, t)$  plane corresponds to different possible values of  $\tau$ .

With  $s(t) = at^2$ , it is clear the the positive characteristics from the piston must eventually intersect with  $x = c_0t$  (since the piston itself does at  $t = c_0/a$ ). From (4.44), we see that the characteristic with parameter  $\tau$  crosses  $x = c_0t$  when

$$a\tau^2 + \{c_0 + (\gamma + 1)a\tau\}(t - \tau) - c_0t = \tau((1 + \gamma)at - c_0 - \gamma a\tau) = 0. \quad (4.48)$$



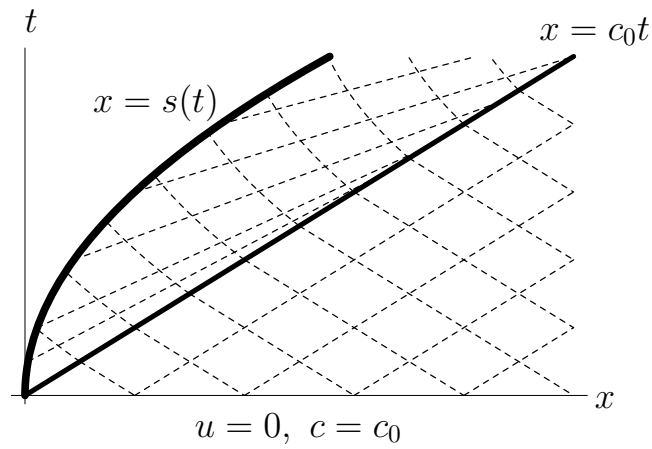

Figure 4.6: Characteristic diagram for a piston being pushed into a tube.

Discounting the root  $x = \tau = 0$ , we thus find that crossing occurs at

$$t = \frac{c_0 + \gamma a \tau}{(\gamma + 1)a}. \quad (4.49)$$

The earliest time at which the solution becomes multivalued is obtained in the limit  $\tau \rightarrow 0$ , which reproduces (4.47).

To maintain a single-valued solution, we must not allow the positive characteristics (or indeed the negative characteristics) to cross each other, and we will show how this can be achieved in the next section.

## 5 Shock waves

### 5.1 Introduction

In the previous section we discovered that the equations of one-dimensional gas dynamics admit solutions that become multivalued in finite time. This is unacceptable physically: it is impossible for a physical state variable such as velocity, pressure or density to take many different values at a single point. The solution becoming multivalued is heralded by a wave-steepening, in which the state variables start to vary rapidly with position; in figure 5.1(a) we show schematically a typical plot of the velocity  $u$  versus position  $x$  as time  $t$  increases.

In practice, behaviour like that shown in figure 5.1(b) is observed. Rather than become multivalued, the flow develops a singularity, known as a *shock wave* or simply a *shock*, across which the state variables (here the velocity) are effectively discontinuous. These shock waves also arise in shallow water theory (where they are known as *hydraulic jumps* or *bores*) and are to be expected from almost any nonlinear hyperbolic partial differential equations. Other well known examples include models for traffic flow, in which shock waves represent traffic jams.

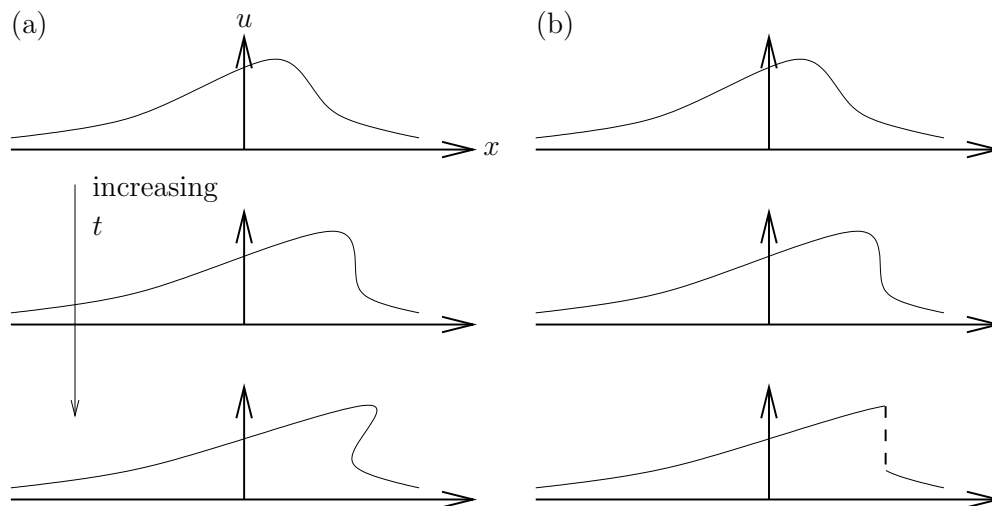

Figure 5.1: (a) Plot of the velocity  $u$  steepening as  $t$  increases and finally becoming multivalued. (b) Plot of an alternative scenario in which  $u$  becomes discontinuous.

In this section we will derive the so-called *Rankine–Hugoniot conditions* that must be satisfied across a shock if it is to conserve mass, momentum and energy. These will

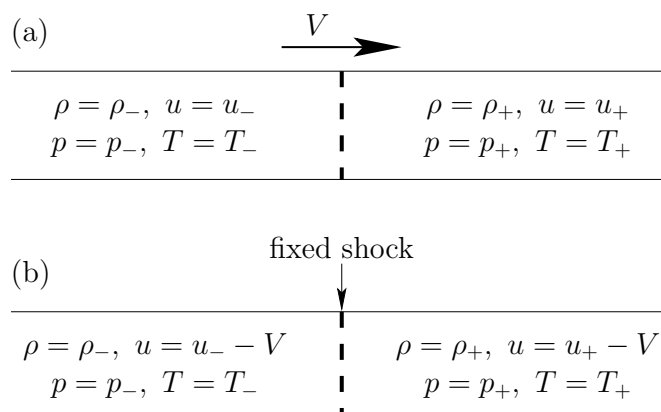

Figure 5.2: (a) Schematic of a shock moving in a tube at speed  $V$ . (b) The equivalent situation with a fixed shock.

allow us to describe physical situations like a shock wave caused by a piston in a tube or a bore moving into stationary water. We will also show how the Rankine–Hugoniot conditions fit into the more general theory of *weak solutions*.

## 5.2 One-dimensional gas dynamics

### Rankine–Hugoniot conditions

Suppose that  $\rho$ ,  $u$ ,  $p$  and  $T$  are discontinuous across a shock moving with speed  $V$ . As shown in figure 5.2(a), we denote the values to the left and right of the shock by  $-$  and  $+$  suffices, with the  $+$  side being the side on which  $x$  is greater. By transforming to a frame that moves with the shock, as shown in figure 5.2(b), we can equivalently study the problem of a stationary shock by modifying the velocities on either side according to

$$u_{\pm} \mapsto u_{\pm} - V. \quad (5.1)$$

We will therefore confine our attention to the case  $V = 0$  initially, and then use the transformation (5.1) to apply our results to a shock moving at arbitrary speed.

If  $V = 0$ , then mass enters the shock from the left at a rate  $\rho_- u_-$  (per unit cross-sectional area), and exits to the right at a rate  $\rho_+ u_+$ . Since mass cannot be created or destroyed within the shock, these must be equal to each other, that is

$$[\rho u]_-^+ = 0, \quad (5.2)$$

where  $[\cdot]_-^+$  denotes the jump in  $\cdot$  across the shock.

Next we consider conservation of momentum. In a time  $\delta t$ , a mass  $\rho_- u_- \delta t = \rho_+ u_+ \delta t$  crosses the shock from left to right (assuming  $u_{\pm}$  are positive). As it does so, its velocity changes from  $u_-$  to  $u_+$ , so its momentum changes from  $\rho_- u_-^2 \delta t$  to  $\rho_+ u_+^2 \delta t$ . This change in momentum must be accounted for the net pressure force acting on the fluid as it

passes through the shock, namely  $(p_- - p_+)$  (per unit cross-sectional area). Putting these together we obtain  $(p_- - p_+)\delta t = \rho_+ u_+^2 \delta t - \rho_- u_-^2 \delta t$ , or

$$[p + \rho u^2]_-^+ = 0. \quad (5.3)$$

Finally, we must ensure that energy is conserved across the shock. By an argument analogous to that applied to momentum above, the gas that crosses the shock in a time  $\delta t$  changes energy from  $\rho_- u_- e_- \delta t$  to  $\rho_+ u_+ e_+ \delta t$ , where

$$e = c_v T + \frac{u^2}{2} \quad (5.4)$$

is the energy per unit mass. The net work done by pressure on either side during the same time interval is  $(p_- u_- \delta t - p_+ u_+ \delta t)$  and, by equating these, we obtain

$$[\rho u e + u p]_-^+ = 0. \quad (5.5)$$

By using the ideal gas law

$$p = \rho R T = (\gamma - 1) \rho c_v T, \quad (5.6)$$

we can write (5.5) in the form

$$\left[ \rho u \left( \frac{u^2}{2} + \frac{\gamma p}{(\gamma - 1) \rho} \right) \right]_-^+ = 0. \quad (5.7)$$

Notice that this is satisfied identically if  $u_-$  (and therefore also  $u_+$ ) is zero. Such a solution, in which there is no flow across the shock is called a *contact discontinuity*. Otherwise, we can use the fact that  $\rho u$  is conserved across the shock to deduce from (5.7) that

$$\left[ \frac{u^2}{2} + \frac{\gamma p}{(\gamma - 1) \rho} \right]_-^+ = 0. \quad (5.8)$$

Equations (5.2), (5.3) and (5.8) are called *Rankine–Hugoniot conditions*, and they ensure that mass, momentum and energy are conserved across the shock.

### Rankine–Hugoniot conditions for a moving shock

Now as described above, we can apply the Rankine–Hugoniot conditions (5.2–5.8) to a shock moving with speed  $dx/dt = V$  by transforming  $u_{\pm}$  to  $u_{\pm} - V$ :

$$[\rho(u - V)]_-^+ = [p + \rho(u - V)^2]_-^+ = \left[ \frac{(u - V)^2}{2} + \frac{\gamma p}{(\gamma - 1) \rho} \right]_-^+ = 0. \quad (5.9)$$

The unknowns are  $\rho_{\pm}$ ,  $u_{\pm}$ ,  $p_{\pm}$  and  $V$ , totalling seven, and we have three Rankine–Hugoniot conditions, so in general we need to specify *four* of the state variables on either side of the shock. Here are some examples of typical situations.

### 1. Piston entry problem

For a piston being pushed into a tube at constant speed  $U$ , we anticipate that a shock moves ahead of the piston at constant speed  $V > U$ . In front of the shock, we specify the initial pressure, density and velocity,

$$p_+ = p_0, \quad \rho_+ = \rho_0, \quad u_+ = 0, \quad (5.10a)$$

and behind the shock the gas speed must equal the piston speed:

$$u_- = U. \quad (5.10b)$$

These give us the four equations required to supplement (5.9), and we thus end up with the three equations

$$\rho_-(U - V) = -\rho_0 V, \quad (5.11a)$$

$$p_- + \rho_-(U - V)^2 = p_0 + \rho_0 V^2, \quad (5.11b)$$

$$\frac{(U - V)^2}{2} + \frac{\gamma p_-}{(\gamma - 1)\rho_-} = \frac{V^2}{2} + \frac{\gamma p_0}{(\gamma - 1)\rho_0}, \quad (5.11c)$$

from which to determine  $\rho_-$ ,  $p_-$  and  $V$ . It is straightforward to show from (5.11) that the shock speed  $V$  is the positive root of

$$2V^2 - (\gamma + 1)UV - 2c_0^2 = 0, \quad (5.12)$$

where  $c_0^2 = \gamma p_0 / \rho_0$  as before.

### 2. Shock reflection

Suppose a shock moves at given initial speed  $V_0 > 0$  into gas at rest with initial density  $\rho_0$  and  $p_0$ . The velocity  $u_-$ , pressure  $p_-$ , and density  $\rho_-$  behind the shock are given by

$$\rho_-(u_- - V_0) = -\rho_0 V_0, \quad (5.13a)$$

$$p_- + \rho_-(u_- - V_0)^2 = p_0 + \rho_0 V_0^2, \quad (5.13b)$$

$$\frac{(u_- - V_0)^2}{2} + \frac{\gamma p_-}{(\gamma - 1)\rho_-} = \frac{V_0^2}{2} + \frac{\gamma p_0}{(\gamma - 1)\rho_0}. \quad (5.13c)$$

Suppose the shock hits a wall and is reflected, and then has speed  $-V_1 < 0$ . Now the variables  $u_-$ ,  $p_-$  and  $\rho_-$  in front of the reflected shock are given by (5.13), while behind the shock we have  $u_+ = 0$  and  $\rho_+$ ,  $p_+$  and  $V_1$  are to be determined from

$$\rho_-(u_- + V_1) = \rho_+ V_1, \quad (5.14a)$$

$$p_- + \rho_-(u_- + V_1)^2 = p_+ + \rho_+ V_1^2, \quad (5.14b)$$

$$\frac{(u_- + V_1)^2}{2} + \frac{\gamma p_-}{(\gamma - 1)\rho_-} = \frac{V_1^2}{2} + \frac{\gamma p_+}{(\gamma - 1)\rho_+}. \quad (5.14c)$$

After a straightforward but tedious algebraic manipulation, we find that the reflected speed is given by

$$V_1 = V_0 + \frac{(3 - \gamma)(V_0^2 - c_0^2)}{(\gamma + 1)V_0}. \quad (5.15)$$

### Shock relations and entropy

To understand the implications of the Rankine–Hugoniot conditions, we now manipulate them into a more convenient form. Defining the speed of sound

$$c^2 = \frac{\gamma p}{\rho} \quad (5.16)$$

as before, we find that (5.2), (5.3) and (5.8) may be written as

$$[\rho c M]_-^+ = [p(1 + \gamma M^2)]_-^+ = \left[ c^2 \left( 1 + \frac{(\gamma - 1)M^2}{2} \right) \right]_-^+ = 0, \quad (5.17)$$

where  $M = u/c$  is the Mach number, and we thus deduce the relations

$$\left( \frac{p_+}{p_-} \right) \left( \frac{\rho_+}{\rho_-} \right) = \frac{M_-^2}{M_+^2}, \quad (5.18a)$$

$$\frac{p_+}{p_-} = \frac{1 + \gamma M_-^2}{1 + \gamma M_+^2}, \quad (5.18b)$$

$$\left( \frac{p_+}{p_-} \right) \left( \frac{\rho_-}{\rho_+} \right) = \frac{2 + (\gamma - 1)M_-^2}{2 + (\gamma - 1)M_+^2}. \quad (5.18c)$$

From these we can eliminate the densities and pressures to obtain an equation involving just  $M_+$  and  $M_-$ , namely

$$\left( \frac{M_-^2}{M_+^2} \right) \left( \frac{2 + (\gamma - 1)M_-^2}{2 + (\gamma - 1)M_+^2} \right) = \left( \frac{1 + \gamma M_-^2}{1 + \gamma M_+^2} \right)^2, \quad (5.19)$$

which can be rearranged to

$$(M_+^2 - M_-^2) \{ 2\gamma M_+^2 M_-^2 - (\gamma - 1)(M_+^2 + M_-^2) - 2 \} = 0. \quad (5.20)$$

One solution is always  $M_+ = M_-$ , but then (5.18) implies that the pressure and density are also continuous. If there is a shock, we must therefore assume  $M_+ \neq M_-$ , in which case we can solve (5.20) for (say)  $M_+$ :

$$M_+^2 = \frac{2 + (\gamma - 1)M_-^2}{2\gamma M_-^2 - (\gamma - 1)}. \quad (5.21)$$

As shown in figure 5.3,  $M_-^2$  and  $M_+^2$  are both confined to the range  $((\gamma - 1)/2\gamma, \infty)$ ,

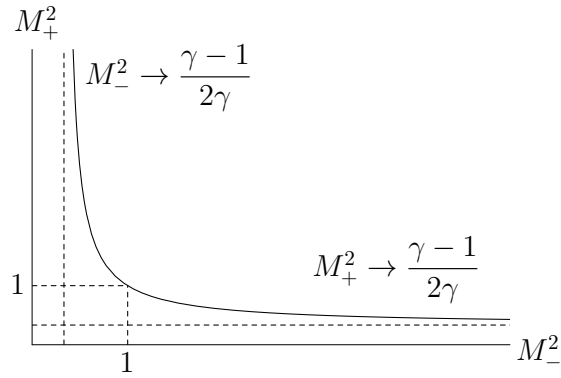

Figure 5.3: Graph of  $M_+^2$  versus  $M_-^2$ , as defined by (5.21).

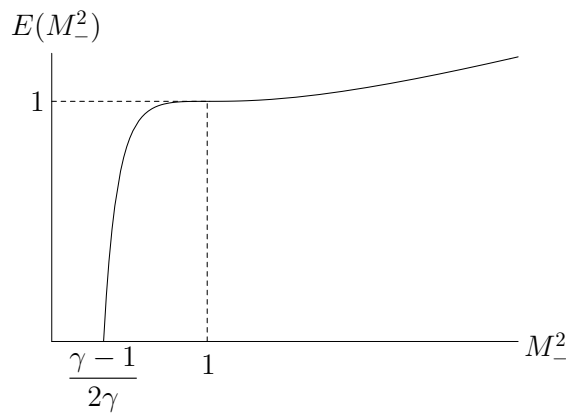

Figure 5.4: The function  $E(M_-^2)$  defined by (5.24).

and either  $M_-^2 > 1$ ,  $M_+^2 < 1$  or  $M_-^2 < 1$ ,  $M_+^2 > 1$ .

Recall from section 1 that the *entropy* is defined by

$$S = S_0 + c_v \log \left( \frac{p}{\rho^\gamma} \right). \quad (5.22)$$

From (5.18), we can deduce

$$\frac{p_+/\rho_+^\gamma}{p_-/\rho_-^\gamma} = \left( \frac{1 + \gamma M_-^2}{1 + \gamma M_+^2} \right)^{1+\gamma} \left( \frac{M_+^2}{M_-^2} \right)^\gamma, \quad (5.23)$$

or, using (5.21),

$$\exp \left( \frac{S_+ - S_-}{c_v} \right) = \left( \frac{2\gamma M_-^2 - (\gamma - 1)}{\gamma + 1} \right) \left( \frac{2 + (\gamma - 1)M_-^2}{(\gamma + 1)M_-^2} \right)^\gamma = E(M_-^2), \text{ say.} \quad (5.24)$$

A typical plot of the function  $E(M_-^2)$  is shown in figure 5.4. By differentiating (5.24) with respect to  $M_-^2$ , it may be shown that

$$E'(M_-^2) = \left( \frac{2\gamma(\gamma - 1)}{\gamma + 1} \right) \left( \frac{2 + (\gamma - 1)M_-^2}{(\gamma + 1)M_-^2} \right)^\gamma \frac{(M_-^2 - 1)^2}{M_-^2 (2 + (\gamma - 1)M_-^2)} \quad (5.25)$$

and hence that  $E(M_-^2)$  is an increasing function, with  $E = 0$  at the critical value  $M_-^2 = (\gamma - 1)/2\gamma$ ,  $E(1) = 1$  and  $E \rightarrow \infty$  as  $M_-^2 \rightarrow \infty$ . At  $M_-^2 = 1$ ,  $E$  has a point of inflection, with  $E(M_-^2) \sim 1 + O((M_-^2 - 1)^3)$  as  $M_-^2 \rightarrow 1$ .

At a shock, where  $M_-^2 \neq M_+^2$ , we must have  $M_-^2 \neq 1$ , and it follows that  $E(M_-^2) \neq 1$ , so *the entropy must be discontinuous across a shock*. Thus, when we write  $p = k\rho^\gamma$ , the constant  $k$  takes different values on either side of the shock. The Second Law of Thermodynamics tells us that the entropy must, if anything, *increase* as fluid crosses the shock, rather than decreasing. Hence, if the fluid travels from the  $-$  side to the  $+$  side, as illustrated in figure 5.2, then we require  $S_+ > S_-$ . It follows from (5.24) that  $M_-^2 > 1$  and from (5.21) that  $M_+^2 < 1$ , so *the flow changes from supersonic to subsonic as the gas crosses the shock*. Any shock that does not satisfy this condition is unphysical and could not be observed in practice.

Given that  $M_+^2 < 1 < M_-^2$ , it is straightforward to show from (5.18) that  $p_+/p_-$ ,  $\rho_+/\rho_-$  and  $p_+\rho_-/p_-\rho_+$  are all greater than 1. Thus the pressure, density and temperature must all increase as the gas passes through the shock. For this reason, a shock satisfying the condition of increasing entropy is said to be *compressive*.

For a shock moving at speed  $V$ , the same conclusions follow if  $M_\pm$  is defined as the Mach number *relative to the moving shock*, that is

$$M_\pm = \frac{u_\pm - V}{c_\pm}. \quad (5.26)$$

Consider, for example, a shock travelling into stationary gas with  $u_+ = 0$  and speed of sound  $c_+ = c_0$ . The entropy condition tells us that the upstream flow must be



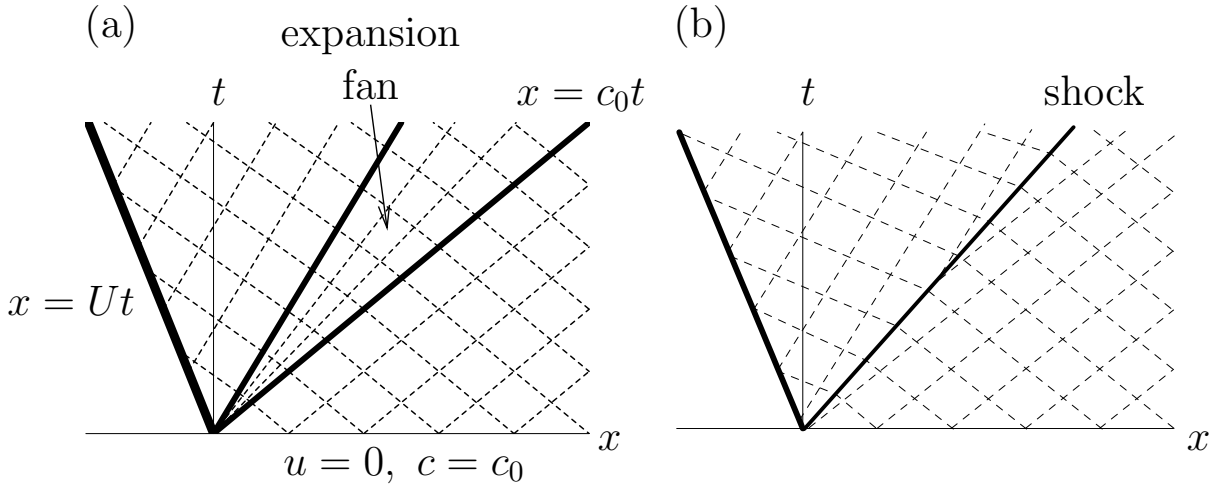

Figure 5.5: Characteristic diagrams for two possible solutions of the piston withdrawal problem: (a) solution with an expansion fan; (b) solution with a shock.

supersonic, that is  $M_+^2 = V^2/c_0^2 > 1$ , and hence the shock speed must be greater than  $c_0$ .

To illustrate the need for the entropy condition, we return briefly to example 1 from section 5.2, namely the shock caused by a piston impulsively moved at constant speed  $U$  into a stationary gas. The quadratic equation (5.12) leads to the following expression for the shock speed  $V$ :

$$V = \frac{(\gamma + 1)U + \sqrt{(\gamma + 1)^2 U^2 + 16c_0^2}}{4}. \quad (5.27)$$

The solution for the case where  $U$  is negative, so the piston is being pulled out rather than pushed in, was found previously in section 4. However, (5.27) also gives us a possible shock speed when  $U < 0$ , so in this case there are (at least) two possible solutions: one containing an expansion fan and one containing a shock, as illustrated in figure 5.5.

The entropy condition allows us to eliminate the shock solution and thus reassure ourselves that the expansion fan solution obtained in section 4 is correct. The upstream Mach number (relative to the shock) is given by

$$M_-^2 = \frac{V^2}{c_0^2} = 1 + \left(\frac{\gamma + 1}{2}\right) \frac{UV}{c_0^2}, \quad (5.28)$$

using (5.12). Hence  $M_-^2 < 1$  if  $U$  is negative, so this shock solution fails the entropy condition and is unphysical.

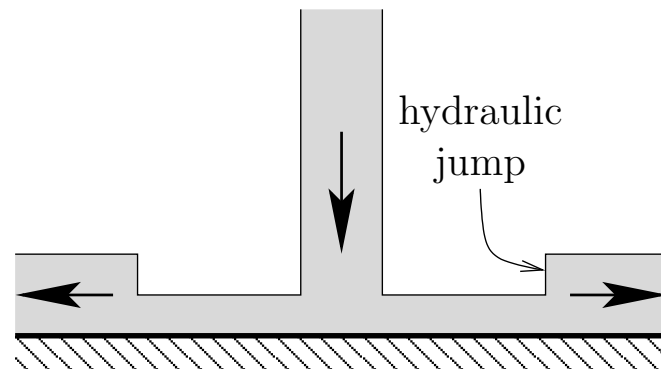

Figure 5.6: Schematic of the hydraulic jump formed when a jet of water hits a flat surface.

### 5.3 Shocks in shallow water theory

#### Rankine–Hugoniot conditions

Recall from section 4 the shallow water equations

$$\frac{\partial h}{\partial t} + u \frac{\partial h}{\partial x} + h \frac{\partial u}{\partial x} = 0, \quad \frac{\partial u}{\partial t} + u \frac{\partial u}{\partial x} + g \frac{\partial h}{\partial x} = 0, \quad (5.29)$$

governing the depth  $h(x, t)$  and velocity  $u(x, t)$  of a thin layer of fluid flowing over a flat base. Recall also that (5.29) are equivalent to the equations of one-dimensional gas dynamics, if  $c$  is identified with  $\sqrt{gh}$  and  $\gamma = 2$ . Therefore (5.29) also admit solutions which form discontinuities, known in the context of shallow water as *bores* or *hydraulic jumps*. Examples include the Severn Bore<sup>1</sup>, tidal waves and tsunamis, and the rapid jump observed when water from a tap impacts a flat surface, as illustrated in figure 5.6.

Suppose that  $u$  and  $h$  are discontinuous across a stationary hydraulic jump, as shown in figure 5.7. The rate at which fluid flows in from the left (per unit length in the  $y$ -direction) is  $h_- u_-$ . This must equal the rate at which fluid flows out from the right, which leads to

$$[hu]_-^+ = 0. \quad (5.30)$$

The net force acting to the left of the discontinuity (per unit length in the  $y$ -direction) is

$$\int_0^h (p_- - p_a) dz = \frac{\rho g h_-^2}{2}, \quad (5.31)$$

since in shallow water theory the pressure is assumed to be purely hydrostatic, that is

$$p = p_a + \rho g(h - z), \quad (5.32)$$

<sup>1</sup>see <http://www.severn-bore.co.uk/>

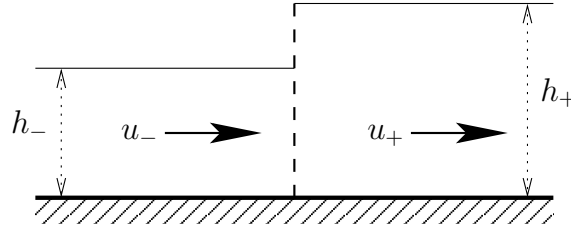

Figure 5.7: Schematic of a hydraulic jump.

where  $p_a$  is the constant atmospheric pressure. An expression analogous to (5.31) gives the force acting to the right. The fluid that crosses the jump in a time  $\delta t$  has mass  $\rho h_- u_- \delta t = \rho h_+ u_+ \delta t$  and its momentum (per unit length in the  $y$ -direction) changes from  $\rho h_- u_-^2 \delta t$  to  $\rho h_+ u_+^2 \delta t$ . By equating the rate of change of momentum to the applied force, we obtain

$$\rho h_+ u_+^2 - \rho h_- u_-^2 = \frac{\rho g h_-^2}{2} - \frac{\rho g h_+^2}{2}, \quad (5.33)$$

from which we deduce

$$\left[ hu^2 + \frac{gh^2}{2} \right]_-^+ = 0. \quad (5.34)$$

In section 4, we pointed out the analogy between the shallow water equations and the equations of one-dimensional gas dynamics. In particular, we showed that solutions of one-dimensional gas dynamics problems can be mapped onto solutions of shallow water theory by setting  $\gamma = 2$  and identifying  $c$  with  $\sqrt{gh}$ . However, the Rankine–Hugoniot conditions (5.30) and (5.34) are *not* the same as the conditions (5.2), (5.3) and (5.8) derived for gas dynamics. Thus a shallow water bore behaves differently from the corresponding shock in gas dynamics.

## Energy

The two Rankine–Hugoniot conditions (5.30) and (5.34) ensure that mass and momentum are conserved across a hydraulic jump. Now we consider energy conservation. The energy density  $e$  (per unit length in the  $y$ -direction) consists of the kinetic and potential energies:

$$e = \int_0^h \frac{\rho u^2}{2} + \rho g z \, dz = \frac{\rho h u^2}{2} + \frac{\rho g h^2}{2}. \quad (5.35)$$

The rate at which the energy increases as the fluid flows through the jump is thus

$$[ue]_-^+ = \left[ \frac{\rho h u^3}{2} + \frac{\rho g u h^2}{2} \right]_-^+. \quad (5.36)$$

The rate at which work is done by pressure is

$$\left[ \int_0^h p u \, dz \right]_-^+ = \left[ \frac{\rho g u h^2}{2} \right]_-^+ \quad (5.37)$$

so the net rate at which energy flows out of the jump is

$$Q = \left[ \frac{\rho h u^3}{2} + \rho g u h^2 \right]_{-}^{+} = \rho h u \left[ \frac{u^2}{2} + gh \right]_{-}^{+}, \quad (5.38)$$

using the fact that  $hu$  is conserved across the jump,

From (5.30) we have  $u_{-} = h_{+}u_{+}/h_{-}$ , so (5.34) may be written as

$$\left( h_{+} - \frac{h_{+}^2}{h_{-}} \right) u_{+}^2 = \frac{g}{2} (h_{-}^2 - h_{+}^2), \quad (5.39)$$

and, provided  $h_{-} \neq h_{+}$ , it follows that

$$u_{+}^2 = \frac{gh_{-}(h_{-} + h_{+})}{2h_{+}}, \quad u_{-}^2 = \frac{gh_{+}(h_{-} + h_{+})}{2h_{-}}. \quad (5.40)$$

Hence

$$\left[ \frac{u^2}{2} + gh \right]_{-}^{+} = \frac{g(h_{-}^2 - h_{+}^2)(h_{-} + h_{+})}{4h_{-}h_{+}} + g(h_{+} - h_{-}) = \frac{g(h_{-} - h_{+})^3}{4h_{+}h_{-}}, \quad (5.41)$$

and (5.38) may thus be written as

$$Q = (\rho h u) \frac{g(h_{-} - h_{+})^3}{4h_{+}h_{-}}. \quad (5.42)$$

Unless  $h_{-} = h_{+}$  (in which case there is no jump), we infer that energy is *not* conserved. If anything, we would expect energy to be lost as fluid crosses the jump, and in practice this occurs because of turbulence. We therefore must have  $Q < 0$ , which is analogous to the entropy condition for shocks in gas dynamics, and we deduce from (5.42) that  $u(h_{-} - h_{+}) < 0$ . In other words,  $h_{+} > h_{-}$  if  $u > 0$  or  $h_{-} > h_{+}$  if  $u < 0$ ; in either case, *the depth increases as the fluid passes through the jump* (as shown schematically in figure 5.6).

Assuming  $u_{\pm} > 0$ , so  $h_{+} > h_{-}$ , we can deduce from (5.40) the inequalities

$$\frac{u_{+}^2}{gh_{+}} < 1 < \frac{u_{-}^2}{gh_{-}}. \quad (5.43)$$

Recall from section 4 that  $\sqrt{gh} = c$  is identified with the wave speed in shallow water theory. The flow is described as *subcritical* if  $|u| < c$  and *supercritical* if  $|u| > c$ ; these are analogous to the descriptions subsonic and supersonic in gas dynamics. Hence (5.43) tells us that the fluid must change from supercritical to subcritical as it passes through the jump.

### Rankine–Hugoniot conditions for a moving bore

As observed in section 5.2, we can infer the Rankine–Hugoniot relations for a bore moving at speed  $V$  by transforming  $u_{\pm}$  to  $u_{\pm} - V$ , so that (5.30) and (5.34) become

$$[h(u - V)]_{-}^{+} = \left[ h(u - V)^2 + \frac{gh^2}{2} \right]_{-}^{+} = 0. \quad (5.44)$$

Now we have two equations for the five dependent variables  $h_{\pm}$ ,  $u_{\pm}$  and  $V$ , so another three conditions are needed to close the system. Here are some examples of typical situations.

#### 1. Bore moving into stationary water

If we specify the depth  $h_{\pm}$  on either side of the bore and that the water ahead of the bore is stationary ( $u_{+} = 0$ ), then (5.44) gives us

$$h_{-}(u_{-} - V) = -h_{+}V, \quad h_{-}(u_{-} - V)^2 + \frac{gh_{-}^2}{2} = h_{+}V^2 + \frac{gh_{+}^2}{2}, \quad (5.45)$$

to solve for  $u_{-}$  and  $V$ . By solving these simultaneous equations, it is straightforward to find that the shock speed  $V$  satisfies

$$V^2 = \frac{gh_{-}(h_{+} + h_{-})}{2h_{+}}. \quad (5.46)$$

Notice that the sign of  $V$  is not determined by the Rankine–Hugoniot condition, so it appears that the bore could move at speed  $V$  in either direction. We have to invoke the energy condition, which tells us that the height must increase as the fluid passes through the bore and, hence, that the bore must travel towards the shallower water.

#### 2. Bore reflection

If a bore travels at speed  $V_0$  towards stationary water with a given depth  $h_0$ , then we deduce from (5.44) that the velocity and depth behind the shock are given by

$$h_{-}(u_{-} - V_0) = -h_0V_0, \quad h_{-}(u_{-} - V_0)^2 + \frac{gh_{-}^2}{2} = h_0V_0^2 + \frac{gh_0^2}{2}. \quad (5.47)$$

If the bore is reflected by a stationary wall, then the depth  $h_{+}$  left behind the reflected bore and the reflected speed  $V_1$  satisfy

$$h_{-}(u_{-} + V_1) = h_{+}V_1, \quad h_{-}(u_{-} + V_1)^2 + \frac{gh_{-}^2}{2} = h_{+}V_1^2 + \frac{gh_{+}^2}{2}, \quad (5.48)$$

with  $h_{-}$  and  $u_{-}$  determined from (5.47).

## 5.4 Weak solutions

### Weak formulation

Now we briefly make the connection between our approach to shocks and the theory of so-called *weak solutions*. We have derived a set of partial differential equations describing (for example) gas dynamics which apply when the dependent variables ( $u$ ,  $\rho$ ,  $p$ , etc.) are continuously differentiable. When the dependent variables are discontinuous across a shock, we derived (starting again from physical conservation principles) Rankine–Hugoniot conditions governing the jumps in their values. A *weak formulation* is a compact statement of the problem that encompasses both differentiable solutions and discontinuous solutions.

Consider the conservation law

$$\frac{\partial \mathbf{P}}{\partial t} + \frac{\partial \mathbf{Q}}{\partial x} = \mathbf{0}, \quad (5.49)$$

where  $\mathbf{P}$  and  $\mathbf{Q}$  are differentiable vector functions of  $x$ ,  $t$  and  $\mathbf{u}(x, t)$ , which is the vector of dependent variables for which we are trying to solve. For example, the equations of one-dimensional gas dynamics and the shallow water equations may be stated in the form (5.49) with

$$\mathbf{u} = \begin{pmatrix} \rho \\ u \\ p \end{pmatrix}, \quad \mathbf{P} = \begin{pmatrix} \rho \\ \rho u \\ \rho u^2/2 + p/(\gamma - 1) \end{pmatrix}, \quad \mathbf{Q} = \begin{pmatrix} \rho u \\ \rho u^2 + p \\ \rho u^3/2 + \gamma p u/(\gamma - 1) \end{pmatrix} \quad (5.50a)$$

and

$$\mathbf{u} = \begin{pmatrix} h \\ u \end{pmatrix}, \quad \mathbf{P} = \begin{pmatrix} h \\ hu \end{pmatrix}, \quad \mathbf{Q} = \begin{pmatrix} uh \\ hu^2 + gh^2/2 \end{pmatrix} \quad (5.50b)$$

respectively.

We define a *weak solution* of (5.49) to be a function  $\mathbf{u}(x, t)$  that satisfies

$$\oint_C \mathbf{Q} dt - \mathbf{P} dx = \mathbf{0} \quad \text{for all piecewise-smooth simple closed curves } C. \quad (5.51)$$

We emphasise that there are other approaches to formulating weak versions of (5.49), for example using test functions, but (5.51) will do for our purposes. We should also point out that not all systems of partial differential equations may be written in the simple conservation form (5.49). However, physical models based on conservation principles almost inevitably give rise to systems equivalent to (5.49).

### Classical solutions

Suppose for the moment that  $\mathbf{u}(x, t)$  is continuously differentiable and satisfies (5.51); such a  $\mathbf{u}$  is called a *classical solution*. By applying Green's Theorem, we deduce from (5.51) that

$$\iint_S \left( \frac{\partial \mathbf{P}}{\partial t} + \frac{\partial \mathbf{Q}}{\partial x} \right) dx dt = \mathbf{0} \quad (5.52)$$

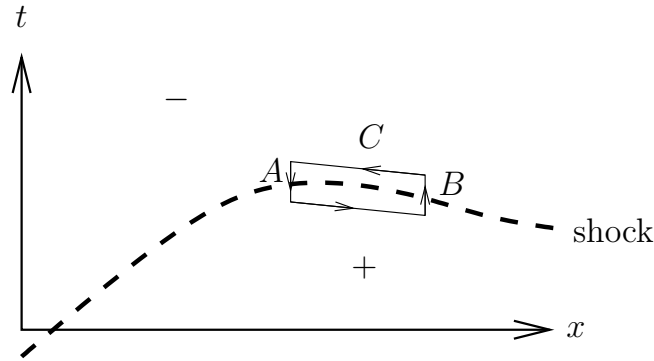

Figure 5.8: Schematic of a “pill box” contour  $C$  around a segment of a shock between two points  $A$  and  $B$ .

where  $S$  is *any* region of the  $(x, t)$  plane whose boundary  $C$  is a piecewise-smooth simple closed curve  $C$ . Since  $\partial \mathbf{P} / \partial t$  and  $\partial \mathbf{Q} / \partial x$  are continuous by assumption, it follows that  $\mathbf{u}$  must satisfy the conservation equation (5.49).

On the other hand, if  $\mathbf{u}$  is a differentiable solution of the conservation law (5.49) then we can again use Green’s Theorem to deduce that it must also satisfy the weak formulation (5.51). Hence, so far as classical solutions solutions are concerned, (5.49) and (5.51) are equivalent.

### Shocks

The advantage of the weak formulation over the partial differential equation (5.49) is that (5.51) makes sense if  $\mathbf{u}$  (and hence  $\mathbf{P}$  and  $\mathbf{Q}$ ) is not differentiable or even continuous. Suppose that a weak solution  $\mathbf{u}$  is continuously differentiable everywhere except on a shock, across which it is discontinuous. As shown in figure 5.8, the shock divides the  $(x, t)$  plane into two regions (labelled as before by  $+$  and  $-$ ) in each of which  $\mathbf{u}$  is continuously differentiable. It follows by the argument given above that  $\mathbf{u}$  must satisfy the conservation law (5.49) everywhere except on the shock.

Now let  $A$  and  $B$  be any two points on the shock and let  $C$  be a small “pill box” contour around the segment of the shock between  $A$  and  $B$ , as shown in figure 5.8. As  $C$  is shrunk towards the shock on either side, the edges near  $A$  and  $B$  shrink to zero length and we are left with

$$\oint_C \mathbf{Q} dt - \mathbf{P} dx = \int_A^B \mathbf{Q}_+ dt - \mathbf{P}_+ dx + \int_B^A \mathbf{Q}_- dt - \mathbf{P}_- dx = \mathbf{0}, \quad (5.53)$$

where the  $\pm$  subscript refers to  $\mathbf{P}$  and  $\mathbf{Q}$  evaluate on the  $+$  and  $-$  sides of the shock. We can write (5.53) as

$$\int_A^B [\mathbf{Q}]_-^+ dt - [\mathbf{P}]_-^+ dx = \int_A^B \{ [\mathbf{Q}]_-^+ - V [\mathbf{P}]_-^+ \} dt = \mathbf{0}, \quad (5.54)$$

where

$$V = \frac{dx}{dt} \quad (5.55)$$

is the shock speed as before. Since  $A$  and  $B$  are arbitrary, we deduce the *Rankine–Hugoniot conditions*

$$[\mathbf{Q}]_-^+ = V[\mathbf{P}]_-^+ \quad (5.56)$$

which must be satisfied across the shock.

### Example: one-dimensional gas dynamics

Now we verify that, for one-dimensional gas dynamics, the Rankine–Hugoniot conditions (5.56) derived via a weak formulation are equivalent to the conditions (5.9) obtained previously from first principles. With  $\mathbf{P}$  and  $\mathbf{Q}$  given by (5.50a), we can write (5.56) as

$$V = \frac{[\rho u]_-^+}{[\rho]_-^+} = \frac{[\rho u^2 + p]_-^+}{[\rho u]_-^+} = \frac{[\rho u^3/2 + \gamma p u/(\gamma - 1)]_-^+}{[\rho u^2/2 + p/(\gamma - 1)]_-^+}. \quad (5.57)$$

The first of these is clearly equivalent to the first of (5.9). The second relation in (5.57) may be rearranged to

$$0 = [\rho u(u - V) + p]_-^+ = \rho_-(u_- - V)[u]_-^+ + [p]_-^+, \quad (5.58)$$

using the fact that  $\rho(u - V)$  is conserved across the shock. Since  $[V]_-^+ = 0$ , we deduce that

$$0 = \rho_-(u_- - V)[(u - V)]_-^+ + [p]_-^+ = [\rho(u - V)^2 + p]_-^+, \quad (5.59)$$

which reproduces the second relation in (5.9).

From the final relation in (5.57), we obtain

$$0 = \left[ \frac{\rho u^2(u - V)}{2} + \frac{\gamma p u}{\gamma - 1} - \frac{pV}{\gamma - 1} \right] = \left[ \frac{\rho u^2(u - V)}{2} + \frac{\gamma p(u - V)}{\gamma - 1} + pV \right]_-^+, \quad (5.60)$$

or, by using (5.59) to evaluate  $[p]_-^+$ ,

$$\left[ \rho(u - V) \left( \frac{u^2}{2} - uV + V^2 + \frac{\gamma p}{(\gamma - 1)\rho} \right) \right]_-^+ = 0. \quad (5.61)$$

Now,  $\rho(u - V)$  is conserved and nonzero, assuming that our curve is a shock, not a contact discontinuity. By using the fact that  $[V^2]_-^+ = 0$ , we can thus deduce that

$$\left[ \frac{(u - V)^2}{2} + \frac{\gamma p}{(\gamma - 1)\rho} \right]_-^+ = 0, \quad (5.62)$$

which reproduces (5.9).



**Example: shallow water theory**

Next we confirm that the weak formulation of the shallow water equations yields Rankine–Hugoniot conditions equivalent to (5.44). With  $\mathbf{P}$  and  $\mathbf{Q}$  given by (5.50b), we deduce from (5.56) the equations

$$V = \frac{[hu]_-^+}{[h]_-^+} = \frac{[hu^2 + gh^2/2]_-^+}{[hu]_-^+}, \quad (5.63)$$

the first of which is clearly equivalent to (5.44). The second relation in (5.63) may be rearranged to

$$0 = \left[ hu(u - V) + \frac{gh^2}{2} \right]_-^+ = h_-(u_- - V)[u]_-^+ + \left[ \frac{gh^2}{2} \right]_-^+, \quad (5.64)$$

using the fact that  $h(u - V)$  is conserved across the shock. Since  $[V]_-^+ = 0$ , we can replace  $[u]_-^+$  with  $[u - V]_-^+$  and thus obtain

$$\left[ h(u - V)^2 + \frac{gh^2}{2} \right]_-^+ = 0, \quad (5.65)$$

which is identical to the second equation in (5.44).

**Nonuniqueness of conservation laws**

One conceptual difficulty with the weak formulation approach described above is that there may be several different ways of writing the same system of equations in conservation form. For example, the shallow water equations may be written in conservation form as

$$\frac{\partial h}{\partial t} + \frac{\partial}{\partial x}(uh) = 0, \quad \frac{\partial}{\partial t}(hu) + \frac{\partial}{\partial x} \left( hu^2 + \frac{gh^2}{2} \right) = 0, \quad (5.66)$$

or as

$$\frac{\partial h}{\partial t} + \frac{\partial}{\partial x}(uh) = 0, \quad \frac{\partial u}{\partial t} + \frac{\partial}{\partial x} \left( \frac{u^2}{2} + gh \right) = 0, \quad (5.67)$$

or in many other ways. Different choices of conservation law lead to different Rankine–Hugoniot conditions; for example, (5.66) corresponds to the Rankine–Hugoniot conditions (5.63), while (5.67) gives rise to

$$V = \frac{[hu]_-^+}{[h]_-^+} = \frac{[u^2/2 + gh]_-^+}{[u]_-^+}. \quad (5.68)$$

So, by putting the same equations into a different conservation form, we obtain different shock relations and hence different weak solutions (although all classical solutions will be the same).

To avoid this difficulty, we must choose functions  $\mathbf{P}$  and  $\mathbf{Q}$  that correspond to the real physical quantities that we wish the system to conserve. In (5.66a), for example,  $h$  and  $(uh)$  represent the mass density and mass flux, and the weak formulation of this conservation law ensures that mass of fluid is conserved across any shock. Similarly, in (5.66b),  $hu$  is proportional to the momentum density, while  $(hu^2 + gh^2/2)$  represents the momentum flux and the pressure force. Hence the weak version of (5.66b) conserves momentum across any shocks. It may be shown that (5.67b) represents conservation of *energy*, and weak solutions of (5.67) give rise to shocks that conserve mass and energy rather than mass and momentum.

### Nonuniqueness of weak solutions

Once we have chosen a particular conservation form (that is a particular choice of the functions  $\mathbf{P}$  and  $\mathbf{Q}$ ) for a system of equations, the Rankine–Hugoniot conditions satisfied across a shock are given uniquely by (5.56). Nevertheless, the weak solution of the problem may still be nonunique. We have already encountered this difficulty in section 5.3, when we showed that the direction of propagation of a bore could not be determined from the Rankine–Hugoniot conditions. In that case, we managed to select a direction by invoking the condition that the bore must dissipate energy rather than producing it.

In general, it may be shown that the weak formulation (5.51) has a unique solution when supplemented by an appropriate *entropy condition*. For a shallow water bore, this condition says that the depth must increase as fluid crosses the bore; in gas dynamics the entropy condition tells us that the fluid must change from supersonic to subsonic as it crosses the shock.

## 5.5 Two-dimensional steady shocks

### Rankine–Hugoniot conditions

First we consider a plane shock aligned with the  $y$ -axis, as shown schematically in figure 5.9. As usual, the values of the dependent variables on either side of the shock are denoted by  $\pm$  subscripts. If mass is to be conserved, the rate at which fluid flows in from the left must equal the rate at which it flows out from the right, which leads to the condition

$$[\rho u]_{-}^{+} = 0. \quad (5.69)$$

Now, the mass  $\rho u \delta t$  that passes through the shock in a time  $\delta t$  changes momentum from  $\rho_{-} u_{-} \delta t (u_{-}, v_{-})$  to  $\rho_{+} u_{+} \delta t (u_{+}, v_{+})$ . The rate of change of momentum must be equal to the net force acting on the shock, namely  $(p_{-} - p_{+}) \hat{e}_x$ , which leads to the condition

$$\left[ \rho u \begin{pmatrix} u \\ v \end{pmatrix} \right]_{-}^{+} = -[p]_{-}^{+} \begin{pmatrix} 1 \\ 0 \end{pmatrix}. \quad (5.70)$$

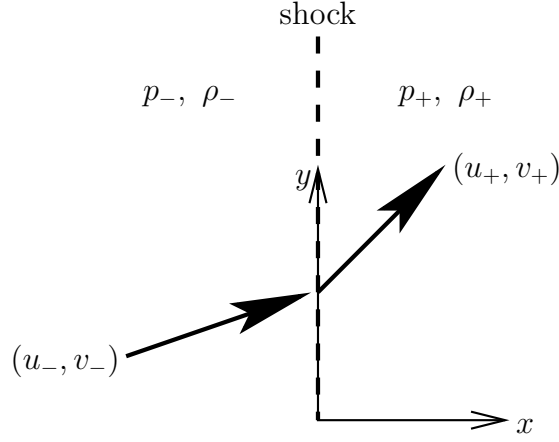
Figure 5.9: Schematic of two-dimensional flow through a shock along the  $y$ -axis.

From the first component we obtain

$$[p + \rho u^2]_{-}^{+} = 0, \quad (5.71)$$

while the second component of (5.70) may be written as  $(\rho u)[v]_{-}^{+} = 0$ , since  $\rho u$  is conserved across the shock. For a shock, as opposed to a contact discontinuity,  $(\rho u)$  is nonzero, and we deduce that

$$[v]_{-}^{+} = 0. \quad (5.72)$$

In a similar way, the mass crossing in time  $\delta t$  changes its energy from  $\rho_- u_- e_- \delta t$  to  $\rho_+ u_+ e_+ \delta t$ , where

$$e = \frac{u^2 + v^2}{2} + c_v T = \frac{u^2 + v^2}{2} + \frac{p}{(\gamma - 1)\rho} \quad (5.73)$$

is the energy density. This change in energy must be equal to the work done by pressure, and we deduce that

$$\left[ \rho u \left( \frac{u^2 + v^2}{2} + \frac{p}{(\gamma - 1)\rho} \right) \right]_{-}^{+} = -[pu]_{-}^{+}. \quad (5.74)$$

Since  $\rho u$  is conserved (and assumed nonzero), this may be simplified to

$$\left[ \frac{u^2}{2} + \frac{\gamma p}{(\gamma - 1)\rho} \right]_{-}^{+} = 0, \quad (5.75)$$

where we have also used (5.72).

In summary, we have shown that the *tangential* velocity  $v$  is conserved across a shock, while  $\rho$ ,  $p$  and the *normal* velocity  $u$  satisfy the Rankine–Hugoniot conditions (5.69), (5.71) and (5.75) which are identical to the conditions derived in section 5.2 for a stationary one-dimensional shock. In other words, we can view the two-dimensional

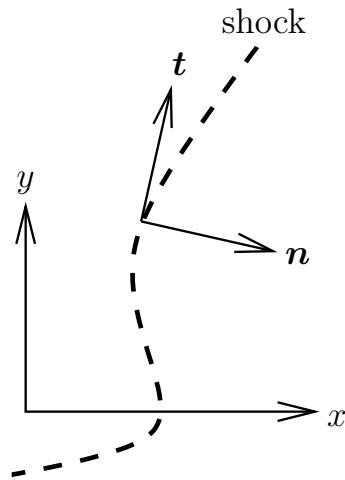

Figure 5.10: Schematic of a curved shock with local axes in the normal and tangential directions.

shock illustrated in figure 5.9 as equivalent to a one-dimensional shock with a superimposed tangential velocity. The entropy condition derived previously for one-dimensional shocks may thus be applied directly here, and tells us that the flow must change from supersonic to subsonic as it crosses the shock. In particular, if the flow is from  $-$  to  $+$ , then  $u_+ < u_-$  while  $v_+ = v_-$ , which implies that the flow is deflected *towards* the shock, as indicated in figure 5.9.

The conditions derived above may be applied to an arbitrary steady shock in two dimensions by adopting local axes parallel to the unit normal  $\mathbf{n}$  and tangent  $\mathbf{t}$ , as shown in figure 5.10. Thus we can identify  $u$  with the normal velocity  $u_n = \mathbf{u} \cdot \mathbf{n}$  and  $v$  with the tangential velocity  $u_t = \mathbf{u} \cdot \mathbf{t}$  and write the Rankine–Hugoniot conditions as

$$[\rho u_n]_-^+ = [p + \rho u_n^2]_-^+ = [u_t]_-^+ = \left[ \frac{u_n^2}{2} + \frac{\gamma p}{(\gamma - 1)\rho} \right]_-^+ = 0. \quad (5.76)$$

### Weak formulation

It is worth pointing out that the Rankine–Hugoniot conditions (5.76) for a curved shock may also be obtained from the weak formulation of the problem. The equations describ-

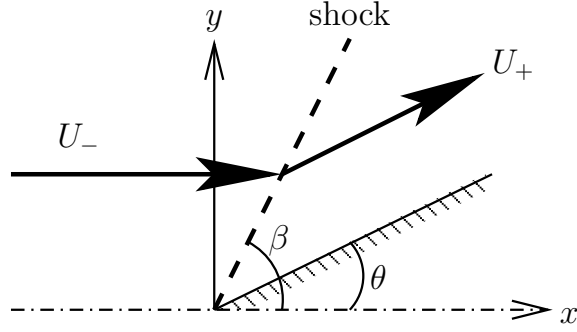

Figure 5.11: Supersonic flow past a wedge of angle  $\theta$ , with a shock making an angle  $\beta$  with the flow.

ing steady gas flow in two dimensions may be written in conservation form as

$$\frac{\partial}{\partial x}(\rho u) + \frac{\partial}{\partial y}(\rho v) = 0, \quad (5.77a)$$

$$\frac{\partial}{\partial x}(\rho u^2 + p) + \frac{\partial}{\partial y}(\rho uv) = 0, \quad (5.77b)$$

$$\frac{\partial}{\partial x}(\rho uv) + \frac{\partial}{\partial y}(\rho v^2 + p) = 0, \quad (5.77c)$$

$$\frac{\partial}{\partial x}(\rho ue + pu) + \frac{\partial}{\partial y}(\rho ve + pv) = 0, \quad (5.77d)$$

where the internal energy density  $e$  is given by (5.73) as before. The equations in (5.77) represent successively conservation of mass, momentum in the  $x$ - and  $y$ -directions and energy.

By following the approach adopted in section 5.4, we can infer directly from (5.77) the Rankine–Hugoniot conditions satisfied across a shock whose slope is  $dy/dx$ :

$$\frac{dy}{dx} = \frac{[\rho v]_-^+}{[\rho u]_-^+} = \frac{[\rho uv]_-^+}{[\rho u^2 + p]_-^+} = \frac{[\rho v^2 + p]_-^+}{[\rho uv]_-^+} = \frac{[(\rho e + p)v]_-^+}{[(\rho e + p)u]_-^+}. \quad (5.78)$$

If we let  $\theta$  denote the angle made by the shock with the  $x$ -axis at any point, then

$$\tan \theta = \frac{dy}{dx}, \quad \mathbf{t} = \begin{pmatrix} \cos \theta \\ \sin \theta \end{pmatrix}, \quad \mathbf{n} = \begin{pmatrix} \sin \theta \\ -\cos \theta \end{pmatrix}. \quad (5.79)$$

It is thus straightforward to manipulate (5.78) into the form (5.76).

### Example: flow past a wedge

The theory developed above may be applied to supersonic flow past a wedge, as illustrated in figure 5.11. We consider uniform flow with velocity  $U_-$  incident on a wedge making an angle  $\theta$  with the flow. (We only consider the upper half-plane; a similar flow

in the lower-half plane is obtained by reflection). By inserting a linear oblique shock making an angle  $\beta$  (which is to be determined) with the flow, we aim to deflect the incoming stream through the required angle  $\theta$ .

The Rankine–Hugoniot conditions for this situation are given by (5.76), with

$$u_{n-} = U_- \sin \beta, \quad u_{n+} = U_+ \sin(\beta - \theta), \quad u_{t-} = U_- \cos \beta, \quad u_{t+} = U_+ \cos(\beta - \theta), \quad (5.80)$$

and hence

$$U_- \cos \beta = U_+ \cos(\beta - \theta), \quad (5.81a)$$

$$\rho_- U_- \sin \beta = \rho_+ U_+ \sin(\beta - \theta), \quad (5.81b)$$

$$p_- + \rho_- U_-^2 \sin^2 \beta = p_+ + \rho_+ U_+^2 \sin^2(\beta - \theta), \quad (5.81c)$$

$$\frac{U_-^2 \sin^2 \beta}{2} + \frac{\gamma p_-}{(\gamma - 1)\rho_-} = \frac{U_+^2 \sin^2(\beta - \theta)}{2} + \frac{\gamma p_+}{(\gamma - 1)\rho_+}. \quad (5.81d)$$

Given the upstream velocity  $U_-$ , pressure  $p_-$  and density  $\rho_-$ , and the wedge angle  $\theta$ , (5.81) gives us four equations for  $U_+$ ,  $p_+$ ,  $\rho_+$  and the shock angle  $\beta$ .

Recall that (5.81b–d) are equivalent to the Rankine–Hugoniot conditions (5.2), (5.3) and (5.8) for a stationary one-dimensional shock, if we identify  $u_-$  with  $U_- \sin \beta$  and  $u_+$  with  $U_+ \sin(\beta - \theta)$ . We can therefore read off from (5.21) the following relation between the up- and downstream Mach numbers:

$$M_+^2 \sin^2(\beta - \theta) = \frac{2 + (\gamma - 1)M_-^2 \sin^2 \beta}{2\gamma M_-^2 \sin^2 \beta - (\gamma - 1)}. \quad (5.82)$$

From (5.18) and (5.81) we deduce two equations for the density ratio,

$$\frac{\rho_+}{\rho_-} = \frac{\tan \beta}{\tan(\beta - \theta)} = \frac{M_-^2 \sin^2 \beta}{M_+^2 \sin^2(\beta - \theta)} \frac{1 + \gamma M_+^2 \sin^2(\beta - \theta)}{1 + \gamma M_-^2 \sin^2 \beta} \quad (5.83)$$

and, by substituting for  $M_+^2 \sin^2(\beta - \theta)$  from (5.82), we obtain the equation

$$\frac{\tan \beta}{\tan(\beta - \theta)} = \frac{(\gamma + 1)M_-^2 \sin^2 \beta}{2 + (\gamma - 1)M_-^2 \sin^2 \beta}. \quad (5.84)$$

Given the incoming Mach number  $M_-$  and the wedge angle  $\theta$ , we can in principle solve (5.84) for the shock angle  $\beta$ .

To understand the implications of (5.84), we solve it for  $\tan \theta$ :

$$\tan \theta = \frac{2((M_-^2 - 1)\tan^2 \beta - 1)}{\tan \beta((2 + (\gamma - 1)M_-^2)\tan^2 \beta + 2 + (\gamma + 1)M_-^2)}. \quad (5.85)$$

A typical plot of  $\tan \theta$  versus  $\tan \beta$  is shown in figure 5.12. Clearly  $\tan \theta = 0$  when  $\tan \beta = (M_-^2 - 1)^{-1/2}$ , and this implies that

$$\sin \beta = \frac{1}{M_-}. \quad (5.86)$$

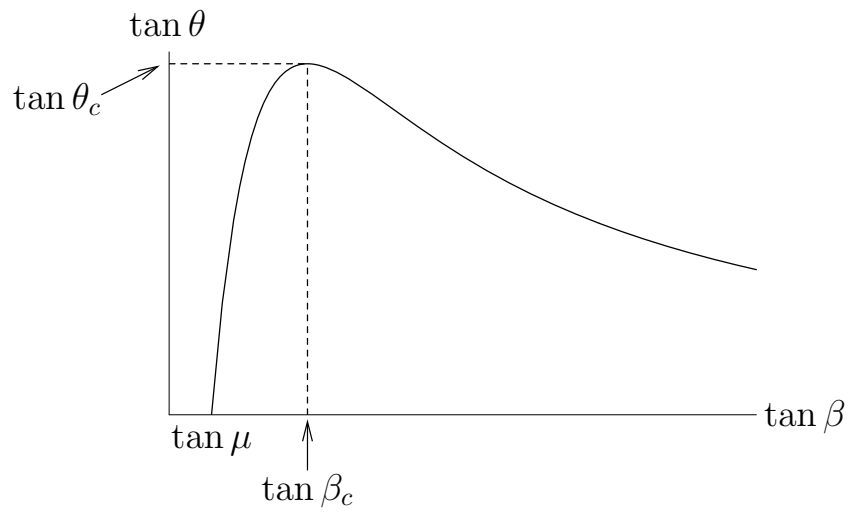

Figure 5.12: A plot of wedge slope  $\tan \theta$  versus shock slope  $\tan \beta$  as given by (5.85).

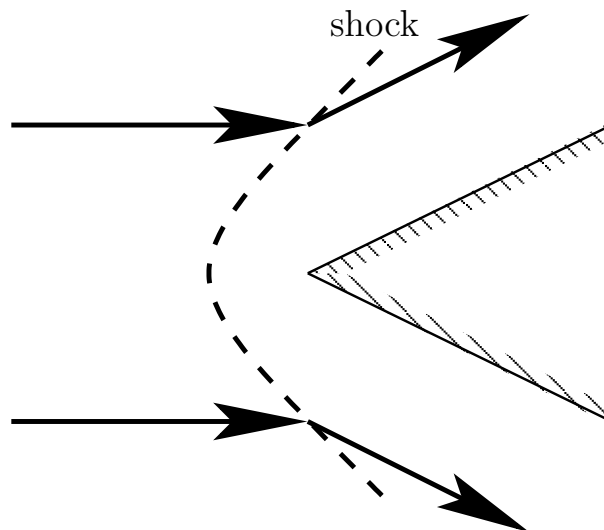

Figure 5.13: Schematic of supersonic flow past a wedge with angle greater than the critical angle.

Hence, as the wedge angle approaches zero,  $\beta$  approaches the *Mach angle*  $\mu$  defined in section 2.

For any fixed values of  $\gamma$  and  $M_-^2 > 1$ , the right-hand side of (5.85), considered as a function of  $\tan \beta$ , increases to a positive maximum before decaying towards zero, as shown in figure 5.12. Hence there is a maximum possible wedge angle  $\theta_c$ , above which no solution of the form illustrated in figure 5.11 exists. For wedge angles greater than  $\theta_c$  (or indeed for supersonic flow past a blunt obstacle), it is observed experimentally that a shock forms *upstream* of the obstacle, as indicated in figure 5.13. This surprising result appears to violate causality: how does the obstacle manage to influence the flow upstream of itself?

It is straightforward, by differentiating (5.85) with respect to  $M_-^2$ , to show that  $\tan \theta$  is an increasing function of  $M_-^2$ . Thus the maximum possible wedge angle (over all possible values of  $\beta$  and  $M_-$ ) is obtained in the *hypersonic* limit  $M_- \rightarrow \infty$ . In this limit, (5.85) simplifies to

$$\tan \theta = \frac{2 \tan \beta}{(\gamma - 1) \tan^2 \beta + \gamma + 1}, \quad (5.87)$$

and it is now straightforward to obtain

$$\tan^2 \beta_c = \frac{\gamma + 1}{\gamma - 1} \quad (5.88)$$

and the critical wedge angle is therefore given by

$$\tan^2 \theta_c = \frac{1}{\gamma^2 - 1}. \quad (5.89)$$