

# An Introduction to Mathematical Physiology

S. J. Chapman, A. C. Fowler, R. Hinch and S. L. Waters

October 31, 2018

# Contents

Preface . . . . .	iv
<b>1 Enzyme kinetics</b>	<b>1</b>
1.1 Michaelis-Menten kinetics . . . . .	1
1.2 Inhibitors . . . . .	6
1.2.1 Competitive Inhibition . . . . .	6
1.2.2 Allosteric Inhibition . . . . .	7
1.3 Cooperative systems . . . . .	8
1.4 Glycolysis . . . . .	11
1.4.1 Glycolytic oscillations . . . . .	15
1.4.2 Limit cycles . . . . .	18
1.5 Notes and references . . . . .	21
1.5.1 Boom and bust dynamics . . . . .	22
Exercises . . . . .	22
<b>2 Trans-membrane ion transport</b>	<b>27</b>
2.1 Membrane transport . . . . .	27
2.1.1 Carrier mediated transport . . . . .	29
2.1.2 Active transport: the sodium-potassium pump . . . . .	31
2.1.3 The membrane potential . . . . .	32
2.1.4 Ionic currents . . . . .	34
2.1.5 Gating . . . . .	35
2.1.6 Multiple gates . . . . .	35
2.1.7 Non-identical gates . . . . .	37
2.2 Hodgkin-Huxley model . . . . .	37
2.3 FitzHugh-Nagumo equation . . . . .	40
2.4 Notes and references . . . . .	44
Exercises . . . . .	44
<b>3 Wave propagation in neurons</b>	<b>46</b>
3.1 Excitable media . . . . .	46
3.2 Wave propagation in the FitzHugh-Nagumo model . . . . .	47
3.3 Notes and references . . . . .	49
Exercises . . . . .	49

<b>4</b>	<b>Calcium dynamics</b>	<b>51</b>
4.1	Calcium-induced calcium release . . . . .	51
4.2	Intracellular oscillations . . . . .	53
4.3	Wave propagation . . . . .	62
4.4	Notes and references . . . . .	69
	Exercises . . . . .	69
<b>5</b>	<b>The electrochemical action of the heart</b>	<b>71</b>
5.1	Action potentials and the heart beat . . . . .	71
5.2	Cardiac cells . . . . .	73
	5.2.1 Sino-atrial node cells . . . . .	74
	5.2.2 Ventricular myocytes . . . . .	75
5.3	Cardiac tissue . . . . .	77
5.4	Wave propagation in two dimensions . . . . .	78
5.5	Target patterns . . . . .	80
5.6	Spiral waves . . . . .	82
5.7	Notes and references . . . . .	83
	Exercises . . . . .	83
<b>6</b>	<b>The heart as a pump</b>	<b>84</b>
6.1	The circulation . . . . .	84
6.2	A simple one-chamber compartment model . . . . .	88
	6.2.1 An approximate solution . . . . .	90
6.3	Nervous control of the heart . . . . .	97
6.4	Oscillatory patterns . . . . .	98
6.5	Mathematical models of the baroreflex . . . . .	99
	6.5.1 Ottesen model . . . . .	99
	6.5.2 De Boer model . . . . .	104
6.6	Notes and references . . . . .	106
	Exercises . . . . .	106
<b>7</b>	<b>Respiration</b>	<b>112</b>
7.1	The respiratory system . . . . .	112
	7.1.1 The mechanics of breathing . . . . .	114
7.2	Arterial chemoreceptors and blood gas control . . . . .	114
	7.2.1 Central chemoreceptors . . . . .	115
	7.2.2 Peripheral chemoreceptors . . . . .	115
7.3	Periodic breathing . . . . .	115
7.4	The Mackey-Glass model . . . . .	117
7.5	The Grodins model for $\text{CO}_2$ . . . . .	119
	7.5.1 Central and peripheral controllers . . . . .	125
7.6	Non-dimensionalisation . . . . .	126
	7.6.1 Dimensionless delays . . . . .	128
	7.6.2 Dimensionless controllers . . . . .	129

7.7	A simplified model . . . . .	129
7.7.1	Stability . . . . .	131
7.8	Notes and references . . . . .	133
	Exercises . . . . .	133
<b>8</b>	<b>Blood cell production</b>	<b>139</b>
8.1	Stem cells and their lineage . . . . .	140
8.2	Periodic haematopoietic diseases . . . . .	142
8.2.1	Cyclical neutropenia . . . . .	142
8.2.2	Chronic myelogenous leukaemia . . . . .	142
8.2.3	Polycythemia vera . . . . .	143
8.2.4	Aplastic anaemia . . . . .	144
8.2.5	Auto-immune haemolytic anaemia . . . . .	144
8.2.6	Cyclic thrombocytopenia . . . . .	144
8.3	Stem cell control models . . . . .	145
8.3.1	The $G_0$ model . . . . .	146
8.3.2	Relaxation oscillations . . . . .	149
8.4	Peripheral blood cell control models . . . . .	152
8.5	Maturation and delay . . . . .	154
8.5.1	Stem cell committal . . . . .	158
8.5.2	Non-dimensionalisation . . . . .	160
8.5.3	Steady state . . . . .	160
8.5.4	Wave propagation . . . . .	161
8.5.5	Spontaneous oscillations . . . . .	162
8.5.6	Peripherally controlled oscillations . . . . .	162
8.6	Notes and references . . . . .	165
8.6.1	Age and maturation . . . . .	165
	Exercises . . . . .	165
	<b>Glossary</b>	<b>175</b>
	<b>References</b>	<b>180</b>

# Preface

These notes accompany the course Mathematical Physiology. They are a development of an original draft dating from 2003, but which continue to be updated. The present version has been updated for the 2018 course.

We thank Michael Mackey, who helped develop the course on which these notes are based, during the tenure of a visiting Leverhulme Professorship at Oxford. We have received helpful advice from Mark McGuinness, Ivana Drobnjak and Christina Orphanidou.

Jon Chapman  
Andrew Fowler  
Rob Hinch  
Sarah Waters  
October 31, 2018

# Chapter 1

## Enzyme kinetics

Suppose that two chemicals, A and B say, react together on collision to produce the product C. The *law of mass action* states that the rate at which the reaction takes place is proportional to the number of sufficiently energetic collisions between the molecules A and B per unit time, which in turn is taken to be proportional to the concentrations of A and B. Thus we write



and, taking  $A$ ,  $B$ ,  $C$  to be the concentration of A, B and C respectively,

$$\frac{dC}{dt} = kAB. \quad (1.2)$$

The constant of proportionality  $k$  is known as the *rate constant* for the reaction, and depends on the geometrical shapes and sizes of the reactant molecules or ions, and on the temperature of the mixture.

While the law of mass action is extremely useful, there are many reactions to which it cannot be applied, usually because the reaction proceeds by a complex mechanism involving many elementary steps of the form (1.1). Often for biochemical reactions things are further complicated by the fact that many of the intermediate steps are unknown.

### 1.1 Michaelis-Menten kinetics

Many biochemical reactions are *catalysed* by *enzymes*. A catalyst is a molecule that helps to convert other molecules (called *substrates*) into products, but is not itself used up in the reaction. Enzymes are proteins which are extremely efficient catalysts, often giving increases in the rate of reaction by a factor of  $10^7$  or more. Just as importantly, they are highly specific, catalysing only one reaction of one specific substrate or family of substrates. Enzymes are also regulated, responding to a complicated network of positive and negative feedback mechanisms, thus allowing the rate of reaction to be precisely controlled.

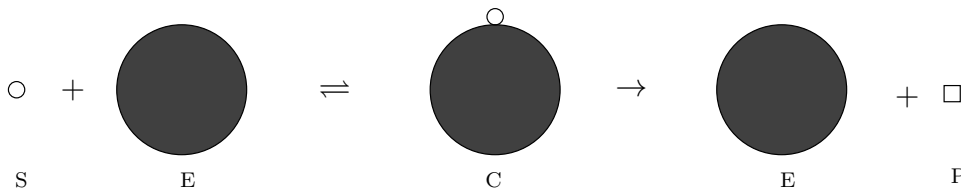

Figure 1.1: Schematic representation of the Michaelis-Menten reaction scheme

An enzyme works by lowering the activation energy of the reaction. This it may do by a number of different mechanisms. For example, it may aid in overcoming the electrostatic repulsion of like-charged molecules, or it may help in breaking existing bonds within the substrate.

A simple model for the action of an enzyme on a single substrate was formulated by Michaelis and Menten in 1913. They proposed that the reaction proceeds in two steps, as shown in figure 1.1. Firstly, the enzyme  $E$  may bind with the substrate  $S$  to form a complex  $C$ . Secondly, the complex  $C$  may break down into the product  $P$ , releasing the enzyme at the same time. The basic Michaelis-Menten reaction scheme is



Applying the law of mass action to each of the steps separately, with  $S$  = concentration of  $S$ , etc., gives

$$\begin{aligned} \frac{dS}{dt} &= k_{-1}C - k_1SE, \\ \frac{dE}{dt} &= (k_{-1} + k_2)C - k_1SE, \\ \frac{dC}{dt} &= k_1SE - (k_2 + k_{-1})C, \\ \frac{dP}{dt} &= k_2C. \end{aligned} \quad (1.4)$$

In writing down equations such as (1.4) (and indeed (1.2)) we are assuming that the medium in which the reaction is taking place is well-stirred, so that the concentrations of reactants are uniform in space. If this were not the case then we would need to allow the concentrations to be functions of position as well as time (so that we would have partial differential equations rather than ordinary differential equations) and we would need to take into account the diffusion and convection of reactants.

The overall reaction may be denoted as



where  $r$  denotes the overall reaction rate. Although (1.5) has the appearance of a first order reaction, the reaction rate  $r = k_2C$  is not constant (we shall see that it is

effectively a function of  $S$ ); this is a consequence of the fact that the overall reaction consists of a number of intermediate steps. Often biochemical reactions are modelled by the *Hill equation*

$$r = \frac{S^n}{K^n + S^n}, \quad (1.6)$$

an example being in the modelling of blood cell production in chapter 8. A particular example of this can be derived in models of enzyme kinetics, and in particular for those of cooperative enzymes, where the case  $n > 1$  may be derived.

The set of four equations in (1.4) is nonlinear and apparently intractable, but it may be simplified by noting firstly that the equation for  $P$  uncouples from the others, i. e., it can be found by direct integration once the other three equations for  $E$ ,  $C$  and  $S$  have been solved. Secondly, if we add equations (1.4)<sub>2</sub> and (1.4)<sub>3</sub>, then we see that

$$E + C = E_0 \quad (1.7)$$

is constant. This expresses the conservation of enzyme, and is a consequence of the observation that the enzyme is neither produced nor consumed, the total of bound and unbound enzyme being a constant quantity. This, together with the uncoupling of  $P$ , allows the system to be reduced to just two equations for  $C$  and  $S$ ;

$$\begin{aligned} \frac{dS}{dt} &= k_{-1}C - k_1S(E_0 - C), \\ \frac{dC}{dt} &= k_1S(E_0 - C) - (k_2 + k_{-1})C. \end{aligned} \quad (1.8)$$

Typical initial conditions for the system (1.4) would consist of given concentrations of substrate and enzyme, and no product or complex, that is,  $P = C = 0$ ,  $S = S_0$ ,  $E = E_0$ . For (1.8), we therefore have

$$S = S_0, \quad C = 0 \quad \text{at} \quad t = 0. \quad (1.9)$$

The first step in a systematic mathematical analysis is to nondimensionalise the system. We set

$$S = S_0s, \quad C = E_0c, \quad t = \frac{t'}{k_1E_0}, \quad (1.10)$$

to give

$$\frac{ds}{dt'} = -s + c(s + K' - \lambda), \quad (1.11)$$

$$\varepsilon \frac{dc}{dt'} = s - (s + K')c, \quad (1.12)$$

with initial conditions

$$s(0) = 1, \quad c(0) = 0, \quad (1.13)$$

where

$$K' = \frac{k_{-1} + k_2}{k_1S_0}, \quad \lambda = \frac{k_2}{k_1S_0}, \quad \varepsilon = \frac{E_0}{S_0}.$$



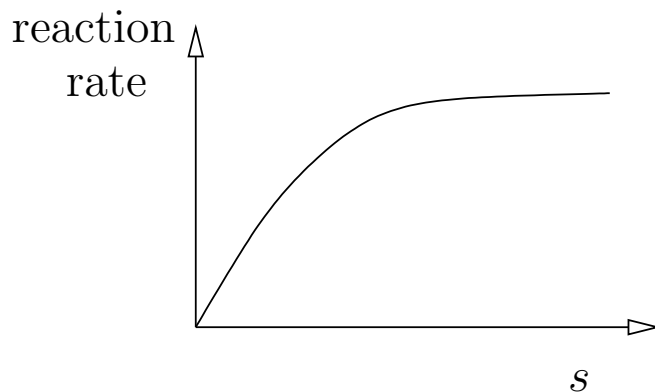

Figure 1.2: A typical Michaelis-Menten reaction rate

The remarkable effectiveness of enzymes as catalysts is reflected in the extremely small concentrations needed in comparison to the substrate. Thus the parameter  $\varepsilon$  is small, typically in the range  $10^{-2}$  to  $10^{-7}$ . This means that the reaction (1.12) equilibrates very rapidly by comparison with (1.11), and remains near equilibrium even as  $s$  changes. Thus, to a first approximation we may take  $\varepsilon \frac{dc}{dt'} = 0$ , so that

$$c = \frac{s}{s + K'}, \quad (1.14)$$

$$\frac{ds}{dt'} = -\lambda c = -\frac{\lambda s}{s + K'}. \quad (1.15)$$

The approximation above is known as the *quasi-steady state* approximation. Note that we are not claiming that  $dc/dt' = 0$ ;  $c$  will vary through equation (1.14) as  $s$  varies.

The quasi-steady state approximation was first used by Briggs and Haldane in 1925, and is the basis for most present-day descriptions of enzyme reactions<sup>1</sup>. Equation (1.15) describes the rate of transformation of the substrate, and is known as a *Michaelis-Menten law*. It has the general property of enzyme-catalysed reactions that for small concentrations of substrates the reaction rate is linear in the substrate concentration, as in the law of mass action, but for large substrate concentrations the reaction rate approaches a constant value (as the enzyme is working at full capacity). Dimensionally, under the quasi-steady state approximation, the rate of reaction  $r = \frac{dP}{dt} = -\frac{dS}{dt} = -S_0 E_0 k_1 \frac{ds}{dt'}$ , and thus

$$r = \frac{k_2 E_0 S}{K + S}, \quad (1.16)$$

---

<sup>1</sup>In fact Briggs and Haldane arrived at the approximation by the erroneous argument that the rates of formation and breakdown of complex were essentially equal at all times, so that  $dC/dt$  should be zero.

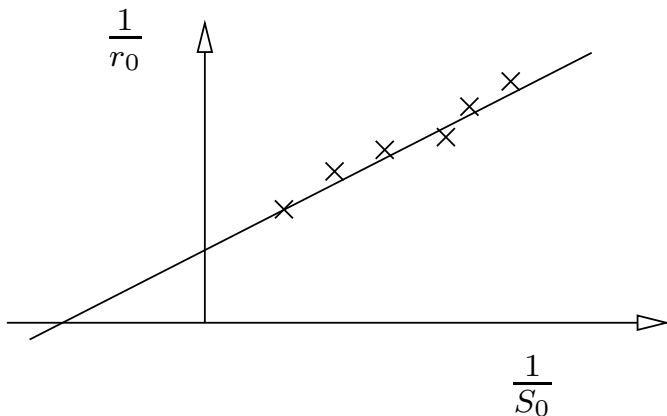

Figure 1.3: A Lineweaver-Burk plot

where the Michaelis constant is

$$K = \frac{k_{-1} + k_2}{k_1}. \quad (1.17)$$

Although the individual reaction rate constants are difficult to measure, the ratio  $K$  can be measured relatively easily due to the observation that the initial reaction rate  $r_0$  at  $t = 0$  is given by

$$\frac{1}{r_0} = \frac{1}{k_2 E_0} + \frac{K}{k_2 E_0} \frac{1}{S_0},$$

so that  $1/r_0$  is a linear function of  $1/S_0$ . Plots of  $1/r_0$  against  $1/S_0$  are known as *Lineweaver-Burk* plots; from them  $K$  and  $k_2 E_0$  can be found. Data such as that indicated in figure 1.3 is obtained by repeating the experiment for a number of different initial substrate concentrations, and then plotting the initial (apparent) reaction rate as a function of initial substrate concentration.

Note that with  $c$  given by (1.14),

$$c(0) = \frac{s(0)}{s(0) + K'} = \frac{1}{1 + K'} \neq 0, \quad (1.18)$$

so that the initial condition is not satisfied. There is an initial rapid transient (a boundary layer in time) when  $t' = O(\varepsilon)$ , during which the quasi-steady state approximation does not hold. To examine this transient we rescale the time variable by writing  $t' = \varepsilon \tau$  to give

$$\frac{ds}{d\tau} = \varepsilon (-s + c(s + K' - \lambda)), \quad (1.19)$$

$$\frac{dc}{d\tau} = s - (s + K')c. \quad (1.20)$$

Thus to leading order  $ds/d\tau = 0$ , so that  $s$  is constant. Since  $s(0) = 1$  we therefore have  $s \equiv 1$ , giving

$$\frac{dc}{d\tau} = 1 - (1 + K')c, \quad (1.21)$$

so that

$$c = \frac{1}{1 + K'} \left( 1 - e^{-(1+K')\tau} \right). \quad (1.22)$$

This short-time behaviour satisfies the initial condition  $c(0) = 0$ , and gives  $c \sim 1/(1 + K')$  as we move out of the boundary layer (as  $\tau \sim \infty$ ) in agreement with (1.18).

## 1.2 Inhibitors

An enzyme *inhibitor* is a substance which inhibits the catalytic action of the enzyme. Inhibition is a common feature of enzyme catalysed reactions, and is a means by which the activity of enzymes may be controlled.

There are many different types of enzyme inhibitors. Two common types of enzyme inhibitor which may be easily modelled are *competitive* inhibitors and *allosteric* inhibitors. To understand the way that an inhibitor works, and the distinction between competitive and allosteric inhibition, it is useful to recall that enzymes are usually large proteins (usually much larger than the substrate molecule), and that their catalytic properties are believed to arise from *active sites* embedded in the enzyme to which the substrate can bind. The active sites arise as a result of the three-dimensional structure of the enzyme molecule, and are highly specific, with the substrate matching the site in a “lock-and-key” fashion. However, if another molecule has a similar structure to the substrate molecule, it may also bind to the active site, preventing the binding of the substrate, and decreasing the effectivity of the enzyme. Because the inhibitor molecule binds to the active site in competition with the substrate, such inhibition is called competitive inhibition.

However, enzymes usually have many other binding sites, distinct from the active site. These other binding sites are known as *allosteric* or *regulatory* binding sites. When a molecule binds to one of these other sites it may alter the three-dimensional shape of the enzyme, thus affecting the binding of the substrate at the active site. The molecules that bind at the allosteric sites are called *effectors* or *modifiers*. They may increase the effectiveness of the active site, in which case they are called allosteric activators, or they may decrease the effectiveness, in which case they are called allosteric inhibitors.

### 1.2.1 Competitive Inhibition

The simplest model example of a competitive inhibitor is one in which the substrate cannot bind when the inhibitor is bound to the enzyme, so that the reaction stops. Labelling the inhibitor as I, and denoting the enzyme complex with the substrate  $C_S$  and the enzyme complex with the inhibitor  $C_I$ , the reaction scheme is

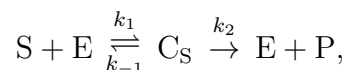



Using the law of mass action gives

$$\begin{aligned} \frac{dS}{dt} &= k_{-1}C_S - k_1SE, \\ \frac{dI}{dt} &= k_{-3}C_I - k_3IE, \\ \frac{dE}{dt} &= (k_{-1} + k_2)C_S - k_1SE + k_{-3}C_I - k_3IE, \\ \frac{dC_S}{dt} &= k_1SE - (k_2 + k_{-1})C_S, \\ \frac{dC_I}{dt} &= k_3IE - k_{-3}C_I, \\ \frac{dP}{dt} &= k_2C_S. \end{aligned} \quad (1.24)$$

As before the equation for  $P$  decouples and  $\frac{d(E + C_S + C_I)}{dt} = 0$ , so that enzyme is conserved and

$$E + C_S + C_I = E_0. \quad (1.25)$$

Under the quasi-steady state approximation

$$\begin{aligned} C_S &= \frac{K_i E_0 S}{K_m I + K_i S + K_m K_i}, \\ C_I &= \frac{K_m E_0 I}{K_m I + K_i S + K_m K_i}, \end{aligned} \quad (1.26)$$

where

$$K_m = \frac{k_2 + k_{-1}}{k_1}, \quad K_i = \frac{k_{-3}}{k_3}, \quad (1.27)$$

and the rate of reaction is

$$r = \frac{k_2 E_0 S K_i}{K_m I + K_i S + K_m K_i} \quad (1.28)$$

(see also question 1.3). The effect of the inhibitor is to increase the effective equilibrium constant of the enzyme by a factor of  $1 + I/K_i$  from  $K_m$  to  $K_m(1 + I/K_i)$ .

## 1.2.2 Allosteric Inhibition

If the inhibitor binds at a different site from the active site (i. e., at an allosteric site), then it is possible for the enzyme to be bound to both the inhibitor and the substrate at the same time, and there are four possible states for the enzyme, which we denote

by E (unbound),  $C_S$  (bound to the substrate only),  $C_I$  (bound to the inhibitor only) and  $C_{IS}$  (bound to the substrate and the inhibitor). The reaction scheme is then

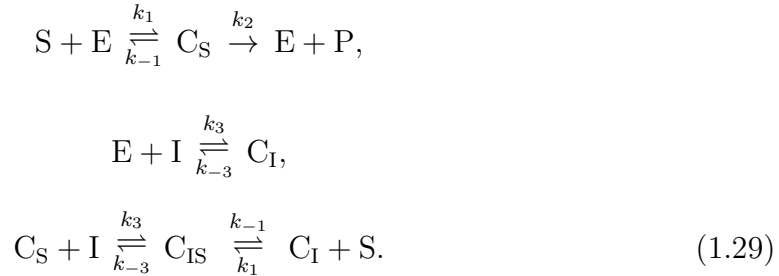

The possible states of the enzyme and the rates of transition between these states are

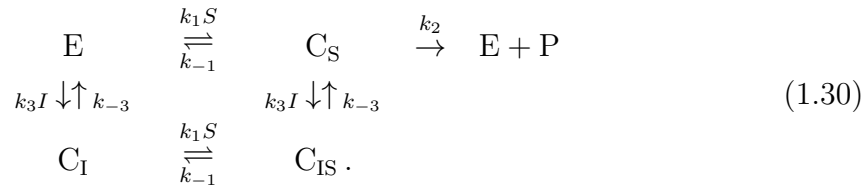

The analysis of the model now proceeds in much the same way as before. Under the quasi-steady state approximation the rate of reaction is

$$r = \left( \frac{r_{\max} K_3}{I + K_3} \right) \left( \frac{S(k_{-1} + k_3 I + k_1 S + k_{-3})}{k_1(S + K_1)^2 + (S + K_1)(k_3 I + k_{-3} + k_2) + k_2 k_{-3}/k_1} \right), \tag{1.31}$$

where  $K_3 = k_{-3}/k_3$  and  $K_1 = k_{-1}/k_1$ .

### 1.3 Cooperative systems

Often the reaction rates of enzyme-catalysed reactions are more sigmoidal in nature than is predicted by the simple Michaelis-Menten law. This can result from cooperative effects.

Many enzymes have more than one active site, so that many substrate molecules can bind to the enzyme at the same time. Moreover, if a substrate molecule is bound at one active site, this can affect the binding of substrate molecules at other active sites (as in allosteric activation/inhibition).

Consider the simplest cooperative system of an enzyme with two active sites, as shown in figure 1.4. Assuming the two active sites to be identical, and denoting the enzyme complex with one substrate molecule (at either site) by  $C_1$  and with two substrate molecules by  $C_2$ , the reaction scheme is

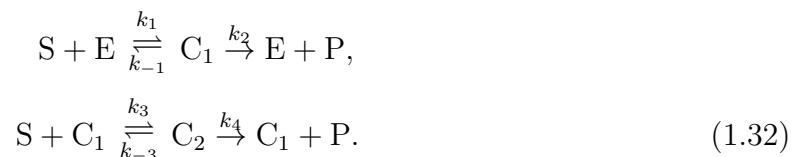

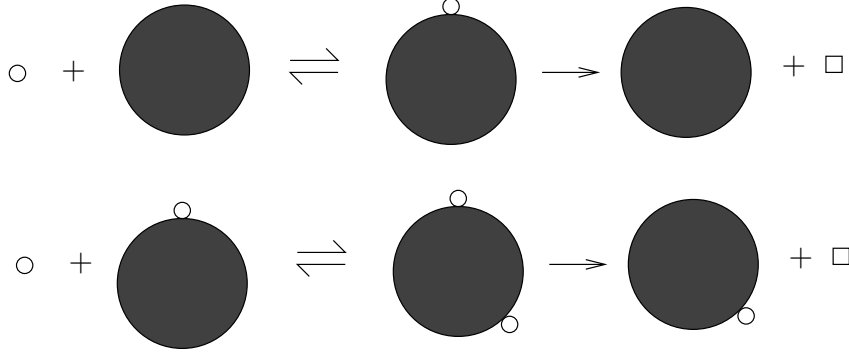

Figure 1.4: Schematic representation of an enzyme with two active sites

As usual  $P$  will uncouple and enzyme will be conserved, so that  $E + C_1 + C_2 = E_0$ . Thus we only need to write down the remaining equations for  $S$ ,  $C_1$  and  $C_2$ . These are

$$\begin{aligned}
 \frac{dS}{dt} &= k_{-1}C_1 - k_1SE + k_{-3}C_2 - k_3SC_1, \\
 \frac{dC_1}{dt} &= k_1SE - (k_2 + k_{-1})C_1 - k_3SC_1 + (k_4 + k_{-3})C_2, \\
 \frac{dC_2}{dt} &= k_3SC_1 - (k_4 + k_{-3})C_2.
 \end{aligned} \tag{1.33}$$

Nondimensionalising by setting

$$S = sS_0, \quad C_1 = c_1E_0, \quad C_2 = c_2E_0, \quad t = t'/k_1E_0, \tag{1.34}$$

gives

$$\begin{aligned}
 \frac{ds}{dt'} &= \frac{k_{-1}}{k_1S_0}c_1 - s(1 - c_1 - c_2) + \frac{k_{-3}}{k_1S_0}c_2 - \frac{k_3}{k_1}sc_1, \\
 \varepsilon \frac{dc_1}{dt'} &= s(1 - c_1 - c_2) - \frac{k_2 + k_{-1}}{k_1S_0}c_1 - \frac{k_3}{k_1}sc_1 + \frac{k_4 + k_{-3}}{k_1S_0}c_2, \\
 \varepsilon \frac{dc_2}{dt'} &= \frac{k_3}{k_1}sc_1 - \frac{k_4 + k_{-3}}{k_1S_0}c_2.
 \end{aligned} \tag{1.35}$$

As before, we suppose  $\varepsilon \ll 1$ , whence we deduce the quasi-steady state approximation

$$\begin{aligned}
 0 &\approx s(1 - c_1 - c_2) - \frac{k_2 + k_{-1}}{k_1S_0}c_1 - \frac{k_3}{k_1}sc_1 + \frac{k_4 + k_{-3}}{k_1S_0}c_2, \\
 0 &\approx \frac{k_3}{k_1}sc_1 - \frac{k_4 + k_{-3}}{k_1S_0}c_2,
 \end{aligned} \tag{1.36}$$

i. e.,

$$\begin{aligned}
 c_1 &= \frac{K'_2s}{s^2 + K'_2s + K'_1K'_2}, \\
 c_2 &= \frac{s^2}{s^2 + K'_2s + K'_1K'_2},
 \end{aligned} \tag{1.37}$$

where

$$K'_1 = \frac{k_{-1} + k_2}{k_1 S_0}, \quad K'_2 = \frac{k_4 + k_{-3}}{k_3 S_0}. \quad (1.38)$$

Dimensionally, under the quasi-steady state assumption, the rate of reaction is found after some algebra to be

$$r = \frac{(k_2 K_2 + k_4 S) E_0 S}{K_1 K_2 + K_2 S + S^2}, \quad (1.39)$$

where

$$K_1 = \frac{k_{-1} + k_2}{k_1}, \quad K_2 = \frac{k_4 + k_{-3}}{k_3}. \quad (1.40)$$

If the rates of binding (and reaction) at each site are identical and independent then

$$k_1 = 2k_3, \quad k_{-3} = 2k_{-1}, \quad k_4 = 2k_2. \quad (1.41)$$

The reaction rate is then given by

$$r = \frac{2k_2 E_0 S}{K + S}, \quad (1.42)$$

where

$$K = \frac{2(k_{-1} + k_2)}{k_1}. \quad (1.43)$$

Thus, as expected, the reaction rate is exactly twice that for an enzyme with a single active site.

If cooperativity is large then the rate of binding of the first substrate molecule is small, but the rate of binding of the second once the first is attached is large. This corresponds to the limit  $k_1 \sim 0$ ,  $k_3 \sim \infty$ , with  $k_1 k_3$  finite, so that  $K_1 \sim \infty$ ,  $K_2 \sim 0$ , with  $K_1 K_2$  finite. In this limit the reaction rate

$$r \approx \frac{k_4 E_0 S^2}{K_1 K_2 + S^2}, \quad (1.44)$$

which is a Hill equation with exponent 2.

If the enzyme has binding sites for  $n$  substrate molecules, then in the same limit of large cooperativity  $k_i \sim 0$  for  $i < n$ ,  $k_n \sim \infty$ , with  $\prod_{i=1}^n k_i$  finite (so that  $K_i \sim \infty$  for  $i < n$ ,  $K_n \sim 0$  with  $\prod_{i=1}^n K_i$  finite) the reaction rate is approximately

$$r = \frac{r_{\max} S^n}{\prod_{i=1}^n K_i + S^n}, \quad (1.45)$$

which is a Hill equation with exponent  $n$  (see also exercise 1.2). Such a Hill equation is often used to model the reaction rate when details of the intermediate steps are not known, but where cooperative behaviour is suspected, with the parameters  $r_{\max}$  and  $n$  fitted from experiment.

While the model (1.33) can predict the overall reaction rate given the individual rate constants, it gives no explanation of why cooperative behaviour should occur,

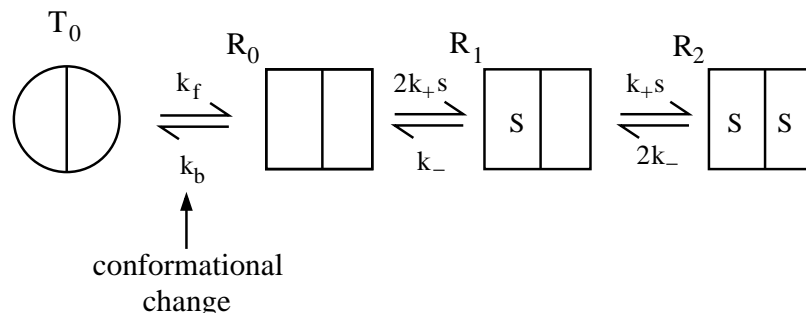

Figure 1.5: A schematic diagram of the reaction scheme for a simple Monod-Wyman-Changeux model.

i. e., why the rate constant  $k_3$  should be larger than  $\frac{1}{2}k_1$ . One of the first models that was proposed to explain cooperativity was the allosteric theory of Monod-Wyman-Changeux, which is illustrated in figure 1.5. It assumes that the protein has two conformational states (denoted in the figure by a circle and a square), and that these two states differ in their ability to bind to the substrate molecules. In the simplest model (shown in the diagram), only when the protein is in one of the conformational states (the square) can the substrate bind to the active sites. However, the protein can only switch between conformations when no substrate molecules are bound, so that once one substrate molecule is bound the protein is “locked” in that confirmation until the substrate molecule unbinds.

It is straightforward to write down rate equations for the reaction scheme illustrated in figure 1.5. The rate of reaction is again a sigmoidal function of substrate concentration  $S$ . This is illustrated in detail in section 1.4 below.

## 1.4 Glycolysis

We have seen that the Michaelis-Menten law for the rate of enzyme-catalysed reactions differs from the simple law of mass action, and that cooperative and inhibitory effects may lead to even more complicated reaction rates as functions of substrate concentration. However, with some reactions things may be more complicated still, with positive feedback loops leading to oscillations in the concentrations.

An example of a biochemical pathway in which oscillations can occur is glycolysis. This is part of the sequence of reactions converting foodstuffs to energy – e. g., the oxidation of glucose:

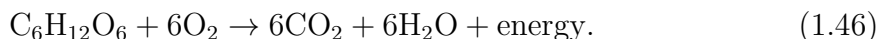

In some circumstances, oscillations can occur in the concentrations. One part of the pathway consists of the transformation of the substrate ATP (adenosine triphosphate) to ADP (adenosine diphosphate) via the action of the allosteric enzyme PFK (phos-



phofructokinase). The rate of this reaction is, however, modified by the ADP itself in an autocatalytic fashion.

We initially consider as an example the precise situation shown in figure 1.5, in which we suppose that the allosteric enzyme PFK is a *dimer* consisting of two subunits (*protomers*) which can exist (together) in either of two conformations, T and R. We suppose that ATP can only bind to PFK in the R form, and that each protomer of R can bind one molecule of ATP. We denote the concentration of ATP by  $s$  and that of ADP by  $p$ , and initially ignore binding of ADP to PFK. There are four states of the enzyme, which we denote as  $T_0$ ,  $R_0$ ,  $R_1$  and  $R_2$ , with the subscript denoting the number of molecules of ATP bound to the enzyme. The reaction scheme between these different states is thus

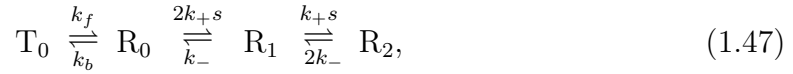

where the factors of two arise through the number of bound or unbound sites available.

It is straightforward to write down the rate equations for these variables, and these are

$$\begin{aligned} \dot{T}_0 &= -k_f T_0 + k_b R_0, \\ \dot{R}_0 &= k_f T_0 - k_b R_0 - 2k_+ s R_0 + k_- R_1, \\ \dot{R}_1 &= 2k_+ s R_0 - k_- R_1 - k_+ s R_1 + 2k_- R_2, \\ \dot{R}_2 &= k_+ s R_1 - 2k_- R_2, \\ \dot{s} &= -2k_+ s R_0 + k_- R_1 - k_+ s R_1 + 2k_- R_2. \end{aligned} \quad (1.48)$$

In keeping with the quasi-steady state assumption, we assume the first four of these equations are in equilibrium, and then after some algebra, we find that

$$T_0 = \frac{LK^2 R_2}{s^2}, \quad R_0 = \frac{K^2 R_2}{s^2}, \quad R_1 = \frac{2K R_2}{s}, \quad (1.49)$$

where

$$L = \frac{k_b}{k_f}, \quad K = \frac{k_-}{k_+}. \quad (1.50)$$

The fraction of bound sites on all forms of the enzyme is  $Y = \frac{R_1 + 2R_2}{2(T_0 + R_0 + R_1 + R_2)}$ , and using (1.49) we find that this is

$$Y = \frac{S(1+S)}{L + (1+S)^2}, \quad (1.51)$$

where

$$S = \frac{s}{K}. \quad (1.52)$$

Now suppose that the product ADP (denoted P) with concentration  $p$  is produced at a rate  $k$  per bound site. Then we have the additional reactions



and these modify the model in (1.48) simply by replacing  $k_-$  by  $k + k_-$ . Thus in this case the fraction of bound sites is still given by (1.51), but where now

$$S = \frac{s}{K_m}, \tag{1.54}$$

and

$$K_m = \frac{k_- + k}{k_+}. \tag{1.55}$$

The rate of reaction  $r$  in the overall reaction  $S \rightarrow P$  is

$$r = kR_1 + 2kR_2 = 2kR_2 \left(1 + \frac{1}{S}\right). \tag{1.56}$$

We can relate this to  $Y$  by noting that the enzyme is conserved;  $T_0 + R_0 + R_1 + R_2 = e_0$  is constant, so that, using (1.49), we find

$$r = 2ke_0Y. \tag{1.57}$$

Because  $Y$  is a sigmoidal function of  $S$ , so also is  $r$ , as we mentioned earlier.

Now let us add in the effect of feedback, that is we allow the product P to bind as a second substrate to the enzyme, and specifically we will suppose that binding of S prevents further binding of P. No production of P is yet invoked. The reaction scheme is shown in figure 1.6, and it is a simple if tedious matter to write down the corresponding rate equations. This is deferred to question 1.4. Assuming the corresponding ten enzyme equations are in equilibrium, we find, after some algebra<sup>2</sup>, that the fraction of bound sites is now given by

$$Y = \frac{S(1+S)(1+P)^2}{L + (1+S)^2(1+P)^2}, \tag{1.58}$$

where

$$S = \frac{s}{K_s}, \quad P = \frac{p}{K_p}, \tag{1.59}$$

and in terms of the reaction rates indicated in figure 1.6,

$$L = \frac{k_b}{k_f}, \quad K_p = \frac{k_-^*}{k_+^*}, \quad K_s = \frac{k_-}{k_+}. \tag{1.60}$$

---

<sup>2</sup>It is simplest to first write the nine overall reaction rates  $r_{00} = k_f T - k_b R_{00}$ , etc., and then the rate equations are  $\dot{T} = -r_{00}$ , etc.; equilibrium shows that all  $r_{ij} = 0$ , which yields a sequence of expressions for  $R_{ij} \propto R_{00}$ . Conservation of enzyme yields  $R_{00}$ , and the number of S-bound sites follows easily.

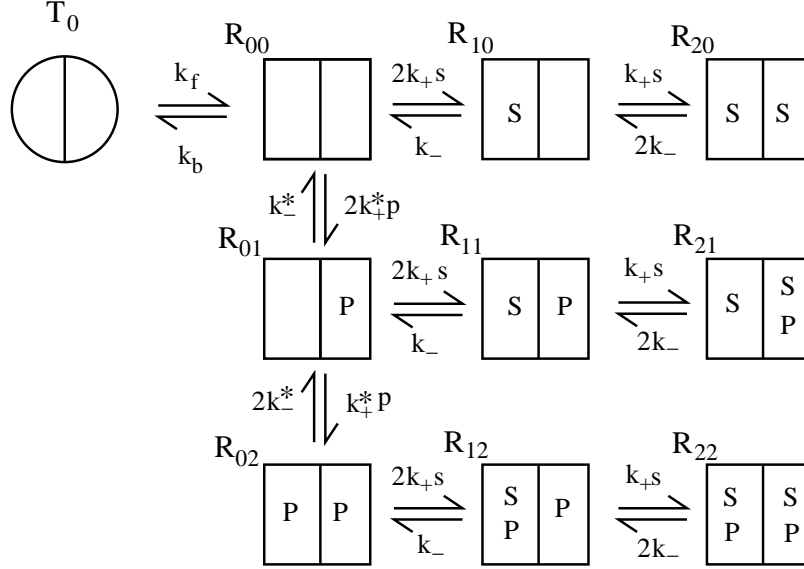
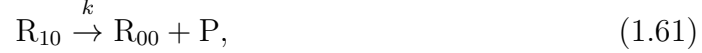

Figure 1.6: Reaction scheme for the Monod-Wyman-Changeux dimer with product feedback. Binding of  $S$  (ATP) is assumed to inhibit further binding of  $P$  (ADP).

If we now add production of  $P$  to the scheme via reactions involving enzymes with bound  $S$  such as



this adds terms to the equations of the form

$$\dot{p} = kR_{10} + \dots, \quad \dot{R}_{10} = -kR_{10} + \dots, \quad \dot{R}_{00} = kR_{10} + \dots \quad (1.62)$$

These latter terms combine with the dissociation reactions such as



and it is clear that the effect of production of  $p$  is simply to change  $k_-$  to  $k_- + k$  in the enzyme model of figure 1.6. Hence the overall reaction rate in the reaction  $S \xrightarrow{r} P$  is just

$$r = 2ke_0Y \quad (1.64)$$

as before, the bound site fraction is still given by (1.58), but  $S$  is now defined by

$$S = \frac{s}{K_m}, \quad (1.65)$$

where

$$K_m = \frac{k_- + k}{k_+}. \quad (1.66)$$

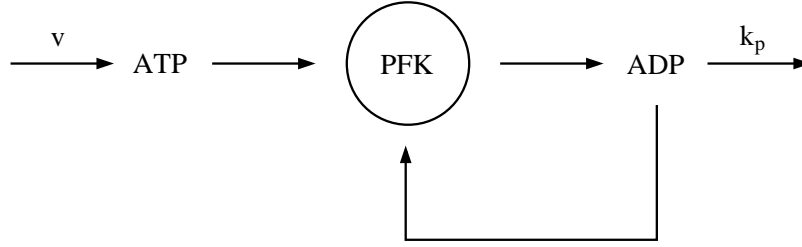

Figure 1.7: A part of the glycolytic path of reactions involving glucose. ATP is converted to ADP; however, this can bind to the allosteric enzyme PFK, which can then affect the rate of reaction.

We can now write a model for the ATP–ADP reaction scheme indicated in figure 1.7. If, as indicated,  $S$  is produced at a rate  $v$ , while  $P$  is removed by first order decay with rate coefficient  $k_p$ , then a suitable model is

$$\begin{aligned}\dot{s} &= v - r, \\ \dot{p} &= -k_p p + r,\end{aligned}\tag{1.67}$$

where  $r$  is the reaction rate in (1.64). It is convenient to write these equations in dimensionless form by scaling

$$s \sim K_m, \quad p \sim K_p, \quad t \sim \frac{1}{k_p}.\tag{1.68}$$

From this we derive the dimensionless model

$$\begin{aligned}\dot{S} &= \mu - \phi(S, P), \\ \dot{P} &= -P + K\phi(S, P),\end{aligned}\tag{1.69}$$

where

$$\phi = \frac{\beta S(1+S)(1+P)^2}{L + (1+S)^2(1+P)^2}, \quad \beta = \frac{2ke_0}{k_p K_m}, \quad \mu = \frac{v}{k_p K_m}, \quad K = \frac{K_m}{K_p}, \quad L = \frac{k_b}{k_f}.\tag{1.70}$$

As we shall see, this model supports self-sustained oscillatory solutions.

### 1.4.1 Glycolytic oscillations

It is straightforward in principle to analyse the solution in the  $(S, P)$  phase plane, but this is complicated by the complexity of the rate function  $\phi$ ; and this function is even more complicated for more complex models of the enzyme. Simplification ensues by using realistic values for the dimensionless parameters  $\mu$ ,  $L$ ,  $\beta$  and  $K$ . Typical values of these (for example, for ATP–ADP conversion in yeast) satisfy  $L \gg \beta \gg 1$ , with  $\mu \sim K \sim 1$ , and we shall assume these orders of magnitude. Typical quoted values are in the range  $L \sim 10^6$ ,  $\beta \sim 10^3$ , for example.

It is simple to see from (1.69) that  $S$  and  $P$  remain positive since  $\dot{S} > 0$  on  $S = 0$  and  $\dot{P} > 0$  on  $P = 0$ ,  $S > 0$ . Further, there is a unique fixed point in the positive quadrant, since we must have  $P = K\mu$ , and  $\phi$  is certainly an increasing function of  $S$  if  $L \gg \beta$ . Next, we study the shape of the nullclines (where the derivatives of  $S$  and  $P$  are zero), assuming  $L \gg \beta \gg 1$  and  $K \sim \mu \sim O(1)$ . The  $S$  nullcline is given by

$$\frac{\beta S(1+S)(1+P)^2}{L + (1+S)^2(1+P)^2} = \mu. \quad (1.71)$$

Suppose that  $S, P \gg 1$ . Then this is approximated by

$$\frac{\beta S^2 P^2}{L + S^2 P^2} = \mu, \quad (1.72)$$

i. e., the  $S$  nullcline at large  $P$  is given by the hyperbola

$$SP \approx \left[ \frac{\mu L}{\beta - \mu} \right]^{1/2}. \quad (1.73)$$

Note that this is consistent with the assumption that  $S, P \gg 1$ , since the right hand side is of  $O(L/\beta)^{1/2} \gg 1$ . The approximations break down, but not dramatically, if  $S \rightarrow 0$  or  $P \rightarrow 0$ . As  $P \rightarrow 0$ , the asymptote at  $P = 0$  is in fact at  $P = -1$ , and as  $P \rightarrow 0$ ,  $S$  cuts the  $S$  axis at  $S \approx \left( \frac{\mu L}{\beta - \mu} \right)^{1/2} \gg 1$ . As  $S$  becomes small at large  $P$  ( $\gg L^{1/2}$ ), we see that  $S \rightarrow \mu/\beta \ll 1$ . Thus the  $S$  nullcline is monotonically decreasing as  $P$  increases, and reasonably approximated everywhere by (1.73).

The  $P$  nullcline where  $\dot{P} = 0$  is given by

$$P = \frac{\beta K S(1+S)(1+P)^2}{L + (1+S)^2(1+P)^2}. \quad (1.74)$$

Now we see in the  $S$  nullcline from (1.73) that  $SP \ll \sqrt{L}$ , and with this assumption, the  $P$  nullcline takes the approximate form

$$S + S^2 \approx \frac{L}{\beta K} \frac{P}{(1+P)^2}. \quad (1.75)$$

Since the left hand side is an increasing function of  $S$ , this gives  $S$  as a unimodal (one-humped) function of  $P$ , increasing from zero at  $P = 0$  to a maximum, and then decreasing towards zero as  $P \rightarrow \infty$ . While  $P \sim O(1)$ ,  $S$  is large, thus

$$S \approx \left[ \frac{L}{\beta K} \frac{P}{(1+P)^2} \right]^{1/2}, \quad (1.76)$$

and  $SP \ll \sqrt{L}$  as assumed. As  $P$  becomes large, the approximation becomes

$$S \approx \left[ \frac{L}{\beta K P} \right]^{1/2}, \quad (1.77)$$

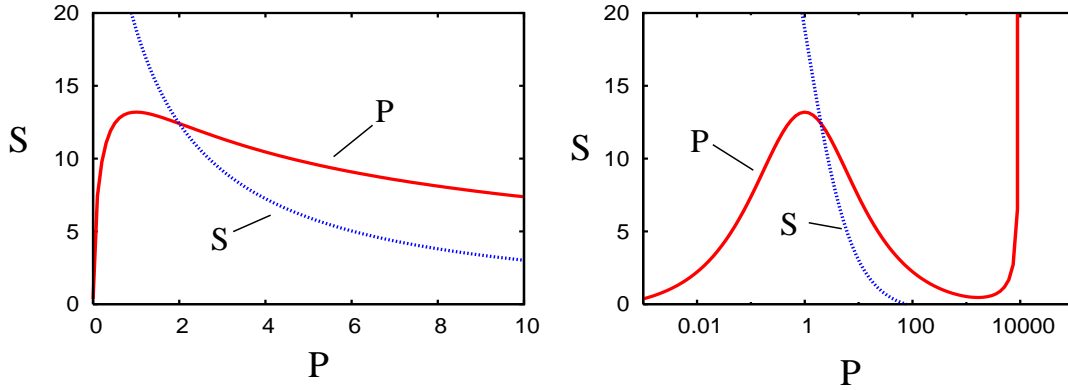

Figure 1.8:  $S$  and  $P$  nullclines (linear and log plots) when  $\mu = 2$ ,  $K = 1$ ,  $\beta = 10^4$  and  $L = 0.75 \times 10^7$ .

and the assumption that  $SP \ll \sqrt{L}$  remains valid until  $P \gtrsim \beta$ .

For  $P \gtrsim \beta \gg 1$  and while  $S$  is still large, we anticipate that then  $SP \gtrsim \sqrt{L}$ , and the nullcline is approximated by  $P \approx \frac{\beta K S^2 P^2}{L + S^2 P^2}$ , i. e.,

$$\frac{1}{\beta K S} = \frac{SP}{L + S^2 P^2}. \quad (1.78)$$

The right hand side is a unimodal function of  $SP$ , so that  $S$  decreases from  $\infty$  to a minimum and then increases again as  $SP$  increases. This then implies the same behaviour for  $S$  as  $P$  increases (think graphically!). Further, as  $P \rightarrow 0$ , then  $S \rightarrow \infty$  and  $SP \rightarrow 0$  in this approximation, so that  $\frac{1}{\beta K S} \approx \frac{SP}{L}$  which is identical to (1.75), which is itself the large  $P$  limit of the unimodal approximation when  $P \ll O(\beta)$ . Thus these two approximations match to each other and provide a uniform approximation for the  $P$  nullcline, which has a pseudo-cubic shape as shown in figure 1.8. A uniform approximation which is also approximated by both (1.76) and (1.78) is

$$S \approx \left[ \frac{LP}{\beta K(1+P)^2 - P^3} \right]^{1/2}. \quad (1.79)$$

Note from (1.79) that  $S \rightarrow \infty$  as  $P \rightarrow \beta K$ , approximately. In fact this can be seen from (1.74) since the maximum of the right hand side is  $\beta K$  when  $S \rightarrow \infty$ .

We denote the local maximum of the  $P$  nullcline as  $U$  and the local minimum as  $V$  (see figure 1.8). The stability of the fixed point then depends on whether the fixed point of the system lies to the left of  $U$ , to the right of  $V$ , or between  $U$  and  $V$ . It is easy to use the approximations described above to estimate the locations of these points. This is deferred to question 1.6; the results are that  $U$  is approximately at  $P = 1$ ,  $S = \left( \frac{L}{4\beta K} \right)^{1/2}$ , while  $V$  is approximately at  $S = \frac{2L^{1/2}}{\beta K}$ ,  $P = \frac{\beta K}{2}$ .

If we linearise the equations (1.69) about the fixed point  $(S_0, P_0)$  by writing  $S = S_0 + \sigma$ ,  $P = P_0 + \pi$ , then we find

$$\begin{pmatrix} \dot{\sigma} \\ \dot{\pi} \end{pmatrix} = \begin{pmatrix} -\phi_S & -\phi_P \\ K\phi_S & K\phi_P - 1 \end{pmatrix} \begin{pmatrix} \sigma \\ \pi \end{pmatrix}. \quad (1.80)$$

The determinant of the matrix in this equation is  $\phi_S$  which is positive, and therefore instability occurs (as a Hopf bifurcation) if and only if the trace of the matrix is positive, i. e.,  $K\phi_P > \phi_S + 1$ . Since the slope of the  $P$  nullcline  $S'_P$  is easily computed to be

$$S'_P = \frac{1 - K\phi_P}{K\phi_S}, \quad (1.81)$$

we can deduce that instability occurs if and only if  $-S'_P > \frac{1}{K}$ . In particular the  $P$  nullcline must have negative slope for instability, i. e., the fixed point must lie between  $U$  and  $V$ .

We use (1.73) and (1.76) to calculate the values of  $S$ ,  $P$  and  $S'_P$  at the fixed point.  $P$  is given implicitly by

$$\frac{P^3}{(1+P)^2} = \mu K, \quad (1.82)$$

and

$$S \approx \left(\frac{\mu L}{\beta}\right)^{1/2} \frac{1}{P}, \quad (1.83)$$

whence

$$-2SS'_P = \frac{L}{\beta K} \left[ \frac{P-1}{(1+P)^3} \right]. \quad (1.84)$$

Instability thus occurs if

$$\frac{P(P-1)}{(1+P)^3} > 2\sqrt{\frac{\mu\beta}{L}}, \quad (1.85)$$

and thus approximately if  $P \gtrsim 1$ . Bearing in mind (1.82), this implies that instability occurs for

$$\mu K \gtrsim \frac{1}{4}. \quad (1.86)$$

## 1.4.2 Limit cycles

Figure 1.9 shows the limit cycle oscillation which ensues when we use the values  $\mu = 2$ ,  $K = 1$ ,  $L = 0.75 \times 10^7$ , and  $\beta = 10^4$ . The presence of the large parameters  $L$  and  $\beta$  suggest the possibility of asymptotic methods for the solution of (1.69), although figure 1.9 itself shows no sign of any limiting behaviour (such as a relaxation oscillation).

The periodic orbit shown lies close to both nullclines, and this suggests a rescaling in the form

$$S = \frac{\psi}{\delta}, \quad (1.87)$$

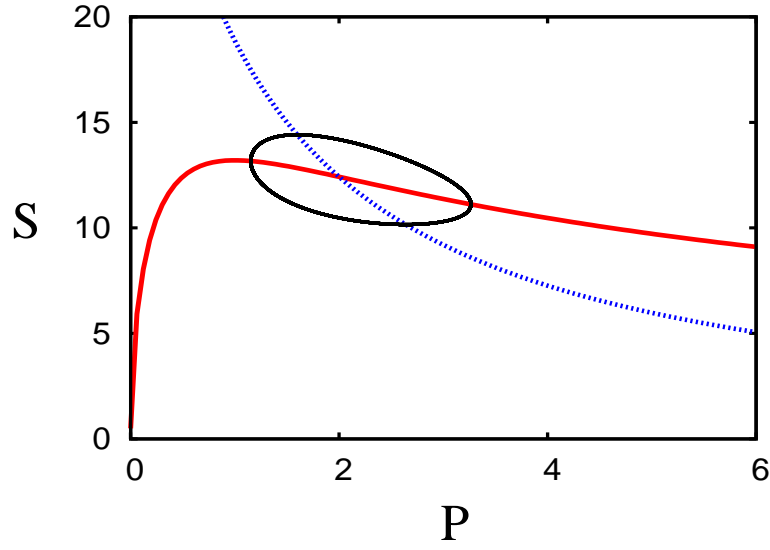

Figure 1.9: Limit cycle solution of (1.69) with  $\mu = 2$ ,  $K = 1$ ,  $L = 0.75 \times 10^7$ , and  $\beta = 10^4$ .

where

$$\delta = \sqrt{\frac{\beta}{L}} \ll 1. \quad (1.88)$$

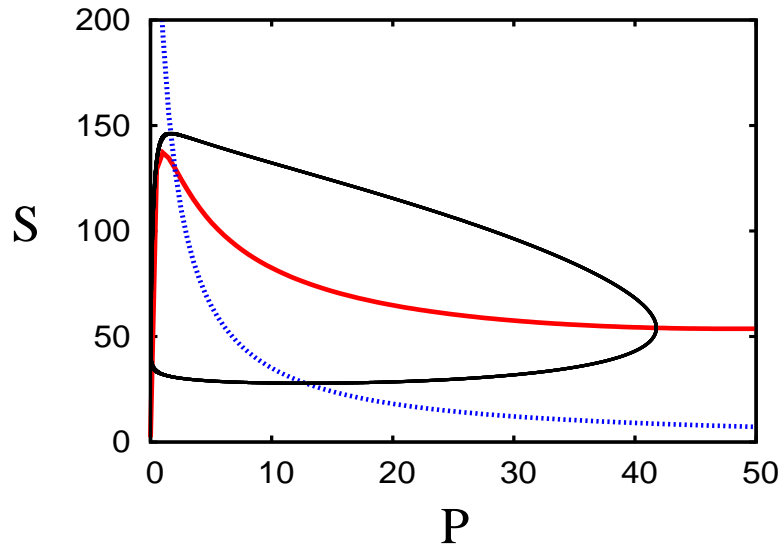

Figure 1.10: Limit cycle solution of (1.69) with  $\mu = 2$ ,  $K = 1$ ,  $L = 0.75 \times 10^7$ , and  $\beta = 10^2$ .



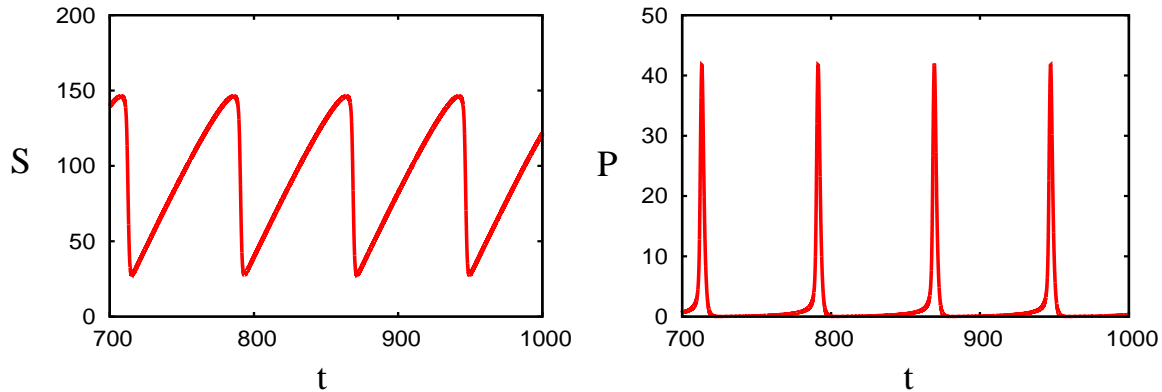

Figure 1.11: Time series for  $S$  and  $P$  in the solution of (1.69) with  $\mu = 2$ ,  $K = 1$ ,  $L = 0.75 \times 10^7$ , and  $\beta = 10^2$ , as in figure 1.10.

With this definition,

$$\phi = \frac{\psi(\psi + \delta)(1 + P)^2}{1 + \varepsilon(\psi + \delta)^2(1 + P)^2}, \quad (1.89)$$

where

$$\varepsilon = \frac{1}{\beta} \ll 1. \quad (1.90)$$

In addition, we rescale  $t \sim \frac{1}{\delta}$ , to find

$$\begin{aligned} \dot{\psi} &= \mu - \phi, \\ \delta \dot{P} &= -P + K\phi, \end{aligned} \quad (1.91)$$

and the overdot now denotes differentiation with respect to this rescaled time.

This is now in the classic form of a relaxation oscillation. Since  $\delta \ll 1$ , we expect  $P$  to relax rapidly to the  $P$ -nullcline, and since this curve has the classic pseudo-cubic shape (similar to the ‘slow manifold’ of the Van der Pol oscillator), we might expect a similar kind of switching behaviour. In reality, we can see from figure 1.9, for which the value of  $\delta \approx 0.04$ , that this behaviour is not attained. The orbit stays relatively close to the  $P$ -nullcline, but does not drift past the turning points.

However, if we reduce the value of  $\beta$  to  $10^2$ , for which  $\delta \approx 0.004$ , then the motion becomes more clearly relaxational, as shown in figures 1.10 and 1.11. The trajectory hugs the left part of the  $P$ -nullcline, but is unable to reach the right part, which lies in  $P \sim \beta \gg 1$ . (Further reduction of  $\beta$  does not help, since then the  $P$ -nullcline loses its non-monotonicity.) As seen in figure 1.11, the solution for  $S$  becomes relaxational, while that for  $P$  develops a series of isolated pulses.

It is easy to see that the slow branch of the oscillation where  $P$  is small is described by the quasi-steady approximation for (1.89) and (1.91), where we put  $\delta = 0$ . It is less obvious how to describe the rapid pulses of figure 1.11. Apparently,  $\psi$  remains

$O(1)$ , but  $P$  is large. If  $P \sim \beta = \frac{1}{\varepsilon}$  as we might expect, then  $\phi \approx \frac{1}{\varepsilon}$  is constant, and  $P$  would approach  $\beta K$ . Evidently, this is prevented in figure 1.10 by the fact that the trajectory crosses the  $P$ -nullcline.

We need to keep  $P$  and  $\phi$  the same size in the pulse, and this requires that formally  $\psi$  is small. It is not then difficult to show that a distinguished rescaling which keeps the  $P$ - $\phi$  balance in the  $P$  equation, while also allowing  $\psi$  to decrease on the same time scale, can be found by defining

$$\psi = \delta^{1/3}\Psi, \quad P = \frac{\Pi}{\delta^{2/3}}, \quad t = \delta T, \quad \phi = \frac{\Phi}{\delta^{2/3}}, \quad (1.92)$$

whence we obtain

$$\begin{aligned} \Psi' &= \delta^{2/3}\mu - \Phi, \\ \Pi' &= -\Pi + K\Phi, \end{aligned} \quad (1.93)$$

and  $\Phi$  is given by

$$\Phi = \frac{\Psi(\Psi + \delta^{2/3})(\Pi + \delta^{2/3})^2}{1 + \gamma(\Psi + \delta^{2/3})^2(\Pi + \delta^{2/3})^2}, \quad (1.94)$$

where

$$\gamma = \frac{\varepsilon}{\delta^{2/3}} = \frac{L^{1/3}}{\beta^{4/3}}; \quad (1.95)$$

for  $L = 0.75 \times 10^7$  and  $\beta = 10^2$ ,  $\gamma = 0.42$ . This rescaling is appropriate if  $\varepsilon \lesssim \delta^{2/3}$ , i. e.,  $L \lesssim \beta^4$ . Neglecting terms of  $O(\delta^{2/3})$ , we find that at leading order (1.93) reduces to

$$\begin{aligned} \Psi' &\approx -\frac{\Psi^2\Pi^2}{1 + \gamma\Psi^2\Pi^2}, \\ \Pi' &\approx -\Pi + \frac{K\Psi^2\Pi^2}{1 + \gamma\Psi^2\Pi^2}. \end{aligned} \quad (1.96)$$

Numerical simulations of (1.96) show that it gives a very good approximation to the pulse, providing the initial condition is chosen appropriately (for example, with  $S = 154$ ,  $P = 4$ ). Formally, the initial conditions must come from matching the pulse to the slow phase of the oscillation.

## 1.5 Notes and references

- Michaelis and Menten (1913)
- Briggs and Haldane (1925)

### 1.5.1 Boom and bust dynamics

Much of the discussion of glycolysis is based on the book by Goldbeter (1996). The form of the solutions shown in figure 1.11 are similar to many other situations in which pulse-like outbreaks occur: examples occur in the Lorenz equations, the delayed logistic equation, spruce budworm outbreaks, plankton booms and epidemics, as summarised by Fowler (2013, 2014). Many of these systems are described by equations analogous to (1.69), such as that of Omta *et al.* (2013), which describes paleoclimatic calcification spikes in the interaction between calcareous plankton (the product  $P$ ) and the ocean carbon reservoir (the substrate  $S$ ). Fowler (2014) showed that the asymptotic description for such boom-and-bust systems is associated with conditions of starvation. If we assume  $\mu \sim K \sim 1$ , then an appropriate rescaling of (1.69) is

$$t \sim \frac{1}{\varepsilon}, \quad S \sim \frac{1}{\varepsilon^2}, \quad \varepsilon = \left(\frac{\beta}{L}\right)^{1/4} \ll 1, \quad (1.97)$$

which leads to the rescaled system

$$\begin{aligned} \dot{S} &= \varepsilon(\mu - \phi), \\ \varepsilon \dot{P} &= -P + K\phi, \end{aligned} \quad (1.98)$$

where for (1.69) we would have

$$\phi \approx S^2(1 + P)^2, \quad (1.99)$$

assuming  $\beta \gg 1$ .

In situations where  $P$  represents a population, such as those considered by Omta *et al.* (2013) or Huppert *et al.* (2005), a simpler assumption is to take

$$\phi = SP, \quad (1.100)$$

and for this a simple characterisation of the solutions is possible (Fowler 2013, 2014). With (1.100), we define  $P = e^\theta$ , then  $KS = 1 + \varepsilon\dot{\theta}$ , and then  $\theta$  satisfies

$$\ddot{\theta} = \mu K - e^\theta(1 + \varepsilon\dot{\theta}), \quad (1.101)$$

which is the equation of a weakly damped oscillator. The oscillations take on the characteristics of the boom and bust oscillations at high values of the ‘energy’  $E = \frac{1}{2}\dot{\theta}^2 + V(\theta)$ , where the potential is  $V(\theta) = e^\theta - \mu K\theta$ . Fowler (2014) showed that two such competing populations could lead to self-sustained boom-and-bust oscillations. However, the form of (1.99) is not so conducive to such simple insights.

## Exercises

1.1 Derive a suitably scaled form of the Michaelis-Menten model for the reaction

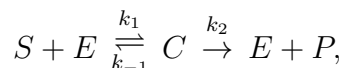

and show that it depends on the parameters

$$K = \frac{k_{-1} + k_2}{k_1 S_0}, \quad \lambda = \frac{k_2}{k_1 S_0}, \quad \varepsilon = \frac{E_0}{S_0},$$

where  $S_0$  and  $E_0$  are the initial values of  $S$  and  $E$ . If  $\varepsilon \ll 1$ , show that the solution consists of an outer layer in which  $t = O(1)$ , and an inner layer in which  $t = O(\varepsilon)$ , and find explicit approximations for these. Hence show that  $S$  decreases linearly initially, but exponentially at large times.

- 1.2 An enzyme has  $n$  binding sites for a substrate  $S$ . If the enzyme complexes with  $j$  bound sites are denoted as  $C_j$ , write down the rate equations for the concentrations of  $S$ ,  $P$  and  $C_j$ ,  $j = 0, 1, \dots, n$ , where  $C_0 = E$ , satisfying the reactions

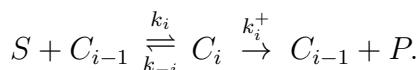

Deduce that

$$C_0 = E_0 - \sum_1^n C_i,$$

where  $E_0$  is the initial enzyme present. Use the quasi-steady state assumption to show that  $R_i = 0$ ,  $i = 1, \dots, n$ , where

$$R_i = k_i S C_{i-1} - (k_{-i} + k_i^+) C_i,$$

and deduce that the reaction rate  $r = dP/dt$  is given approximately by

$$r = \frac{E_0 \sum_{r=1}^n k_r^+ \phi_r S^r}{1 + \sum_{j=1}^n \phi_j S^j},$$

where

$$\phi_j = \prod_{i=1}^j \frac{1}{K_i}, \quad K_i = \frac{k_{-i} + k_i^+}{k_i}.$$

Deduce that if  $k_1 \rightarrow 0$  with  $k_1 k_n$  finite, the reaction rate is approximated by the Hill equation

$$r = \frac{k_n^+ E_0 S^n}{\prod_{i=1}^n K_i + S^n}.$$

- 1.3 A substrate  $S$  reacts with an enzyme to form a product  $P$  by the reaction scheme

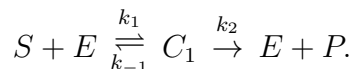

An inhibitor  $I$  prevents the reaction by binding to the enzyme, as

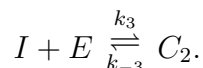

Use the quasi-steady state approximation to show that the rate of reaction is approximately

$$r = \frac{k_2 E_0 S K_i}{K_m I + K_i S + K_m K_i},$$

where

$$K_m = \frac{k_2 + k_{-1}}{k_1}, \quad K_i = \frac{k_{-3}}{k_3}.$$

If different initial values  $I_0, S_0$  are used, can a Lineweaver-Burk plot be used to find  $K_m, K_i$  and  $k_2$ ? Why, or why not?

- 1.4 Write a reaction scheme for the ATP-ADP reaction scheme indicated in figure 1.7, and described in figure 1.6.

By assuming that the enzyme reactions are in equilibrium, show that the fraction of bound sites on the enzyme is

$$Y = \frac{S(1+S)(1+P)^2}{L + (1+S)^2(1+P)^2},$$

where  $S = s/K_m, P = p/K_p, S$  and  $P$  are concentrations of substrate and product, and the constants  $K_m$  and  $K_p$  should be defined. Hence show that the effective rate of the reaction  $S \xrightarrow{r} P$  is

$$r = 2ke_0Y,$$

and define  $e_0$ .

If, as indicated in figure 1.7, S is produced at a rate  $v$ , while P is removed by first order decay with rate coefficient  $k_p$ , show that a suitable model is

$$\begin{aligned} \dot{s} &= v - r, \\ \dot{p} &= -k_p p + r, \end{aligned}$$

and show how to derive the dimensionless model

$$\begin{aligned} \dot{S} &= \mu - \phi(S, P), \\ \dot{P} &= -P + K\phi(S, P), \end{aligned}$$

where

$$\phi = \frac{\beta S(1+S)(1+P)^2}{L + (1+S)^2(1+P)^2},$$

and give the definitions of  $\mu, K, L$  and  $\beta$ .

- 1.5 [Oxford FHS 1997] What is meant by an *allosteric* enzyme?

Consider the model of the MWC dimer with two conformational states R and T, which consists of two protomers, each having a binding site for a substrate S.

Assuming T is inactive and cannot bind the substrate, explain why the kinetics of the enzyme system can be written as

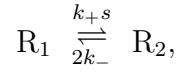
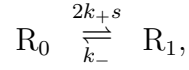
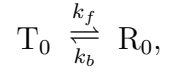

where  $s$  denotes the concentration of S.

Write down the rate equations for the concentrations of  $T_0$ ,  $R_0$ ,  $R_1$  and  $R_2$ , and by assuming a quasi-steady state, deduce that the fraction of bound S-sites is given by

$$Y = \frac{Q(1+Q)}{L+(1+Q)^2},$$

where

$$Q = \frac{k_+s}{k_-}, \quad L = \frac{k_b}{k_f}.$$

1.6 The  $S$ -nullcline of the glycolysis model is given by

$$\frac{\beta S(1+S)(1+P)^2}{L+(1+S)^2(1+P)^2} = \mu.$$

Assume that  $L \gg \beta \gg 1$  and that  $\mu \sim K \sim O(1)$ . Show that for  $1 \ll S \ll \sqrt{L}$ ,  $P \sim 1$ , the  $S$ -nullcline is given by

$$S \approx \left(\frac{\mu L}{\beta}\right)^{1/2} \frac{1}{1+P},$$

and show that this approximation remains valid until  $P \sim \left(\frac{L}{\beta}\right)^{1/2}$ .

The  $P$ -nullcline is given by

$$\frac{\beta S(1+S)(1+P)^2}{L+(1+S)^2(1+P)^2} = \frac{P}{K}.$$

Show that with the same assumptions for  $S$  and  $P$ , this is approximately

$$S \approx \left(\frac{L}{\beta K}\right)^{1/2} \frac{\sqrt{P}}{1+P}.$$

Hence show that the local maximum of this curve at  $U$  is given by  $P \approx 1$ ,

$$S \approx \left(\frac{L}{4\beta K}\right)^{1/2}.$$

Show that the above approximation for the  $P$ -nullcline breaks down when  $S \sim \frac{\sqrt{L}}{\beta}$  and  $P \sim \beta$ . If we write  $\lambda = \frac{L}{\beta^2}$  and  $P = \beta\Pi$ , show that if  $\lambda = O(1)$  then  $\Pi$  is given by

$$\Pi = \frac{KS \pm \{K^2S^2 - 4\lambda\}^{1/2}}{2(1+S)}$$

(and  $S = O(1)$ ), and deduce that the minimum of the  $P$ -nullcline at  $V$  is given by  $S \approx \frac{2\sqrt{L}}{\beta K}$ ,  $P \approx \frac{\beta KS}{2(1+S)}$ .

# Chapter 2

## Trans-membrane ion transport

### 2.1 Membrane transport

The cell membrane is a *phospholipid double layer* about 7.5nm thick separating the cell interior (the *cytoplasm*) from the extracellular environment (see figure 2.1). The term *lipid* refers to a class of water-insoluble, energy-rich macromolecules, typically fats, waxes and oils. The most important property of the cell membrane is its selective permeability; it allows the passage of some molecules but restricts the passage of others, thereby regulating the passage of materials into and out of the cell.

The membrane contains water-filled pores with diameters of about 0.8nm, and protein-lined pores, called *channels* or *gates*, which allow the passage of specific molecules. Both the intracellular and extracellular environments comprise (among other things) a dilute aqueous solution of dissolved salts, mainly NaCl and KCl, which dissociate into  $\text{Na}^+$ ,  $\text{K}^+$  and  $\text{Cl}^-$  ions. The cell membrane acts as a barrier to the free flow of these ions and to the flow of water.

The many mechanisms that exist for transporting molecules from one side of the membrane to the other can be divided up into active and passive processes. An active process is one which requires the expenditure of energy (for example, convection), while a passive process is one which results solely from the random motion of molecules (for example, diffusion).

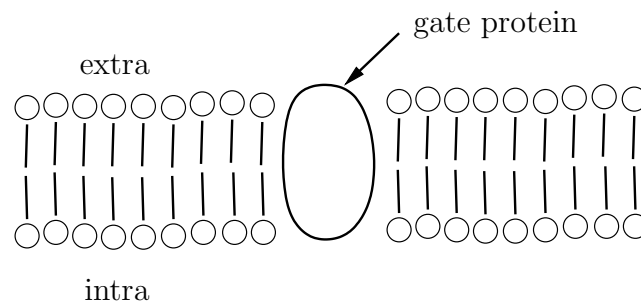

Figure 2.1: Schematic diagram of the cell membrane



	extra	intra
Na <sup>+</sup>	437	50
K <sup>+</sup>	20	397

Table 2.1: Typical intracellular and extracellular ionic concentrations for the squid giant axon. Units are mM = millimolar =  $10^{-3}$ M. 1M = 1 molar = 1 mole litre<sup>-1</sup>.

Passive mechanisms by which molecules are transported across the cell membrane include osmosis, diffusion, and carrier-mediated mechanisms. *Osmosis* is the mechanism by which water is transported across the cell membrane. Small molecules such as chloride ions may diffuse through pores in the membrane, while lipid-soluble molecules such as oxygen and carbon dioxide may diffuse directly through the membrane itself. *Carrier-mediated diffusion* refers to a process by which a molecule “hitches a lift” by binding to a carrier molecule which is lipid soluble and can move readily through the membrane. *Carrier-mediated transport* occurs when a protein which sits in the membrane has an active site which may be exposed either on the exterior or interior side of the membrane depending on the conformational state of the protein. A substrate may bind to the protein in one conformation, the protein undergoes a conformational change, and the substrate unbinds on the other side of the membrane. The transport of glucose and amino acids across the cell membrane is thought to be by a carrier-mediated process.

The concentration differences that exist between the intracellular and extracellular environments are set up and maintained by active processes. One of the most important of these is the Na<sup>+</sup>-K<sup>+</sup> pump, which uses the energy stored in ATP molecules to pump Na<sup>+</sup> out of the cell and K<sup>+</sup> in. There are also a variety of exchange pumps, which use the concentration gradient of one ion to pump another ion against its concentration gradient, such as the Na<sup>+</sup>-Ca<sup>2+</sup> exchanger, which removes Ca<sup>2+</sup> from the cell at the expense of allowing Na<sup>+</sup> in. Differences in interior and exterior ionic concentrations create a potential difference across the cell which also drives an ionic current down ion-specific membrane channels. Typical intracellular and extracellular ionic concentrations are shown in Table 2.1.

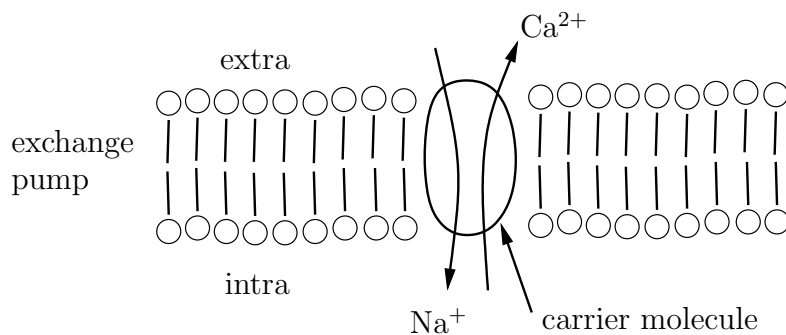

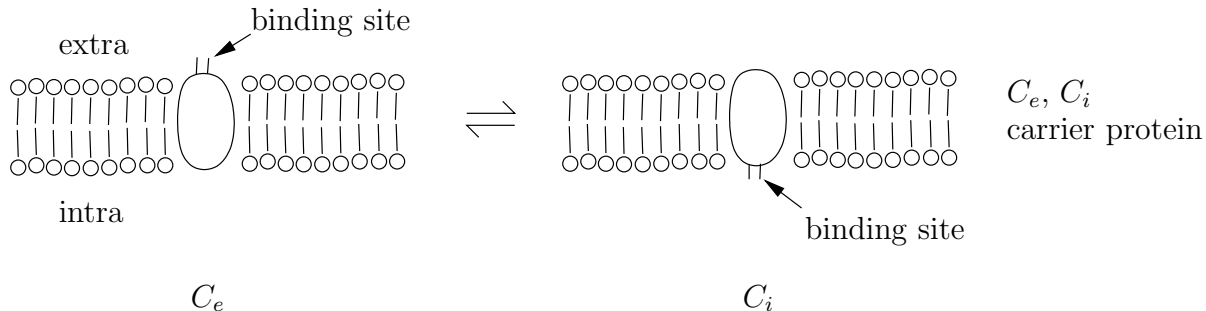
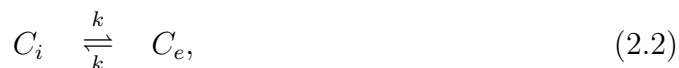
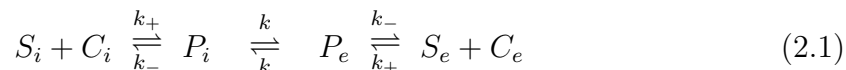

Figure 2.2: A schematic representation of carrier mediated transport

### 2.1.1 Carrier mediated transport

We describe here a simple model for carrier mediated transport. We suppose that the carrier protein has two conformational states, and that in the first state, labelled  $C_i$ , the substrate binding site is exposed on the cell interior, while in the second state, labelled  $C_e$ , the substrate binding site is exposed on the cell exterior (see Figure 2.2). We suppose that substrate molecules outside the cell (concentration  $S_e$ ) can bind to  $C_e$  to produce a complex  $P_e$ , and that substrate molecules inside the cell (concentration  $S_i$ ) can bind to  $C_i$  to produce a complex  $P_i$ . Furthermore, we assume that  $P_i$  can conformally change into  $P_e$  and vice versa, and at the same rate as the conformal changes of  $C_i$  and  $C_e$  (so that the binding of the substrate does not affect the conformal changes of the protein). Thus the reaction scheme is



where we have assumed that the binding affinity of  $S_i$  to  $C_i$  is the same as that of  $S_e$  to  $C_e$ , and that the two conformational states  $C_i$  and  $C_e$  are equally likely. To avoid the system simply settling down to a steady state with zero flux, we assume that the substrate is supplied at a constant rate  $J$  on the exterior and taken away at the same rate from the interior, and we wish to determine this flux of substrate through the membrane as a function of the interior and exterior concentrations.

Using the law of mass action the reaction kinetics are given by

$$\frac{dS_i}{dt} = k_-P_i - k_+S_iC_i - J, \quad (2.3)$$

$$\frac{dS_e}{dt} = k_-P_e - k_+S_eC_e + J, \quad (2.4)$$

$$\frac{dP_i}{dt} = kP_e - kP_i + k_+S_iC_i - k_-P_i, \quad (2.5)$$

$$\frac{dP_e}{dt} = kP_i - kP_e + k_+S_eC_e - k_-P_e, \quad (2.6)$$

$$\frac{dC_i}{dt} = kC_e - kC_i - k_+S_iC_i + k_-P_i, \quad (2.7)$$

$$\frac{dC_e}{dt} = kC_i - kC_e - k_+S_eC_e + k_-P_e. \quad (2.8)$$

Adding (2.5)-(2.8) gives

$$\frac{d}{dt}(P_i + P_e + C_i + C_e) = 0,$$

so that

$$P_i + P_e + C_i + C_e = C_0 = \text{constant}, \quad (2.9)$$

i.e. the total amount of carrier is conserved. Adding (2.3)-(2.6) gives

$$\frac{d}{dt}(S_i + S_e + P_i + P_e) = 0,$$

so that

$$S_i + S_e + P_i + P_e = S_0 = \text{constant}, \quad (2.10)$$

i.e. the total amount of substrate is conserved. In the steady state, assuming  $J$  is unknown, we have 6 equations for 7 unknowns, so that there is a one parameter family of solutions, even when  $C_0$  and  $S_0$  are given. However, solving the linear system (2.4)-(2.7) and (2.9) for  $J$ ,  $P_i$ ,  $P_e$ ,  $C_i$ ,  $C_e$  in terms of  $S_i$  and  $S_e$  gives

$$J = \frac{k_-kC_0}{2k_+} \frac{S_e - S_i}{(K_m + S_i)(K_m + S_e) - K_d^2}, \quad (2.11)$$

where

$$K_m = \frac{k_- + k}{k_+}, \quad K_d = \frac{k}{k_+}.$$

There are also other, more complicated, mechanisms for carrier-mediated transport. The carrier molecule may have binding sites for more than one substrate molecule, leading to cooperative behaviour and more complicated kinetics. It may also have binding sites for different types of substrate molecules. These different substrates may both be transported across the membrane in the same direction (*symport transporters*), or may be transported in opposite directions (*antiport transporters*). A key assumption in modelling such transporters is that the carrier may only undergo

the conformational change when either all or none of the substrate molecules are bound. While the different states of the carrier and the transitions between them are easy to write down, the resulting system of equations is sufficiently large that the expression for the flux as a function of concentration is very complicated.

### 2.1.2 Active transport: the sodium-potassium pump

The carrier-mediated transport described above moves molecules down chemical gradients. Any process which move molecules against a chemical or electrical gradient requires the expenditure of energy, and is known as an active transport mechanism. One of the most important of these is the  $\text{Na}^+-\text{K}^+$  pump, which pumps sodium ions out of the cell against a steep electrochemical gradient, while pumping potassium ions in. In fact, this pump alone consumes almost a third of the energy requirement of a typical animal cell.

The pump uses the energy stored in ATP which is released when it is dephosphorylated into ADP, through the overall reaction scheme



where the subscripts  $i$  and  $e$  denote intracellular and extracellular ions respectively. The individual components of the reaction are thought to be as follows. When the carrier protein ( $\text{Na}^+-\text{K}^+$ ATPase) is in its dephosphorylated state, three sodium binding sites are exposed to the cell's interior. When all three binding sites are filled, the carrier protein is phosphorylated by the hydrolysis of ATP into ADP. This phosphorylation induces a change in conformation, so that the sodium binding sites are exposed to the cell exterior, and their binding affinity is reduced, causing the release of the sodium ions. At the same time, two potassium sites are exposed to the cells exterior. When potassium ions have bound to these two sites, the carrier protein is dephosphorylated, inducing the reverse conformational change, exposing the potassium binding sites to the cell interior and reducing the binding affinity so that potassium is released. If we simplify the process slightly, assuming that there is a single binding site for sodium and potassium, leading to a one-for-one exchange rather than the three-for-two which actually happens, then the detailed reaction scheme is

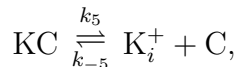
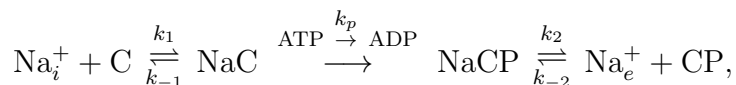

where the carrier protein is represented by C in its unphosphorylated, unbound state, CP in its phosphorylated unbound state, NaC when bound to sodium and unphosphorylated, NaCP when bound to sodium and phosphorylated, KC when bound to

potassium and unphosphorylated, and KCP when bound to potassium and phosphorylated. Using mass action kinetics, assuming that intracellular potassium and extracellular sodium are removed at a constant rate  $J$ , leads to a steady-state flow of ions through the pump

$$J = \frac{J_0 [\text{Na}_i^+][\text{K}_e^+]}{[\text{Na}_i^+] + \alpha[\text{K}_i^+] + \beta[\text{K}_e^+]} \quad (2.12)$$

where

$$J_0 = \frac{C_0 k_3 k_4 k_5}{k_{-3} k_{-3} [\text{P}] + k_{-3} k_5 + k_4 k_5},$$

$$\alpha = \frac{(k_{-1} k_p + k_2 k_{-1} + k_2 k_p) k_{-3} k_{-4} k_{-5}}{k_1 k_2 k_p (k_{-3} k_{-3} [\text{P}] + k_{-3} k_5 + k_4 k_5)}, \quad \beta = \frac{(k_{-1} k_p + k_2 k_{-1} + k_2 k_p) k_3 k_4 k_5}{k_1 k_2 k_p (k_{-3} k_{-3} [\text{P}] + k_{-3} k_5 + k_4 k_5)},$$

where  $C_0$  is the total concentration of carrier molecule, and  $[\text{Na}_e^+]$  denotes the concentration of sodium ions in the extracellular medium, etc. The important thing to note is that for both carrier-mediated transport (2.11) and active transport (2.12) pump fluxes have the same features as enzyme catalysed reactions, that is, they are linear in the concentrations at small concentrations, but saturate to a maximum value at large concentrations.

### 2.1.3 The membrane potential

The differences in the concentration of various ions between the extracellular and intracellular medium which are set up and maintained by active transport mechanisms can cause a potential difference to be generated between the inside and the outside of the cell.

Suppose we have two reservoirs containing different concentrations of a positively charged ion  $X^+$ . We suppose both reservoirs are electrically neutral to begin with, so that there is an equal concentration of a negatively charged ion  $Y^-$ . Now suppose the reservoirs are separated by a semi-permeable membrane which is permeable to  $X^+$  but not to  $Y^-$ . Then the difference in concentration of  $X^+$  on each side will lead to the flow of  $X^+$  across the membrane. However, because  $Y^-$  cannot diffuse through the membrane this will lead to a build up of charge on one side. This charge imbalance sets up an electric field, which produces a force on the ions opposing further diffusion of  $X^+$ . It is important to realise that the actual amount of  $X^+$  which diffuses through the membrane is small, and the excess charge all accumulates near the interface, so that to a good approximation the solutions on either side remain electrically neutral. The potential difference at which equilibrium is established and diffusion and electric-field-generated fluxes balance is known as the *Nernst potential*. We may derive an expression for it as follows.

If  $c$  denotes the concentration of an ion S then the flux of ions due to diffusion is  $\mathbf{J} = -D\nabla c$ , where  $D$  is the diffusion coefficient. To this we must add the flux due to the fact that the ion carries a charge and is in the presence of an electric field, which is given by

$$\mathbf{J} = -\frac{uzc}{|z|} \nabla \phi,$$

where  $u$  is the mobility of the ion (defined as the velocity under a constant unit electric field),  $z$  is the valence of the ion (so that  $z/|z|$  is either  $+1$  or  $-1$  and gives the sign of the force on the ion; positive ions move down potential gradients, negative ions move up potential gradients), and  $\phi$  is the electric potential, so that  $-\nabla\phi$  is the electric field. Thus the total flux is given by

$$\mathbf{J} = -D\nabla c - \frac{uzc}{|z|}\nabla\phi. \quad (2.13)$$

Now, there is a relationship (determined by Einstein) between the ionic mobility and the diffusion coefficient, which is

$$D = \frac{uRT}{|z|F},$$

where  $R$  is the universal gas constant,  $T$  is the temperature and  $F$  is Faraday's constant. Furthermore, since the membrane is thin we can replace the Nernst-Planck equation (2.13) with the one-dimensional version

$$J = -D \left( \frac{dc}{dx} + \frac{zFc}{RT} \frac{d\phi}{dx} \right), \quad (2.14)$$

where  $x$  is a coordinate normal to the membrane. Now, at equilibrium the flux  $J$  is zero, giving

$$\frac{dc}{dx} + \frac{zFc}{RT} \frac{d\phi}{dx} = 0,$$

or equivalently

$$\frac{1}{c} \frac{dc}{dx} + \frac{zF}{RT} \frac{d\phi}{dx} = 0.$$

Assuming that the interior of the membrane is at  $x = 0$  while the exterior is at  $x = L$ , we may integrate from 0 to  $L$  to give

$$[\log c]_0^L + \frac{zF}{RT} [\phi]_0^L = 0,$$

i.e.

$$\phi_i - \phi_e = \frac{RT}{zF} \log \left( \frac{c_e}{c_i} \right), \quad (2.15)$$

where the subscripts  $e$  and  $i$  denote extracellular and intracellular quantities respectively. If we follow the standard convention of defining the potential difference across the cell membrane as  $V = \phi_i - \phi_e$ , then the Nernst potential for S is

$$V_S = \frac{RT}{zF} \log \frac{c_e}{c_i} = \frac{RT}{zF} \log \frac{[S_e]}{[S_i]}.$$

Using the values of intra and extracellular concentrations given in Table 2.1, typical Nernst potentials for the squid giant axon for potassium and sodium are  $V_K = -77$  mV

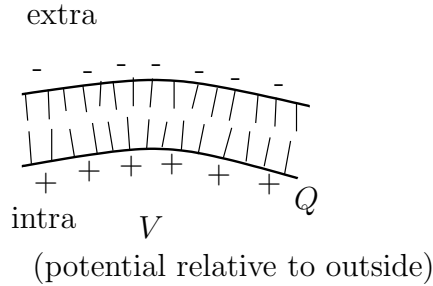

Figure 2.3: Schematic diagram of the build up of charge on the cell membrane

(millivolt) and  $V_{\text{Na}} = 56 \text{ mV}$ . Note that when more than one ion is present, and they have different Nernst potentials, the flux of each individual ion will not be zero even when there is no net current across the membrane. For example, when  $-77 \text{ mV} < V < 56 \text{ mV}$  there will be a flux of  $\text{K}^+$  out of the cell and  $\text{Na}^+$  into the cell through ion-specific channels. This flux is balanced by the action of the  $\text{Na}^+\text{-K}^+$  pump.

### 2.1.4 Ionic currents

We have seen that the flow of ions through the cell membrane due to concentration differences leads to a build up of charge near the membrane and a potential difference (see Figure 2.3). Thus the cell membrane is effectively acting as a capacitor. The voltage across any capacitor is related to the charge stored  $Q$  by

$$V = \frac{Q}{C},$$

where  $C$  is the capacitance. If  $I$  is the ionic current out of the cell (the rate of flow of positive charges outwards) then the stored charge changes according to

$$I = -\frac{dQ}{dt}.$$

Thus, assuming the capacitance is constant,

$$C \frac{dV}{dt} + I = 0. \tag{2.16}$$

This equation is the basis for much theoretical electrophysiology. The difference between the various models arises in the expression used for the ionic current  $I$ .

The simplest model to use is to assume a linear dependence of  $I$  on  $V$  (as in Ohms law). For a single ion  $S$ , with Nernst potential  $V_S$ , this gives an ionic current

$$I_S = g_S(V - V_S),$$

where the constant  $g_S$  is the ion-specific membrane conductance, since the current must be zero when  $V = V_S$ . If more than one ion is present the currents from different ions are simply added together to produce the total ionic current  $I$ .

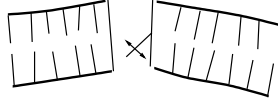

Figure 2.4: Schematic diagram of channel gating

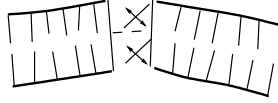
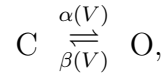

Figure 2.5: A channel with two identical gate units

### 2.1.5 Gating

It is found experimentally that  $g_S$  is not constant depends on both  $V$  and time  $t$ . One proposed explanation for this is that the channels are not always open, but may be open or closed, and that the transition rates between open and closed states depend on the potential difference  $V$  (see Figure 2.4). The membrane conductance may then be written as  $ng_S$ , where  $g_S$  is the constant conductance which would result if all channels were open, and  $n$  is the proportion of open channels.

Denoting the open channels by O and the closed channels by C, the reaction scheme is simply



giving

$$\frac{dn}{dt} = \alpha(V)(1 - n) - \beta(V)n, \quad (2.17)$$

or equivalently

$$\tau_n(V) \frac{dn}{dt} = n_\infty(V) - n. \quad (2.18)$$

where  $n_\infty(V) = \alpha/(\alpha + \beta)$  is the equilibrium value of  $n$  and  $\tau_n(V) = 1/(\alpha + \beta)$  is the timescale for approach to this equilibrium. Both  $n_\infty$  and  $\tau_n$  can be determined experimentally.

### 2.1.6 Multiple gates

The simple model presented in Section 2.1.5 can be generalised to channels which contain multiple identical subunits, each of which can be in either the open or closed state (see Figure 2.5). If we let  $S_i$  denote the density of states with  $i$  open gates then the transition between channel states is governed by the reaction scheme

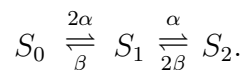



The 2's arise because there are two possible states with one gate open and one gate closed. Since each gate is identical we have lumped these two states into one variable  $S_1$ . Using mass action kinetics gives

$$\frac{dS_0}{dt} = \beta S_1 - 2\alpha S_0, \quad (2.19)$$

$$\frac{dS_2}{dt} = \alpha S_1 - 2\beta S_2. \quad (2.20)$$

We could write down an equation for  $S_1$  also, but this equation is superfluous since  $S_1$  can be determined from the conservation of channels

$$S_0 + S_1 + S_2 = 1. \quad (2.21)$$

Simple substitution shows that (2.19)-(2.21) are satisfied by

$$S_0 = (1 - n)^2, \quad S_1 = 2n(1 - n), \quad S_2 = n^2, \quad (2.22)$$

providing

$$\frac{dn}{dt} = \alpha(1 - n) - \beta n. \quad (2.23)$$

Thus  $n$  satisfies the differential equation (2.17) for a single gate, and the proportion of open channels is  $n^2$ .

Equation (2.23) is a first order equation, whereas (2.19)-(2.21) is a second order system. Thus not all solutions to (2.19)-(2.21) are of the form (2.22); only if the initial conditions are compatible with (2.22) will the solution be of this form. However, if we write

$$\begin{aligned} S_0 &= (1 - n)^2 + y_0, \\ S_1 &= 2n(1 - n) - y_0 - y_2, \\ S_2 &= n^2 + y_2, \end{aligned}$$

then  $y_0, y_2$  satisfy

$$\begin{aligned} \frac{dy_0}{dt} &= -2\alpha y_0 - \beta(y_0 + y_2), \\ \frac{dy_2}{dt} &= -\alpha(y_0 + y_2) - 2\beta y_2. \end{aligned}$$

This linear system of equations has eigenvalues  $-(\alpha + \beta)$ ,  $-2(\alpha + \beta)$  so that  $y_0, y_2$  decay exponentially to zero. Thus even if an initial condition not compatible with (2.22) is given, the solution will still approach exponentially that given by (2.22)-(2.23) (that is, (2.22)-(2.23) defines a stable invariant manifold of the full system (2.19)-(2.21)).

The analysis of a two-gated channel above generalises easily to channels containing more gates. In the case of  $k$  identical gates the fraction of open channels is  $n^k$ , where  $n$  again satisfies (2.23).

### 2.1.7 Non-identical gates

Often channels are controlled by more than one protein, with each protein controlling a set of identical gates, but with the gates of each protein different and independent. Consider, for example, the case of a channel with two types of gate,  $m$  and  $h$  say, each of which may be open or closed. If  $S_{ij}$  denotes a channel with  $i$  open gates of type  $m$  and  $j$  open gates of type  $h$ , then the reaction scheme is

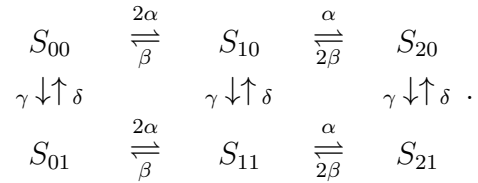

Simple substitution shows that the rate equations are satisfied by

$$\begin{aligned}
 S_{00} &= (1 - m)^2(1 - h), & S_{10} &= 2m(1 - m)(1 - h), & S_{20} &= m^2(1 - h), \\
 S_{01} &= (1 - m)^2h, & S_{11} &= 2m(1 - m)h, & S_{21} &= m^2h,
 \end{aligned}$$

so that the proportion of open channels is  $m^2h$ , providing

$$\frac{dm}{dt} = \alpha(1 - m) - \beta m, \tag{2.24}$$

$$\frac{dh}{dt} = \gamma(1 - h) - \delta h. \tag{2.25}$$

As before, the not all solutions of the rate equations (which form a fifth-order system) are solutions of the second order system (2.24)-(2.25). However, such solutions again form a stable invariant manifold.

## 2.2 Hodgkin-Huxley model

The nervous system is a communication system formed by nerve cells called *neurons*. Information is propagated along long cylindrical segments called *axons* by electrochemical signals.

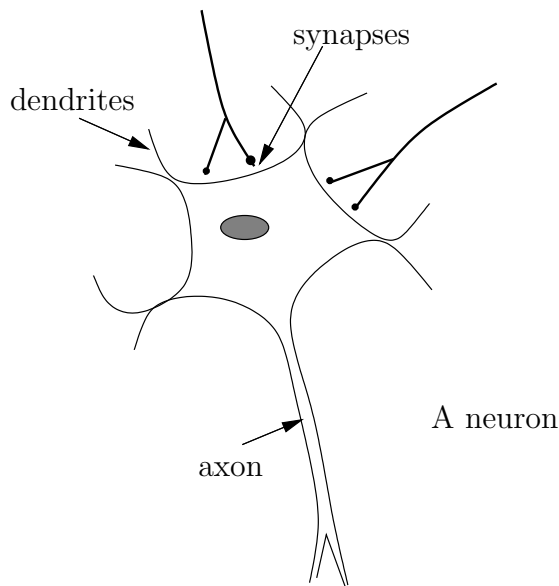

An important property of neurons is *excitability*. If small current is applied to the cell for a short time, then the membrane potential changes slightly, but returns directly to its equilibrium potential (the *resting potential*) once the applied current is removed. However, if a sufficiently large current is applied for a short time the membrane potential undergoes a large excursion (called an *action potential*) before returning to its resting value. It is by the propagation of such action potentials along the axons of neurons that signals are transmitted.

In Chapter 3 we will consider the propagation of an action potentials along the axon. In building up to that model we first consider here the Hodgkin-Huxley model of the excitability of an axon without the extra complication of spatial variation in the membrane potential. Such a situation can be realised experimentally by inserting a thin electrode along the centre of the axon, which acts to short-circuit the cell and keep the membrane potential  $V$  constant along its length (this is known as the space clamp technique).

If we suppose that we are applying an external inward current  $I$  to the cell, then the total outward current is  $I_i - I$ , where  $I_i$  is the outward ionic current as before. Then equation (2.16) gives

$$I = I_i + C_m \frac{dV}{dt},$$

where  $C_m$  is the membrane capacitance. In the giant squid axon, as in many neurons, the most important ionic currents are due to the motion of sodium and potassium ions. Experimentally it is found that the potassium conductance may be modelled by a gated channel of the form described in Section 2.1.5 with an exponent of 4, that is, the conductance is  $g_K n^4$  where

$$\tau_n(V) \frac{dn}{dt} = n_\infty(V) - n.$$

While this seems to imply that the potassium channel is controlled by a protein with four identical gates, it should be noted that the exponent is determined as a

reasonable fit to measured ionic currents, and not from any detailed physiological knowledge of the potassium channel itself. The equilibrium value  $n_\infty$  is found to be an increasing function of  $V$ . Thus at elevated potentials  $n$  is increased, thereby turning on, or *activating*, the potassium current. The Nernst potential for potassium is below the resting potential, so that the potassium current is an outward current at potentials greater than the resting potential. The function  $n(t)$  is called the potassium activation.

For the sodium conductance experimental data suggests that there are two processes at work, one which turns on the sodium current and one which turns it off. The model of Hodgkin-Huxley assumes a channel controlled by two proteins, with a conductance of the form  $g_{\text{Na}}m^3h$  where

$$\begin{aligned}\tau_m(V)\frac{dm}{dt} &= m_\infty(V) - m, \\ \tau_h(V)\frac{dh}{dt} &= h_\infty(V) - h.\end{aligned}$$

Again, while this seems to imply a channel with three  $m$  gates and one  $h$  gate, the exponents are determined as a reasonable fit to measured ionic currents, and not from a detailed knowledge of the sodium channel itself. At the resting potential  $m_\infty$  is small and  $h_\infty$  is close to one. For elevated potentials  $h_\infty$  decreases and  $m_\infty$  increases. Thus  $m$  is called the *sodium activation*, and  $h$  is called the *sodium inactivation*. The Nernst potential for sodium is above the resting potential, so that the potassium current is an inward current at potentials greater than rest.

The Hodgkin-Huxley model is

$$I_i = \underbrace{g_{\text{Na}}m^3h(V - V_{\text{Na}})}_{\text{Na}^+ \text{ current, activation-inactivation}} + \underbrace{g_{\text{K}}n^4(V - V_{\text{K}})}_{\text{K}^+ \text{ current}} + \underbrace{g_{\text{L}}(V - V_{\text{L}})}_{\text{leakage (other ions, e.g. Cl}^-)}.$$

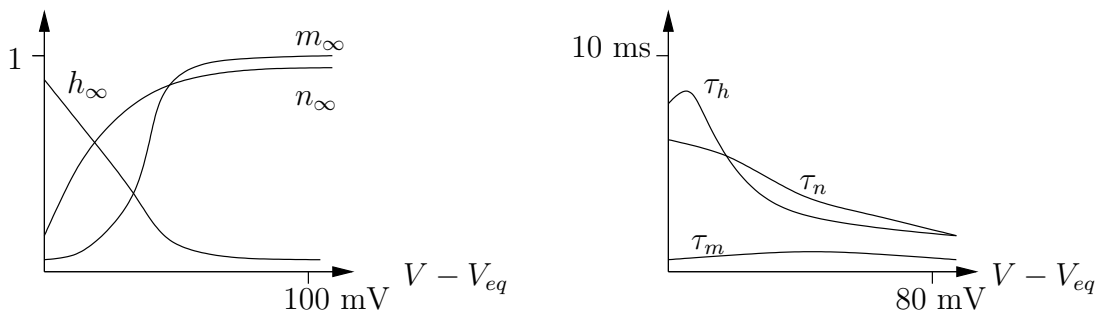

The membrane is *excitable*. The *resting potential*

$$V_{eq} \approx -70\text{mV}$$

is stable, but a finite perturbation causes an excursion called an *action potential*.

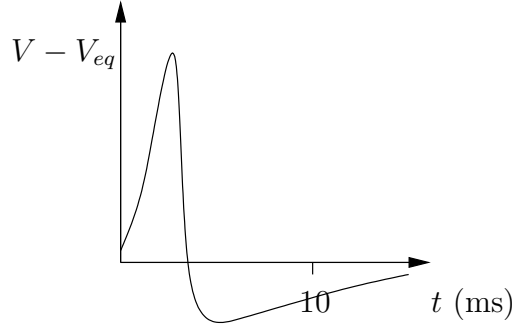

Note that

$$C_m \frac{dV}{dt} = I - (g_{\text{Na}} m^3 h + g_{\text{K}} n^4 + g_L) (V - V_{eq})$$

$$V_{eq} = \frac{(g_{\text{Na}} m^3 h V_{\text{Na}} + g_{\text{K}} n^4 V_{\text{N}} + g_L V_L)}{(g_{\text{Na}} m^3 h + g_{\text{K}} n^4 + g_L)}$$

so the time constant for  $V$  is

$$\tau_V = \frac{C_m}{g_{\text{Na}} m^3 h + g_{\text{K}} n^4 + g_L} \approx 1 \text{ms}.$$

Therefore  $\tau_m \ll \tau_V \ll \tau_n \sim \tau_h$ .

Thus: increase  $V \Rightarrow$  increase  $m$  rapidly ( $\text{Na}^+$  gates open).  $\text{Na}^+$  floods in  $\Rightarrow V$  increases until  $h$  gets deactivated and  $\text{K}^+$  gate opens  $\Rightarrow V$  decreases again followed by slow recovery.

## 2.3 FitzHugh-Nagumo equation

A simple model. Write  $V - V_{eq} = v$ .  $\tau_m$  is small  $\Rightarrow m \approx m_\infty(v)$ .

$$\tau_n \frac{dn}{dt} = n_\infty - n,$$

$$\tau_h \frac{dh}{dt} = h_\infty - h.$$

Assume  $\tau_n \approx \tau_h$  and note  $n_\infty + h_\infty \approx \text{constant} = \bar{h}$  say ( $\approx 0.8$  in practice). Then

$$\tau_n \frac{d}{dt} (n + h) \approx \bar{h} - (n + h) \Rightarrow n + h \equiv \bar{h}.$$

Then we obtain a 2-D model

$$C_m \frac{dV}{dt} = I - (g_{\text{K}} (v - v_{\text{K}}) n^4 + g_{\text{Na}} (v - v_{\text{Na}}) m^3(v) (\bar{h} - n) + g_L (v - v_L)),$$

$$\tau_n(v) \frac{dn}{dt} = n_\infty(v) - n.$$

Experimental values of  $v_{\text{K}} = V_{\text{K}} - V_{eq}$  etc are

$$\begin{aligned}
g_{\text{Na}} &= 120 & g_{\text{K}} &= 36 & g_L &= 0.3 & \text{mS cm}^{-2} & (1 \text{ S} = 1 \text{ Siemens}) \\
v_{\text{Na}} &= 115 & v_{\text{K}} &= -12 & v_L &= 10.6 & & \text{mV} \\
V_{\text{Na}} &= 45 & V_{\text{K}} &= -82 & V_L &= -60 & & V_{eq} = -70\text{mV} \\
C_m &\approx 1\mu\text{F cm}^{-2}.
\end{aligned}$$

$$\text{Units} \left[ \begin{array}{l} 1 \text{ C (coulomb)} = \text{unit of charge} \\ 1 \text{ A (amp)} = 1 \text{ C s}^{-1} \\ 1 \text{ VA (volt-ampere)} = 1 \text{ W (watt)} = 1 \text{ J s}^{-1} \\ 1 \text{ F (farad)} = 1 \text{ C V}^{-1} \\ 1 \Omega \text{ (ohm)} = 1 \text{ V A}^{-1} \\ 1 \text{ S (siemens)} = 1 \Omega^{-1} = 1 \text{ F s}^{-1} \end{array} \right]$$

**Non-dimensionalise**  $v \sim v_{\text{Na}}$ ,  $t \sim \tau_n = 5\text{ms}$ , (taken as constant)  $\Rightarrow$

$$\begin{aligned}
\frac{dn}{dt} &= n_{\infty}(v) - n, \\
\varepsilon \frac{dv}{dt} &= I^* - g(v, n)
\end{aligned}$$

$$\begin{aligned}
I^* &= \frac{I}{g_{\text{Na}}v_{\text{Na}}}, & g(v, n) &= \gamma_{\text{K}}(v + v_{\text{K}}^*)n^4 + \gamma_L(v - v_L^*) - (1 - v)(\bar{h} - n)m^3(v) \\
\gamma_{\text{K}} &= \frac{g_{\text{K}}}{g_{\text{Na}}} \sim 0.3, & \gamma_L &= \frac{g_L}{g_{\text{Na}}} \sim 0.003, & v_{\text{K}}^* &= -\frac{v_{\text{K}}}{v_{\text{Na}}} \sim 0.1, & v_L^* &= \frac{v_L}{v_{\text{Na}}} \sim 0.1, \\
\varepsilon &= \frac{C_m}{g_{\text{Na}}\tau_n} \sim 0.2 \times 10^{-2}.
\end{aligned}$$

At rest state

$$\begin{aligned}
n \sim 0.3, \quad m \sim 0.05, \quad h \sim 0.5 &\Rightarrow n^4 \sim 10^{-2}, \quad m^3 \sim 10^{-4} \\
\left. \begin{array}{l} \gamma_{\text{K}}v_{\text{K}}^*n^4 \sim 0.3 \times 10^{-3} \\ -\gamma_Lv_L^* \sim -0.3 \times 10^{-3} \\ (\bar{h} - n)m^3 \sim 0.5 \times 10^{-4} \end{array} \right\} \rightarrow \text{give rest state } v \approx 0 \text{ not } v \approx -v_{\text{K}}^*
\end{aligned}$$

$\varepsilon \ll 1 \Rightarrow v$  is a fast variable. Neglect  $\gamma_L$ . Take  $I^* = 0$ . Then  $g \rightarrow 0$  rapidly.

Nullclines: curves on which  $dn/dt = 0$  and  $dv/dt = 0$ . For  $v$  order one neglect  $\gamma_L$ . Then  $g = 0$  when

$$\frac{n^4}{\bar{h} - n} \approx \frac{(1 - v)m^3(v)}{\gamma_{\text{K}}(v + v_{\text{K}}^*)}$$

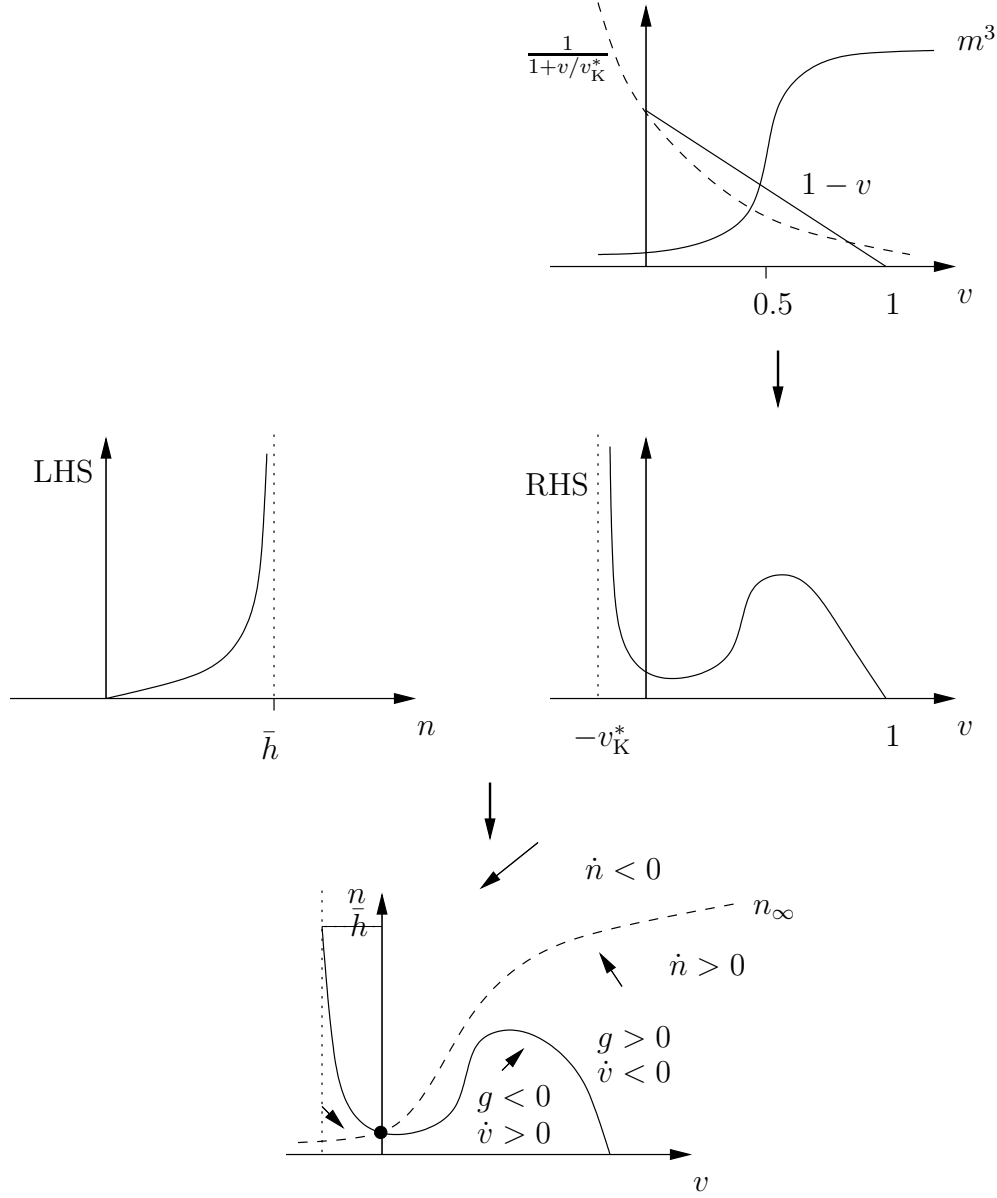

[Inclusion of  $\gamma_L$  near  $v = 0$  does not affect this, as then  $\frac{n^4}{h-n} \approx \frac{\gamma_L(v_L^*-v)}{\gamma_K(v+v_K^*)}$   
 Note that when  $v = 1$ ,  $g > 0$  for  $n > 0 \Rightarrow \dot{v} < 0$ .

**Phase-plane analysis** near equation at  $v = 0$ ,  $n = n_\infty(0)$ , linearise  $n = n_\infty(0) + N$  to get

$$\frac{d}{dt} \begin{pmatrix} N \\ v \end{pmatrix} = \begin{pmatrix} -1 & n'_\infty \\ -g_n & -g_v \end{pmatrix} \begin{pmatrix} N \\ v \end{pmatrix}.$$

Trace  $T = -1 - g_v$ . Determinant  $D = g_v + g_n n'_\infty$ . Near  $v = 0$ ,  $g \approx \gamma_K(v + v_K^*)n^4 + \gamma_L(v - v_L^*) \Rightarrow g_n > 0$ ,  $g_v > 0$  while  $n'_\infty > 0$ . Hence  $D > 0$ ,  $T < 0 \Rightarrow$  stable node or spiral.

[ASIDE:

$$\begin{pmatrix} x \\ y \end{pmatrix}' \approx \begin{pmatrix} a & b \\ c & d \end{pmatrix} \begin{pmatrix} x \\ y \end{pmatrix}.$$

Eigenvalues

$$\det \begin{pmatrix} a - \lambda & b \\ c & d - \lambda \end{pmatrix} = \lambda^2 - (a + b)\lambda + ad - bc = 0,$$

i.e.

$$\lambda^2 - T\lambda + D = 0, \quad \Rightarrow \lambda = \frac{T}{2} \pm \frac{\sqrt{T^2 - 4D}}{2}.$$

But, a sufficiently large perturbation of  $v$  excites an *action potential*.

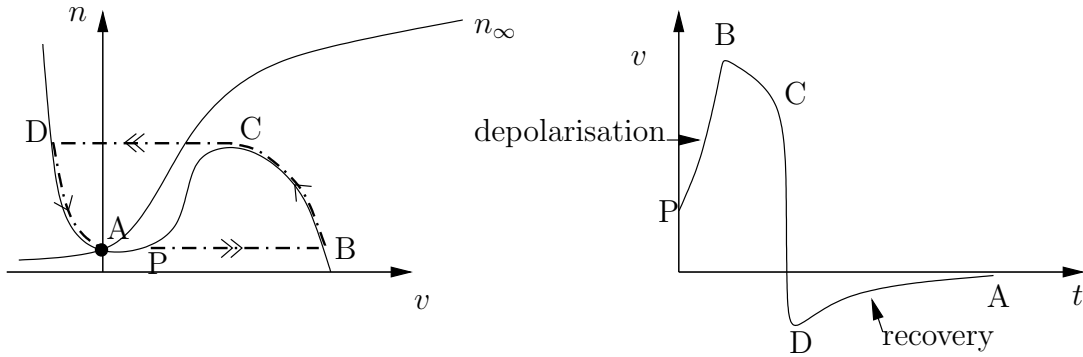

The FitzHugh-Nagumo model is simply (with  $w = n - n_\infty(0)$ )

$$\begin{aligned} \varepsilon \dot{v} &= I^* + f(v) - w, \\ \dot{w} &= \gamma v - w \end{aligned}$$

i.e.  $g = w - f(v)$ , and e.g.  $f = v(v - a)(1 - v)$  with  $a \in (0, 1)$ .

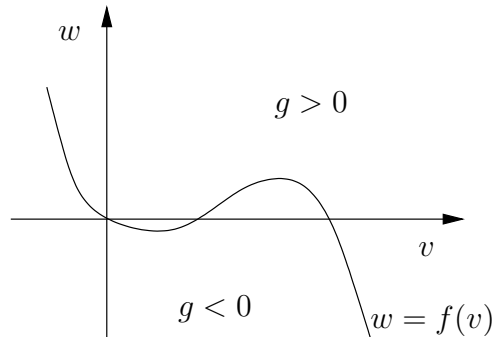

**Limit cycles** If we apply a current  $I^*$  then there may be a range  $I_- < I^* < I_+$  [depending on the shape of the curve  $g = 0$ ] where the phase plane is



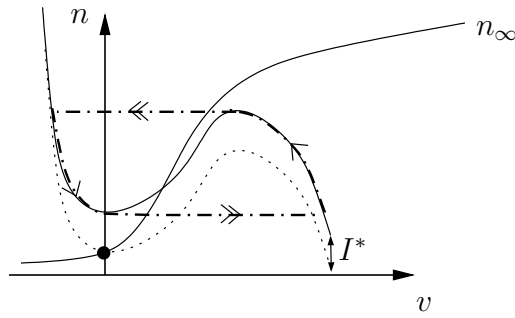

Now  $g_v < 0$ ,  $g_n > 0$ ,  $n'_\infty > -g_v/g_n$  so that  $D > 0$ .  $T = -1 - g_v$  can be positive  $\Rightarrow$  unstable  $\Rightarrow$  relaxation oscillation. Periodic neuron firing.

## 2.4 Notes and references

### Exercises

- 2.1 Carrier-mediated transport of a substrate  $S$  by a carrier protein  $C$  is modelled as the (rapid) reaction system

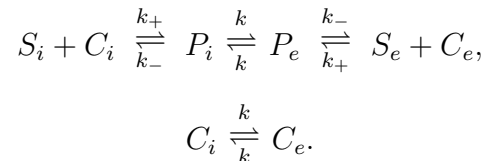

Explain the meaning of these reactions. If a substrate flux  $J$  is supplied to the exterior membrane surface and removed from the interior surface, use steady state kinetics to show that

$$J = \frac{K^*(S_e - S_i)}{(K_m + S_i)(K_m + S_e) - K_d^2},$$

where  $K^*$ ,  $K_d$  and  $K_m$  should be defined.

- 2.2 (a) A membrane ion channel has two gates activated by a protein. If  $n$  denotes the fraction of open gates in a cell membrane, explain why the fraction of open channels is  $n^2$ .
- (b) An ion channel has three gates, two controlled by an activating protein  $A$ , and the other controlled by an inactivating protein  $B$ . If the density of open  $B$  gates is  $h$ , explain why the density of open channels is  $m^2h$ . How does this result generalise to  $r$  proteins controlling  $s$  gates?
- 2.3 Write down the Hodgkin-Huxley model of trans-membrane conduction, and explain its derivation. Non-dimensionalise the model, and show that with certain parametric assumptions (which you should explain) it reduces to

$$\begin{aligned} \dot{n} &= n_\infty(v) - n, \\ \varepsilon \dot{v} &= I^* - g(v, n), \end{aligned}$$

where  $v$  is membrane potential and  $n$  is a gating variable, and show that  $g$  can be written as

$$g = \gamma_K(v + v_K^*)n^4 + \gamma_L(v - v_L^*) - (1 - v)(\bar{h} - n)m^3(v).$$

Give typical values of  $\gamma_K$ ,  $\gamma_L$ ,  $\bar{h}$ ,  $v_L^*$ ,  $v_K^*$ ,  $\varepsilon$ . Giving reasons, derive the graphical form of the  $v$  nullcline,  $g = 0$ . Hence deduce that (if  $n'_\infty$  is large enough) the membrane is *excitable*, defining also what this means.

# Chapter 3

## Wave propagation in neurons

### 3.1 Excitable media

The axon acts like a cable.

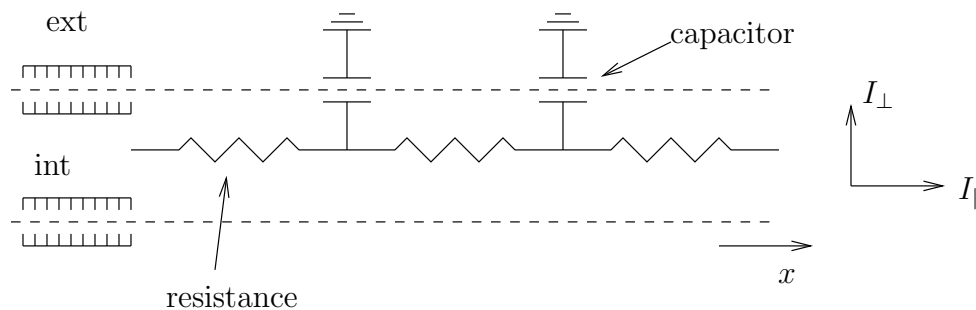

Let  $I_{\perp}$  be the transmembrane current (per unit length), and  $I_{\parallel}$  be the axial current in the  $x$  direction. If  $R$  is the axial resistance per unit length and  $C$  is the capacitance per unit length then in a segment  $(x, x + \delta x)$   $CV \delta x$  is the charge.

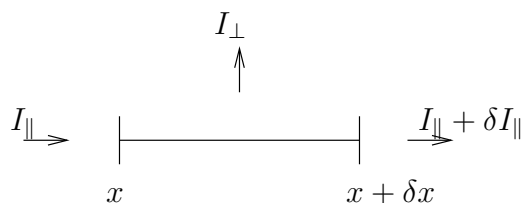

So

$$C \frac{\partial V}{\partial t} \delta x = -I_{\perp} \delta x - \frac{\partial I_{\parallel}}{\partial x} \delta x,$$

$$\Rightarrow C \frac{\partial V}{\partial t} = -I_{\perp} - \frac{\partial I_{\parallel}}{\partial x}.$$

Also

$$-\frac{\partial V}{\partial x} \delta x = I_{\parallel} R \delta x,$$

$$\Rightarrow -\frac{\partial V}{\partial x} = I_{\parallel} R.$$

$I_{\perp}$  = ionic current [- applied inward current]. Thus

$$C \frac{\partial V}{\partial t} = -I_{\perp} + \frac{1}{R} \frac{\partial^2 V}{\partial x^2}.$$

Hence cable gives diffusion for  $V$ , diffusion coefficient  $1/RC$ .

**Units** Note that previously  $I_i$  was the current density (current/unit area of membrane), while  $C_m$  was the capacitance per unit area.

To determine  $I_{\perp}$  and  $C$  (current/capacitance per unit length of axon) we have  $I_{\perp} = pI_i$ ,  $C = pC_m$  where  $p$  = perimeter of axon. Thus

$$C_m \frac{\partial V}{\partial t} = I - I_i + \frac{1}{pR} \frac{\partial^2 V}{\partial x^2},$$

$C_m$ ,  $I_i$  as before, and  $R$  = resistance per unit length, and  $R = R_c/A_i$  where  $R_c$  = cytoplasmic resistance,  $A_i$  = cross-sectional area. [Or, conductivity per unit length is  $1/R = A_i/R_c$ , with  $1/R_c$  the conductivity per unit volume.]

**Nondimensionalise** as before:  $V - V_{eq} \sim V_{Na}$ ,  $t \sim \tau_n$ ;  $m \approx m(V)$ , and  $x \sim l$ . Use  $I_i = g_{Na} V_{Na} g(n, v)$  and we find

$$\begin{aligned} \varepsilon \frac{\partial V}{\partial t} &= I^* - g(n, v) + \varepsilon^2 \frac{\partial^2 V}{\partial x^2}, \\ \frac{\partial n}{\partial t} &= n_{\infty}(v) - n. \end{aligned}$$

[need  $\varepsilon^2$  to resolve the rapid jumps in  $n, v$  space] in the reduced model if we define

$$l = \left( \frac{r_H g_{Na}}{R_c} \right)^{1/2} \frac{\tau_n}{C_m} \quad \text{where } r_H = \frac{A_i}{p} = \text{hydraulic radius} = \frac{d}{4} \text{ for circle, } d = \text{diameter}$$

Use values for squid giant axon

$$\begin{aligned} d = 5 \times 10^{-2} \text{ cm} &\Rightarrow r_H = 1.25 \times 10^{-2} \text{ cm}; \quad g_{Na} = 120 \text{ mS cm}^{-2}; \quad R_c = 30 \Omega \text{ cm}; \\ \tau_n = 5 \text{ ms}; \quad C_m = 1 \mu\text{F cm}^{-2} &\Rightarrow l \sim 35 \text{ cm (will be less in practice)}. \end{aligned}$$

## 3.2 Wave propagation in the FitzHugh-Nagumo model

$$\begin{aligned} \varepsilon v_t &= f(v) - w + \varepsilon^2 v_{xx}, \\ w_t &= \gamma v - w. \end{aligned}$$

Look for a solution  $v = v(\xi)$ ,  $w = w(\xi)$ ,  $\xi = ct - x$  ( $c > 0$ ).

$$\begin{aligned} \varepsilon c v' &= f(v) - w + \varepsilon^2 v'', \\ c w' &= \gamma v - w, \end{aligned}$$

with  $v = w = 0$  at  $\pm\infty$  (solitary wave).

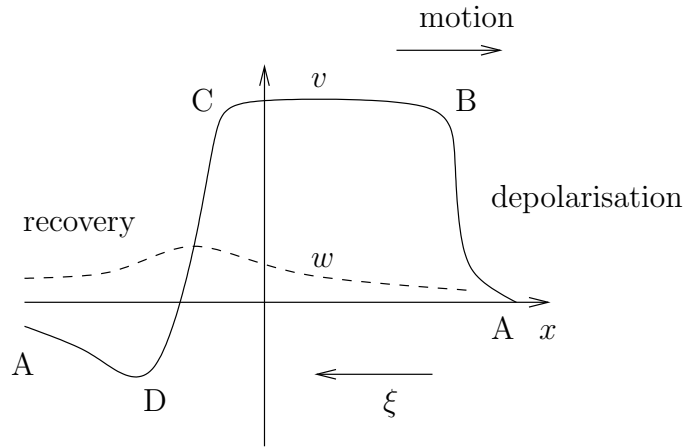

**I. Wavefront AB**  $\xi = \varepsilon X, w = O(\varepsilon) \Rightarrow cv' \approx f(v) + v'' \Rightarrow$  phase plane

$$\begin{aligned} v' &= u, \\ u' &= cu - f(v). \end{aligned}$$

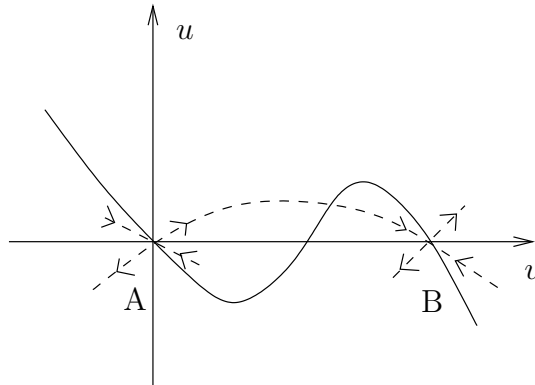

Choose  $c$  so that  $v$  goes from 0 to  $v_B (= 1$  for  $f = v(a - v)(v - 1)$ ).

**II. Wavefront BC**  $\xi = O(1), w \approx f(v), cw' \approx \gamma v - w$ . Integrate  $w$  from 0 to  $w_C$  (to be chosen). Phase plane

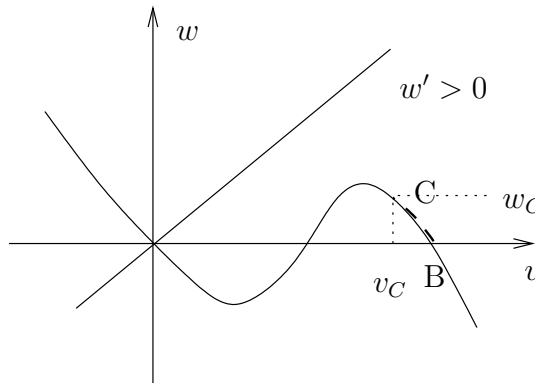

III. Trailing  $v$  wave CD  $\xi = \varepsilon X$ ,  $w \approx w_C$ , phase plane

$$\begin{aligned} v' &= u, \\ u' &= cu + w_C - f(v). \end{aligned}$$

Given  $c$ , choose  $w_C$  to that  $v$  goes from  $v_C$  to  $v_D$ .

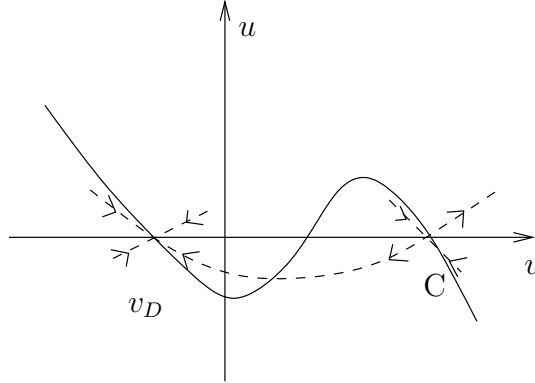

IV. Trailing  $w$  wave DA  $\xi = O(1)$ ,  $w \approx f(v)$ ,  $cw' \approx \gamma v - w$ . Integrate  $w$  back to zero.

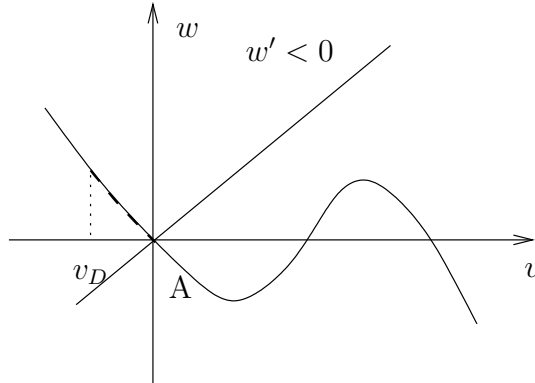

### 3.3 Notes and references

#### Exercises

3.1 The FitzHugh-Nagumo model for an action potential is

$$\begin{aligned} \varepsilon \dot{v} &= I^* + f(v) - w, \\ \dot{w} &= \gamma v - w, \end{aligned} \tag{3.1}$$

and you may assume  $\varepsilon \ll 1$ . Explain the meaning of the terms in these equations, and describe where the equations come from.

Suppose  $f = v(a-v)(v-1)$ , where  $0 < a < 1$ . Show that the system is excitable if  $I^* = 0$  and  $\gamma$  is large enough, and that it may spontaneously oscillate if  $I^* > 0$ . Give an explicit criterion for such oscillations to occur, in terms of  $I^*$ ,  $\gamma$  and  $a$ .

3.2 If the membrane potential of an axon is  $V$  and the transverse membrane current is  $I_\perp$ , derive the cable equation

$$C \frac{\partial V}{\partial t} = -I_\perp + \frac{1}{R} \frac{\partial^2 V}{\partial x^2},$$

explaining also the meaning of the terms. What is meant by the resting potential  $V_{\text{eq}}$ ?

Suppose

$$V - V_{\text{eq}} = v_{Na}v, \quad t \sim \tau_n, \quad x \sim l, \quad I_\perp = pg_{Na}v_{Na}g(n, v),$$

such that  $v$  and  $n$  satisfy the dimensionless equations

$$\begin{aligned} \varepsilon v_t &= -g(n, v) + \varepsilon^2 v_{xx}, \\ n_t &= n_\infty(v) - n. \end{aligned} \tag{3.2}$$

How must  $l$  be chosen to obtain this form? What is the definition of  $\varepsilon$ ?

3.3 The Fitzhugh-Nagumo model for signal propagation in nerve cells is

$$\begin{aligned} \varepsilon v_t &= f(v) - w + \varepsilon^2 v_{xx}, \\ w_t &= \gamma v - w. \end{aligned} \tag{3.3}$$

Explain the origins of this model, and explain in detail why travelling waves exist if  $\varepsilon \ll 1$ .

# Chapter 4

## Calcium dynamics

### 4.1 Calcium-induced calcium release

**Calcium dynamics** [K/S 5.1, 5.2; Goldbeter Ch. 9] Intracellular calcium  $\text{Ca}^{2+}$  is important in a number of physiological systems, e.g. muscle contraction, cardiac signalling, etc. Majority of  $\text{Ca}^{2+}$  is stored in bones, whence it is released by hormonal stimulation to maintain an extracellular  $\text{Ca}^{2+}$  concentration of around  $10^{-3}\text{M}$  ( $1\text{M} = 1 \text{ molar} = 1 \text{ mole/litre}$ ). But intracellular  $\text{Ca}^{2+}$  concentrations are low, around  $10^{-7}\text{M}$ . Therefore control mechanisms must exist to (i) keep intracellular levels low, (ii) enable rapid release when required. In certain circumstances (e.g. under hormonal stimulation) *oscillations* in  $\text{Ca}^{2+}$  concentrations occur.

Calcium is also stored in internal cell compartments, the endoplasmic reticulum (ER) (in all cells), and the *sarcoplasmic reticulum* (SR) (e.g. in muscle cells, heart cells) [or *calcium-sequestering compartment* in non-muscle cells].

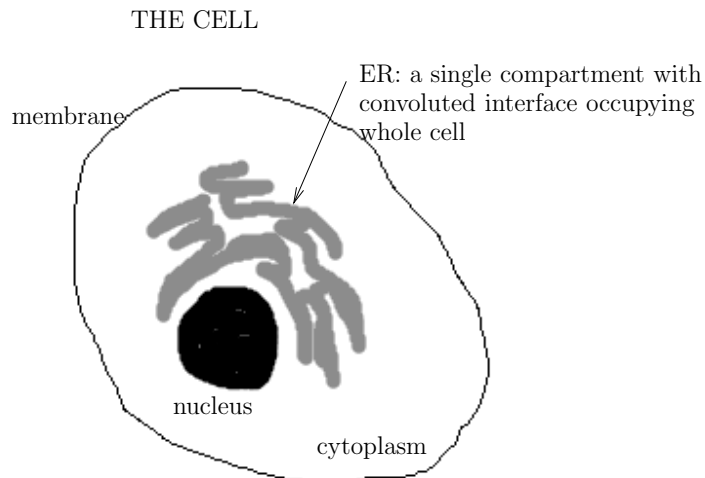



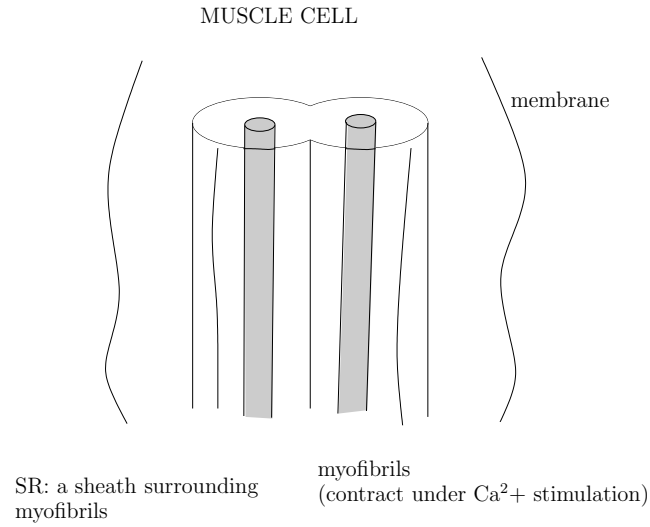

**Oscillations** [e.g. Goldbeter p353 ]

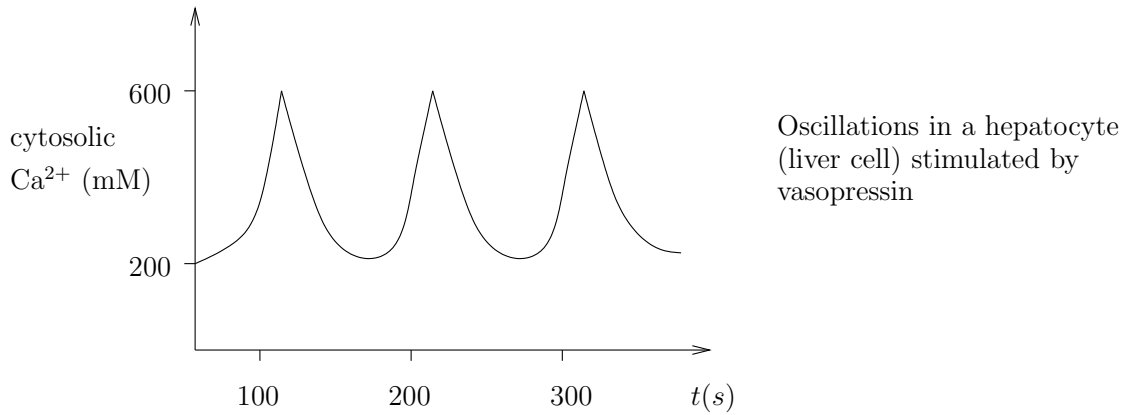

Oscillations occur when cells are stimulated by neurotransmitters or hormones. Note

- Oscillations occur in a limited range of stimulation intensity.
- Oscillations are spiky, frequency increases with stimulation intensity.

**The two pool model**

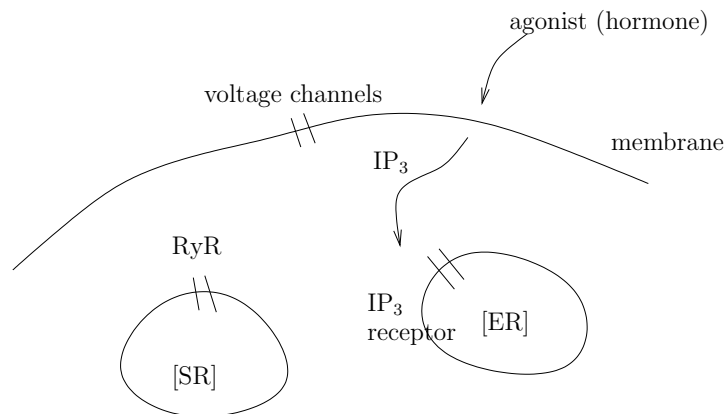

Calcium transfer occurs through IP<sub>3</sub> (inositol (1,4,5)-triphosphate) receptors and Ryanodine receptors. A hormone causes release of IP<sub>3</sub>, diffusing to IP<sub>3</sub> receptors, opening gate allowing release of Ca<sup>2+</sup>. Ryanodine receptors are associated with Ca<sup>2+</sup> induced Ca<sup>2+</sup> release (CICR).

**Mechanism:** Hormone → IP<sub>3</sub> → Ca<sup>2+</sup> release from IP<sub>3</sub> sensitive store → Ca<sup>2+</sup> release from Ca<sup>2+</sup> sensitive store; excess Ca<sup>2+</sup> is pumped out of cell.

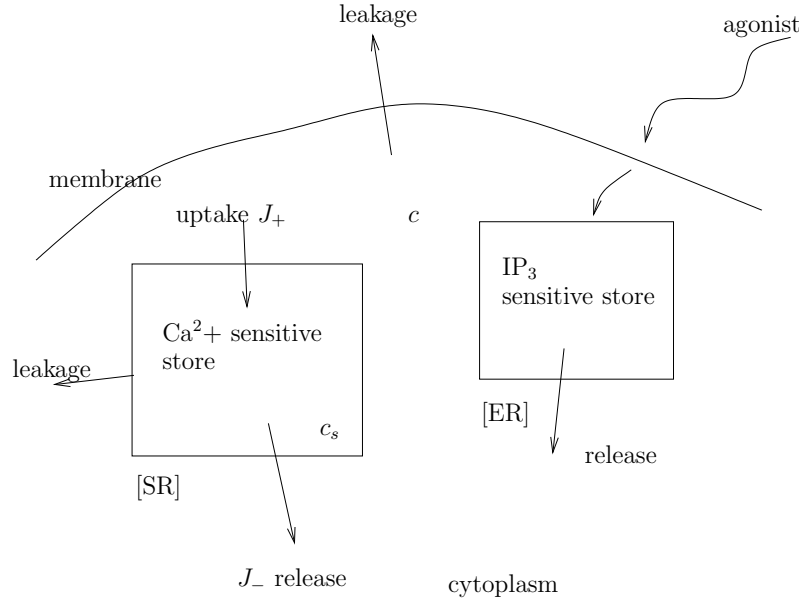

## 4.2 Intracellular oscillations

Let  $c$  = concentration of Ca<sup>2+</sup> in cytoplasm.  $c_s$  = concentration of Ca<sup>2+</sup> in Ca<sup>2+</sup> sensitive store. [Assume Ca<sup>2+</sup> constant in IP<sub>3</sub> sensitive store, so stimulus produces constant release rate of Ca<sup>2+</sup>.] Voltage gate leakage from store and cytoplasm. ⇒

$$\frac{dc}{dt} = \underbrace{r}_{\text{release from IP}_3 \text{ store}} - \underbrace{kc}_{\text{leakage to outside}} - \left[ \underbrace{J_+}_{\text{uptake by RyRs}} - \underbrace{J_-}_{\text{CICR}} - \underbrace{k_s c_s}_{\text{leakage from Ca}^{2+} \text{ store}} \right],$$

$$\frac{dc_s}{dt} = J_+ - J_- - k_s c_s,$$

and we choose Hill forms for  $J_{\pm}$ :

$$J_+ = \frac{V_1 c^n}{K_1^n + c^n},$$

$$J_- = \left( \frac{V_2 c_s^m}{K_2^m + c_s^m} \right) \underbrace{\left( \frac{c^p}{K_3^p + c^p} \right)}_{\text{the CICR part}}.$$

## Nondimensionalisation

$$c = K_1 u, \quad t \sim \frac{1}{k}, \quad c_s = K_2 v, \quad \Rightarrow$$

$$\dot{u} = \mu - u - \frac{\gamma}{\varepsilon} f(u, v),$$

$$\dot{v} = \frac{1}{\varepsilon} f(u, v)$$

$$\mu = \frac{r}{kK_1}, \quad \gamma = \frac{K_2}{K_1}, \quad \varepsilon = \frac{kK_2}{V_2};$$

$$f = \beta \left( \frac{u^n}{1+u^n} \right) - \left( \frac{v^m}{1+v^m} \right) \left( \frac{u^p}{\alpha^p + u^p} \right) - \delta v,$$

$$\alpha = \frac{K_3}{K_1}, \quad \beta = \frac{V_1}{V_2}, \quad \delta = \frac{k_s K_2}{V_2}.$$

Use values

$$k = 10 \text{ s}^{-1}, \quad K_1 = 1 \mu\text{M}, \quad K_2 = 2 \mu\text{M}, \quad K_3 = 0.9 \mu\text{M},$$

$$V_1 = 65 \mu\text{Ms}^{-1}, \quad V_2 = 500 \mu\text{Ms}^{-1}, \quad k_s = 1 \text{ s}^{-1}, \quad m = 2, \quad n = 2, \quad p = 4 \quad \Rightarrow$$

$$\alpha \sim 0.9, \quad \beta \sim 0.13, \quad \gamma \sim 2, \quad \delta \sim 0.004, \quad \varepsilon \sim 0.04.$$

Note  $\mu = 1$  if  $r = 10 \mu\text{Ms}^{-1}$ . (Use  $\mu$  as control parameter).

Define  $w = u + \gamma v$ . Then

$$\dot{w} = \mu - (w - \gamma v),$$

$$\varepsilon \dot{v} = F(w, v),$$

$$F(w, v) = f(w - \gamma v, v).$$

**Phase plane analysis** Since  $\varepsilon \ll 1$ ,  $v$  rapidly goes to equilibrium  $f = 0$  on time scale  $t \sim \varepsilon$ .

$$f = \beta \left( \frac{u^n}{1+u^n} \right) - \left( \frac{v^m}{1+v^m} \right) \left( \frac{u^p}{\alpha^p + u^p} \right) - \delta v,$$

$\delta \ll 1$ , so  $f = 0$  ( $v$  nullcline) is

$$L(v) \equiv \frac{v^m}{1+v^m} \approx \beta \left( \frac{u^n}{1+u^n} \right) / \left( \frac{u^p}{\alpha^p + u^p} \right) \equiv \frac{J(u)}{K(u)}$$

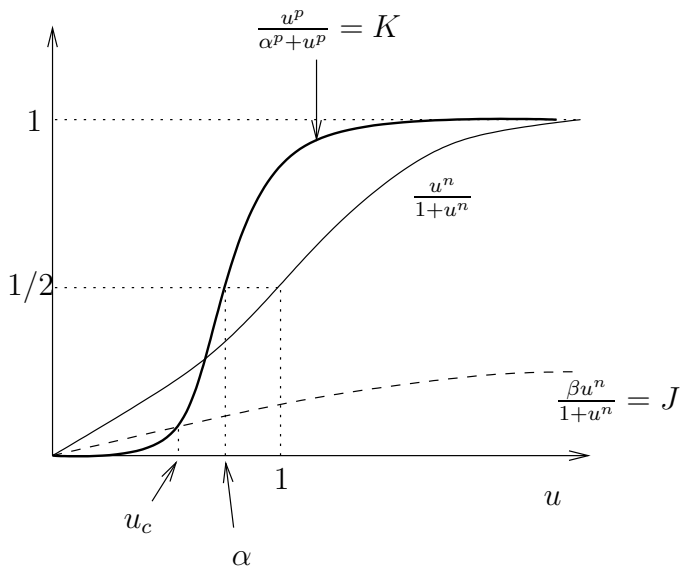

$n = 2$   
 $p = 4$

Note:  $\frac{u^n}{1+u^n} \sim u^n$  as  $u \downarrow 0$   
 $\frac{u^n}{1+u^n} \sim 1 - \frac{1}{u^n}$  as  $u \uparrow \infty$

$\Rightarrow R \equiv \beta \left( \frac{u^n}{1+u^n} \right) / \left( \frac{u^p}{\alpha^p + u^p} \right)$

$R = 1$  at  $u = u_c$

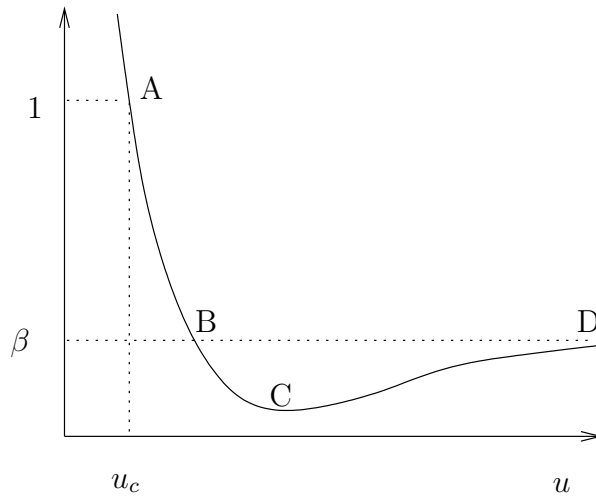

$\approx L$

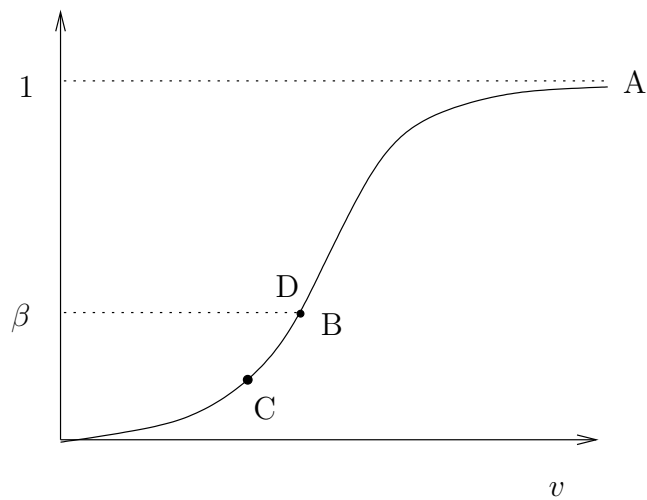

$m = 2$

whence

But, when  $v \rightarrow \infty$ ,  
 $\delta v$  comes back in.

$$\frac{v^m}{1+v^m} \approx 1$$

$$\Rightarrow v \approx \frac{1}{\delta} \left[ \beta \left( \frac{u^n}{1+u^n} \right) - \left( \frac{u^p}{\alpha^p+u^p} \right) \right]$$

(= 0 at  $u = u_c$ )

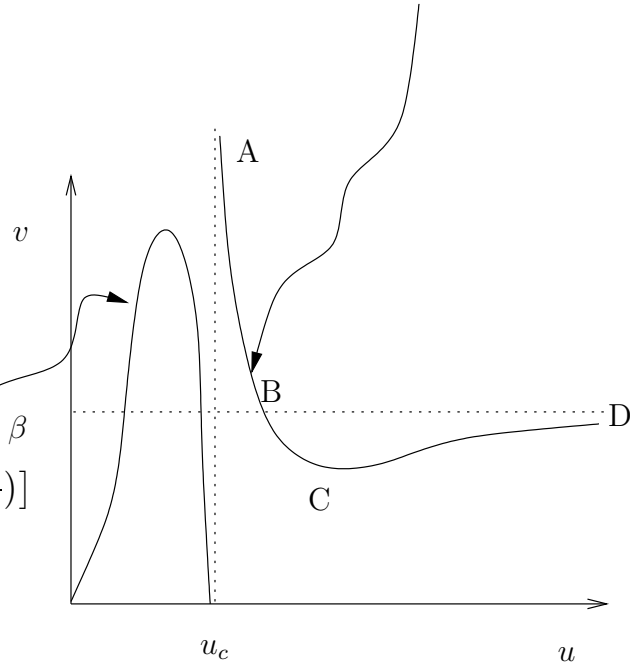

There will be an overlap region where  $v \gg 1$  and  $u \approx u_c$ . Denote  $J = \frac{\beta u^n}{1+u^n}$ ,  
 $K = \frac{u^p}{\alpha^p+u^p}$ . Note  $J(u_c) = K(u_c)$ . Then

$$J(u_c) + J'(u_c)(u - u_c) + \dots - \left( 1 - \frac{1}{v^m} + \dots \right) (K(u_c) + K'(u_c)(u - u_c) + \dots) - \delta v = 0$$

$$\Rightarrow J(u_c) + J'(u_c)(u - u_c) + \dots - K(u_c) - K'(u_c)(u - u_c) + \dots + \frac{K(u_c)}{v^m} + \dots - \delta v = 0,$$

and note that  $K'(u_c) > J'(u_c)$ ,

$$\Rightarrow u - u_c \approx \frac{1}{(K'(u_c) - J'(u_c))} \left( \frac{K(u_c)}{v^m} - \delta v \right).$$

Overlap region where  $v \sim \frac{1}{\delta^{m+1}}$ ,  $u - u_c \sim \delta^{\frac{m}{m+1}}$

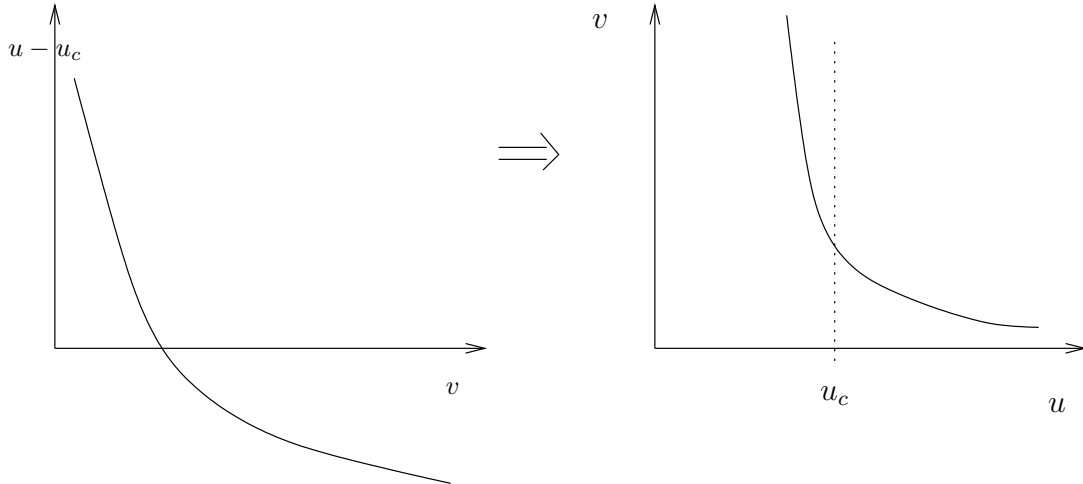

Thus, overall

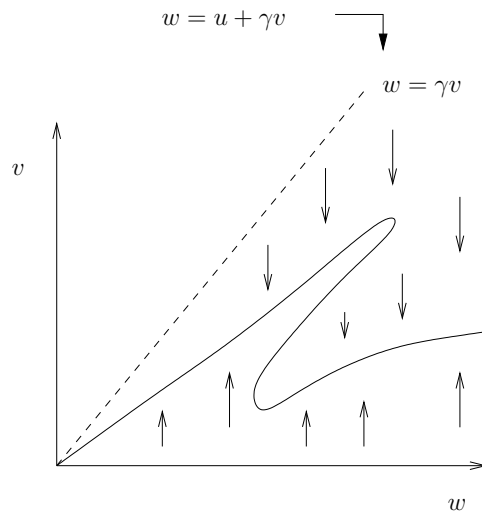
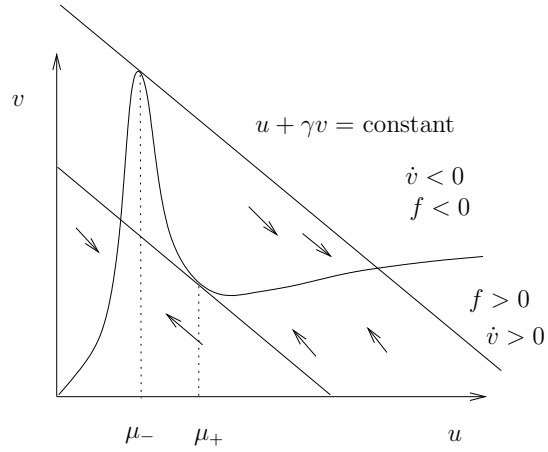
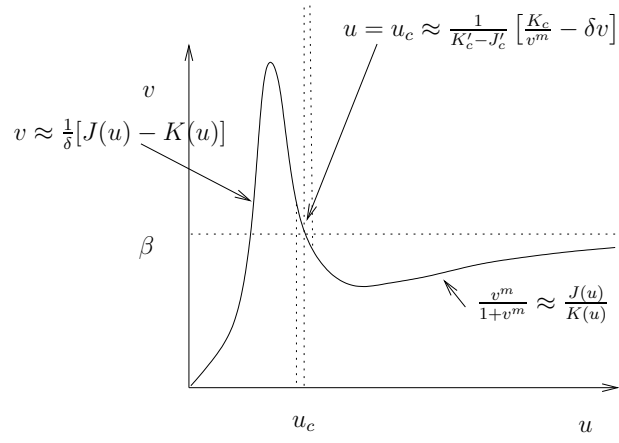

$$\begin{aligned} \dot{u} + \gamma \dot{v} &= \mu - u, \\ \varepsilon \dot{v} &= f(u, v); \end{aligned}$$

$v$  rapidly goes to  $f = 0$  ( $v$  nullcline), say  $v = g(u)$ . Then  $u + \gamma v = u + \gamma g(u)$  evolves slowly.

There are three possible values of  $v$  for given  $u + \gamma v$  in a certain range, bounded by values  $u = \mu_-$  and  $u = \mu_+$ . They correspond to values of  $u$  where

$$\frac{dw}{dv} = 0, \quad \Rightarrow \quad \frac{dw}{du} = 0 \text{ i.e. } \frac{dv}{du} = -\frac{1}{\gamma}.$$

Specifically, for  $\mu_-$  remember that

$$v \approx \frac{1}{\delta} \left[ \beta \left( \frac{u^n}{1 + u^n} \right) - \left( \frac{u^p}{\alpha^p + u^p} \right) \right] = \frac{1}{\delta} (J(u) - K(u)).$$

Hence  $\mu_-$  satisfies

$$J'(\mu_-) - K'(\mu_-) \approx -\frac{\delta}{\gamma} \quad (\approx 0).$$

For  $\mu_+$ , remember that

$$L(v) \equiv \frac{v^m}{1 + v^m} \approx \beta \left( \frac{u^n}{1 + u^n} \right) / \left( \frac{u^p}{\alpha^p + u^p} \right) \equiv \frac{J(u)}{K(u)}$$

so that  $\mu_+$  satisfies

$$L'(v_+) \frac{dv}{du} = -\frac{L'(v_+)}{\gamma} = \left( \frac{J}{K} \right)' (\mu_+), \quad \text{with } L(v_+) = \frac{J(\mu_+)}{K(\mu_+)}$$

i.e.

$$L' \left[ L^{-1} \left\{ \frac{J(\mu_+)}{K(\mu_+)} \right\} \right] + \gamma \left( \frac{J}{K} \right)' (\mu_+) = 0.$$

**For  $\mu < \mu_-$**  there is a stable steady state

$$u = \mu, \quad v \approx \frac{1}{\delta} [J(\mu) - K(\mu)];$$

(high internal storage  $v \sim 1/\delta$ ).

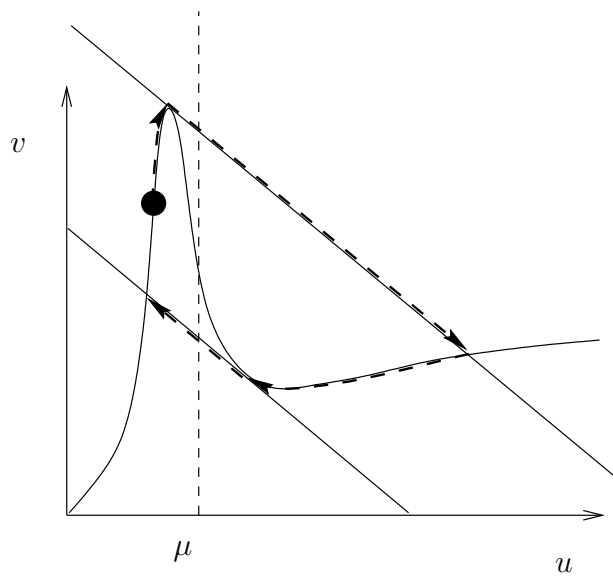
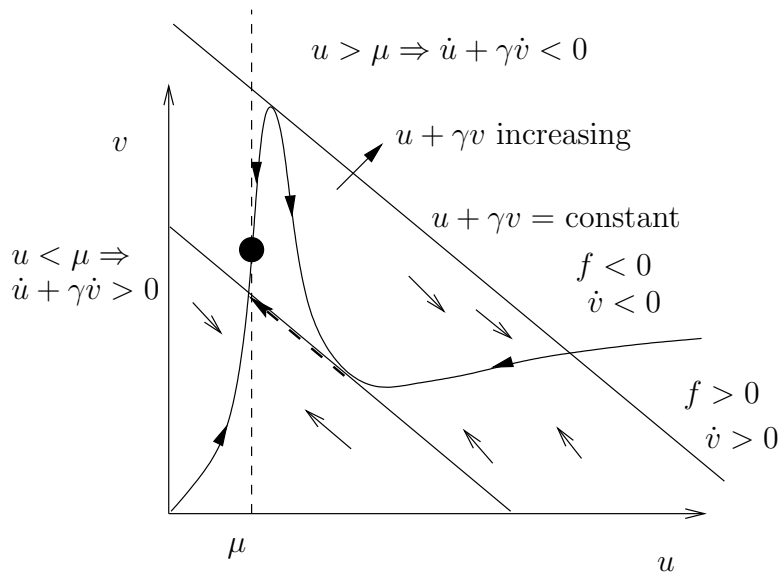

It is **excitable** for  $\mu < \mu_-$ . Putting  $\mu > \mu_-$  for a long enough time leads to a large excursion.

**For**  $\mu > \mu_+$  there is a stable steady state

$$u = \mu, \quad v \approx L^{-1} \left[ \frac{J(u)}{K(u)} \right];$$

(low internal storage).



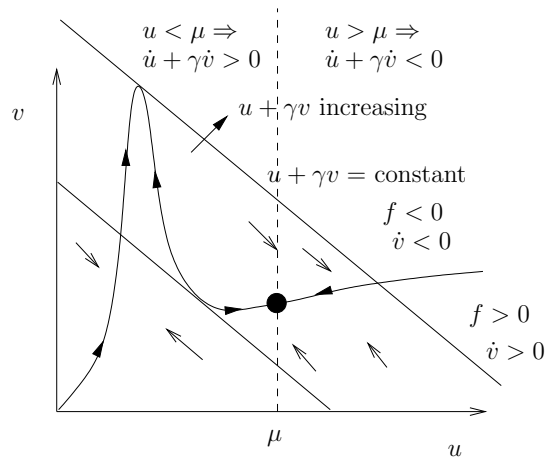

For  $\mu_- < \mu < \mu_+$  periodic oscillations occur in  $u$  (and  $v$ ). Equilibrium is unstable.

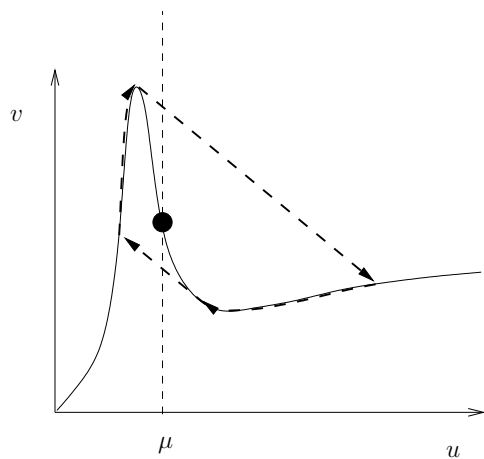
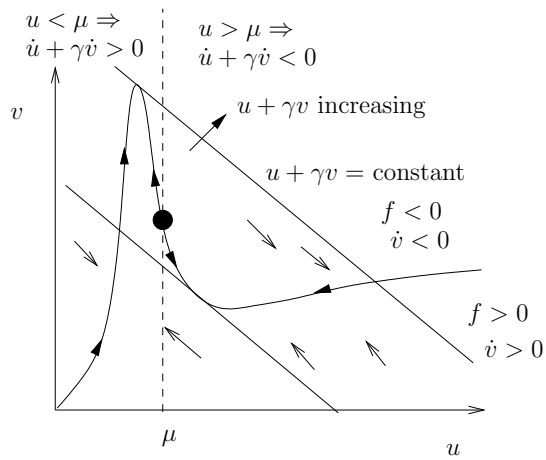

## Character of oscillations

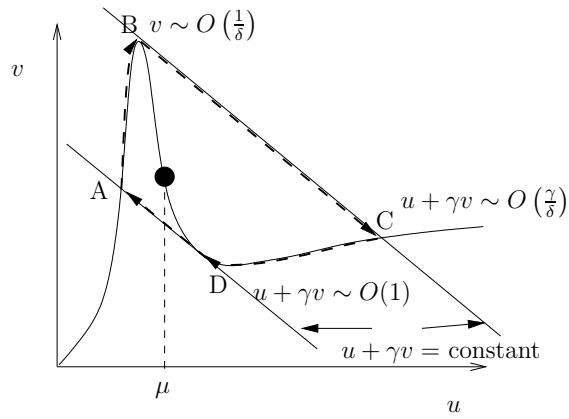
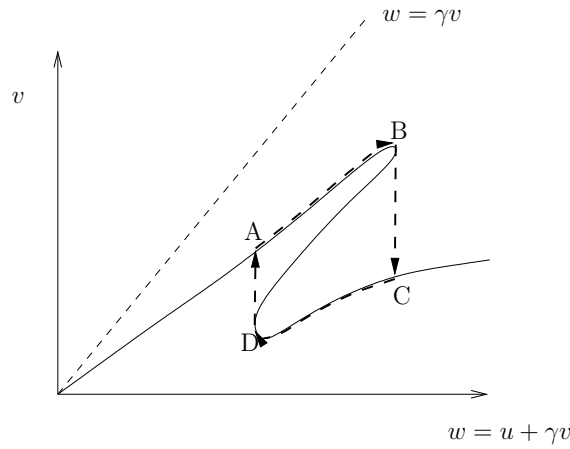

figs/ch4/

**DA:**  $t \sim O(\varepsilon)$ ,  $u$  jumps down an  $O(1)$  amount ( $v$  jumps up an  $O(1)$  amount).

**AB:**

$$v \approx \frac{1}{\delta} (J(u) - K(u)) \quad \left[ \approx \beta u^n - \left(\frac{u}{\alpha}\right)^p \quad \text{for small } u \text{ if } \beta \text{ is smallish} \right]$$

$$\dot{u} = \mu - u - \gamma \dot{v} \quad \Rightarrow \quad (1 + \gamma v'(u)) \dot{u} \approx \mu - u \quad \Rightarrow \quad \dot{u} \approx \frac{\delta(\mu - u)}{\gamma(J'(u) - K'(u))}.$$

Slow rise over timescale  $t \sim O(1/\delta)$  if  $u$  is  $O(1)$ .

**BC:**  $t \sim O(\varepsilon)$ ,  $u$  jumps up to  $O(1/\delta)$  ( $v$  jumps down to  $O(1)$ ).

**CD:**  $u \gg 1$ ,  $v \sim \beta$ ,  $\dot{u} \approx -u \Rightarrow u \approx O(1/\delta)e^{-t}$ . Thus it takes time  $t \sim O(\log(1/\delta))$  for  $u$  to drop to  $O(1)$ .

Spiky oscillations with asymmetrical shape. Essentially:

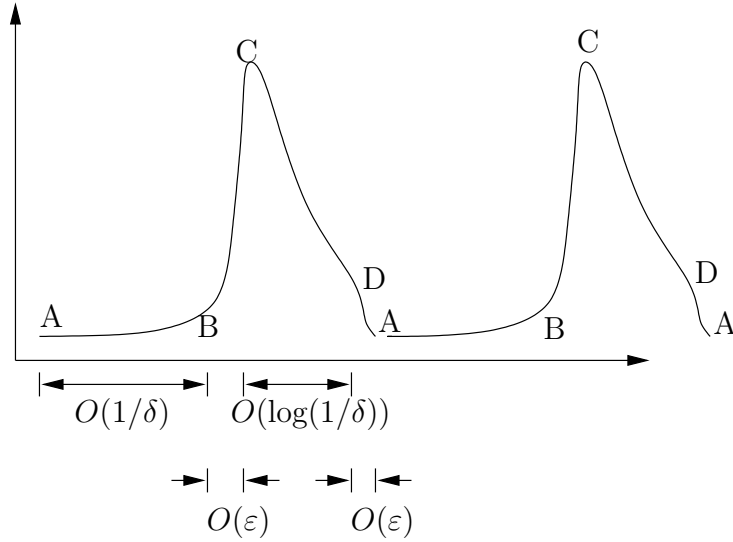

If  $u = u_A$  at A and  $u = u_B$  at B ( $u_A < u_B < \mu$ ) then the period of the oscillation is approximately

$$P = \int_A^B dt = \int_A^B \frac{du}{\dot{u}} = \frac{\gamma}{\delta} \int_{u_A}^{u_B} \frac{(J' - K') du}{\mu - u}$$

and depends on  $\mu$  with  $dP/d\mu < 0$ . Note that

$$\dot{u} = \mu - u - \gamma v, \quad \dot{v} \approx \frac{\dot{u}}{\delta} (J'(u) - K'(u)) \Rightarrow \dot{u} \approx \frac{(\mu - u)}{1 + \frac{\gamma}{\delta} (J'(u) - K'(u))} \approx \frac{\delta(\mu - u)}{\gamma(J'(u) - K'(u))}.$$

On the other hand, the **amplitude** is  $u_C$ , and is independent of  $\mu$ . Periodic solutions occur in the range  $\mu_- < \mu < \mu_+$ .

Dimensionally,

$$\begin{aligned} \text{period} &\sim \frac{1}{k} \frac{\gamma}{\delta} = \frac{1}{k} \frac{K_2}{K_1} \frac{V_2}{k_s K_2} = \frac{V_2}{k k_s K_1}, \\ \text{amplitude} &\sim K_1 \frac{\gamma}{\delta} = K_1 \frac{K_2}{K_1} \frac{V_2}{k_s K_2} = \frac{V_2}{k_s}. \end{aligned}$$

### 4.3 Wave propagation

**Calcium Waves** [K/S 12.1, 12.2 Goldbeter 9.6, Murray 11.6, 12.4, 12.5, Grindrod 3.3]  $\text{Ca}^{2+}$  oscillations can cause waves to propagate inside cells at speeds 10-100  $\mu\text{s}^{-1}$ . These are particularly evident in large cells (e.g. oocytes [developing eggs]) where periodic wave trains can be seen. Spiral waves have been seen in Xenopus Oocytes.

The simplest model to describe such waves is the 2 pool model where we also allow **diffusion** of cytosolic  $\text{Ca}^{2+}$ . Thus (nondimensionally), in 1D

$$\begin{aligned} u_t + \gamma v_t &= \mu - u + \nu u_{xx}, \\ \varepsilon v_t &= f(u, v), \end{aligned}$$

where  $\nu = \frac{D}{l^2k}$ ,  $l = \text{lengthscale}$ ,  $D = \text{diffusion coefficient}$ . We seek **travelling waves**  $u = u(\xi)$ ,  $v = v(\xi)$   $\xi = x + st$ . Note, we might expect  $s > 0$  if  $B \rightarrow C$  as  $\xi$  increases:

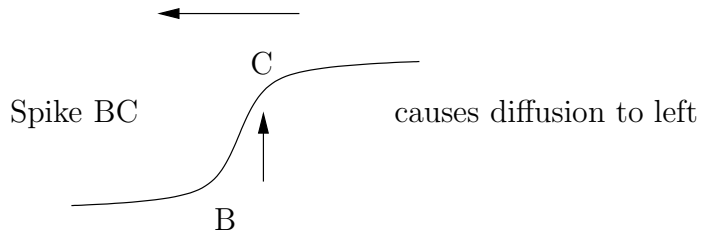

Thus

$$\begin{aligned} s(u' + \gamma v') &= \mu - u + \nu u'', \\ \varepsilon s v' &= f(u, v). \end{aligned}$$

We need diffusion on spikes of width  $\varepsilon$  so we must have  $\nu = \varepsilon$ , i.e.  $l = \left(\frac{D}{k\varepsilon}\right)^{1/2}$ .

$$D \sim 20 \mu\text{m}^2\text{s}^{-1}, \quad \varepsilon = 0.04, \quad k = 10 \text{s}^{-1} \quad \Rightarrow \quad l \sim 7 \mu\text{m} \quad (\text{reasonable}).$$

$\Rightarrow$  wavespeed  $\sim lk \sim 70 \mu\text{ms}^{-1}$  for  $s = O(1)$ .

### Spikes BC

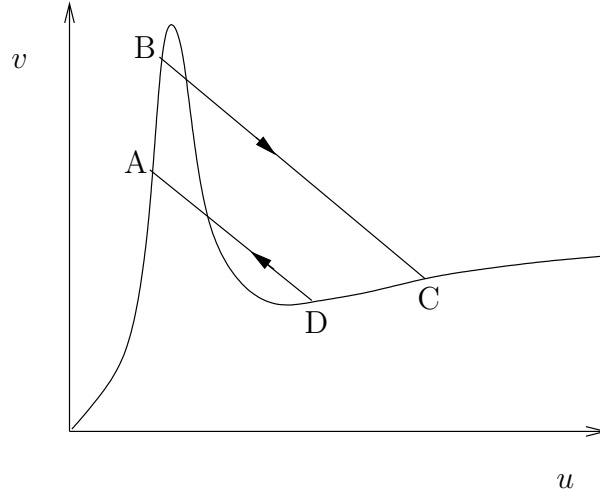

In  $BC$  and  $DA$ ,  $\xi = \varepsilon X \Rightarrow s(u' + \gamma v') \approx u''$  where  $u' = du/dX$  etc. Thus, after one integration,

$$\begin{aligned} u' &\approx (u - u_B + \gamma(v - v_B)), \\ s v' &\approx f(u, v), \end{aligned}$$

while on  $CD$ ,  $AB$ , with  $u' = du/d\xi$ ,  $f(u, v) \approx 0 \Rightarrow v \approx g(u)$  and

$$s(1 + \gamma g'(u))u' \approx \mu - u.$$

Suppose we are given  $u_B$ . Then  $v_B = g(u_B)$ . Write

$$\begin{aligned} U &= u - u_B, \\ V &= v - v_B, \\ f(u, v) &= F(U, V), \end{aligned}$$

Then, on  $BC$ , we have

$$\begin{aligned} U' &= s(U + \gamma V), \\ sV' &= F(U, V). \end{aligned}$$

**Phase plane**

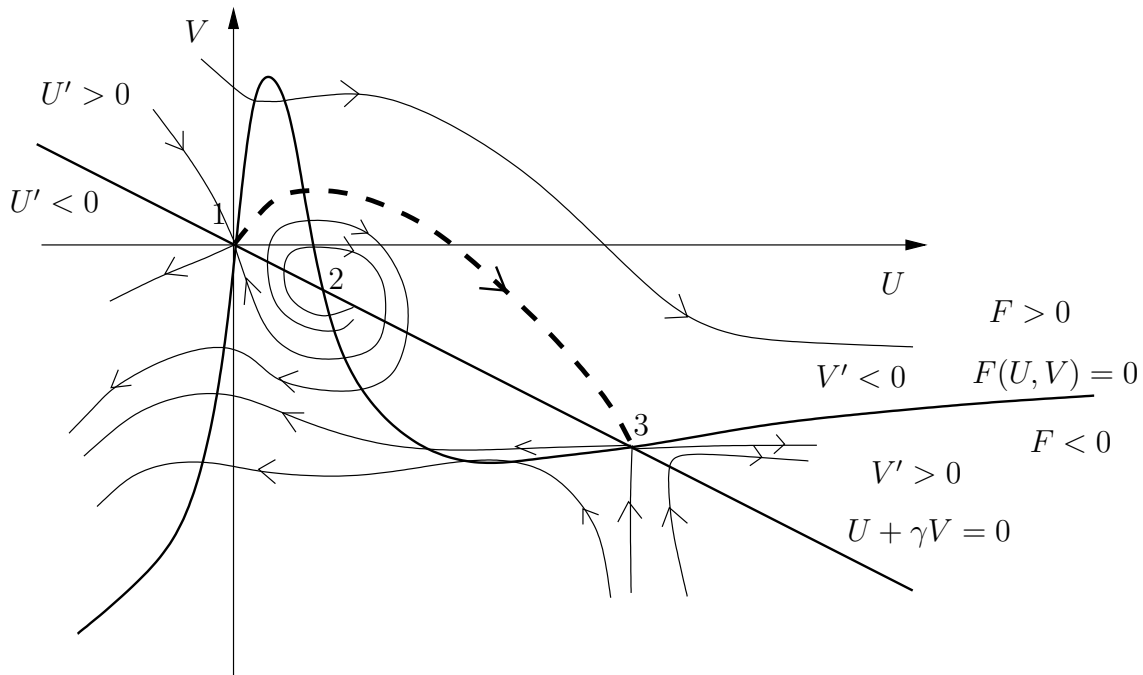

For a particular value of  $s$ , there is a connecting trajectory as shown. [As  $s \downarrow 0$ , trajectory  $\rightarrow$  stable equilibrium 2. As  $s \rightarrow \infty$ , trajectory  $\rightarrow$  horizontal.]

Derivation of phase plane:

Linearisation near equilibrium points:  $U = U_0 = \tilde{U}$  etc.

$$s \begin{pmatrix} \tilde{U} \\ \tilde{V} \end{pmatrix}' \approx \begin{pmatrix} s^2 & s^2 \gamma \\ F_U & F_V \end{pmatrix} \begin{pmatrix} \tilde{U} \\ \tilde{V} \end{pmatrix}.$$

$$\begin{aligned} \text{trace } T &= s^2 + F_V, \\ \det D &= s^2(F_V - \gamma F_U). \end{aligned}$$

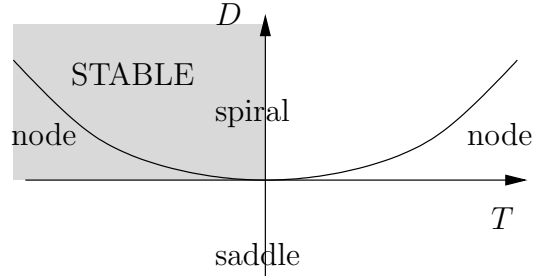

[ASIDE:

$$\begin{pmatrix} x \\ y \end{pmatrix}' \approx \begin{pmatrix} a & b \\ c & d \end{pmatrix} \begin{pmatrix} x \\ y \end{pmatrix}.$$

Eigenvalues

$$\det \begin{pmatrix} a - \lambda & b \\ c & d - \lambda \end{pmatrix} = \lambda^2 - (a + b)\lambda + ad - bc = 0,$$

i.e.

$$\lambda^2 - T\lambda + D = 0, \quad \Rightarrow \lambda = \frac{T}{2} \pm \frac{\sqrt{T^2 - 4D}}{2}.$$

At all equilibrium points  $F_V < 0$ .

At 1, 3  $F_U > 0 \Rightarrow D < 0 \Rightarrow$  saddle.

At 2  $F_U < 0$ .

At 2  $|F \text{ slope}| > |U + \gamma V \text{ slope}| \Rightarrow \frac{F_U}{F_V} > \frac{1}{\gamma} \Rightarrow D = s^2(F_V - \gamma F_U) > 0 \Rightarrow$  node or spiral.

As  $s \downarrow 0$ ,  $T < 0 \Rightarrow$  stable. As  $s \uparrow \infty$ ,  $T > 0 \Rightarrow$  unstable.

The same construction will work on the return jump  $DA$ , except given  $s$  (from  $BC$ ), we have to choose  $u_D$  (thus  $u_A$ ).

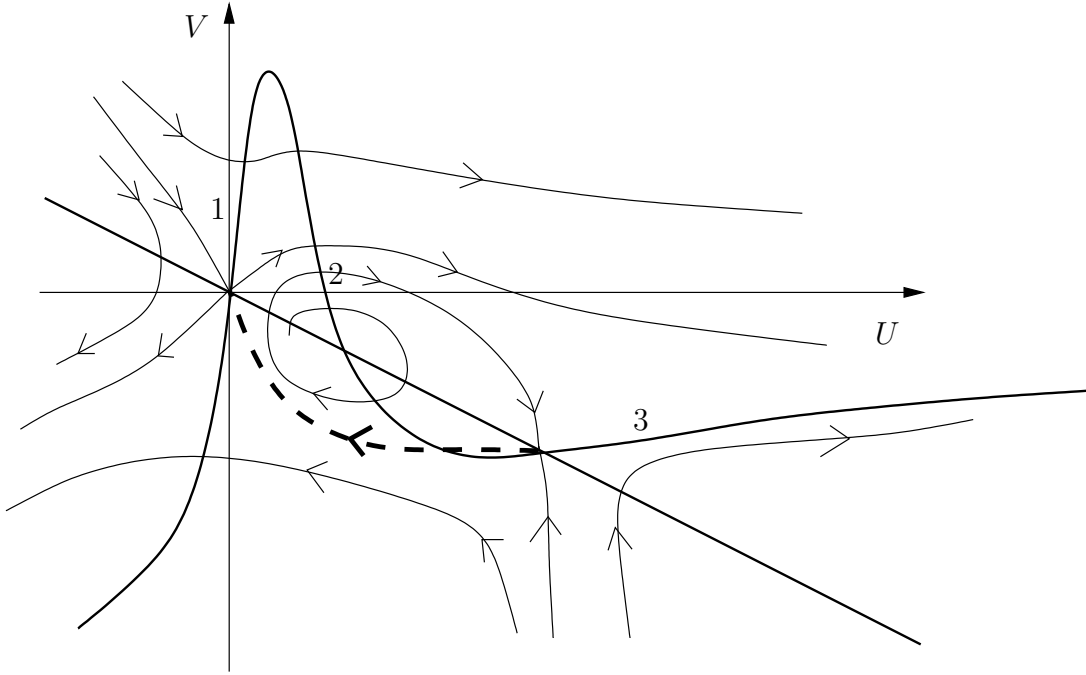

Thus, given  $u_B \Rightarrow u_C$ , select  $s$  for wavefront to form  $u_B$  to  $u_C$ . With this  $s$  select  $u_D \Rightarrow u_A$  to connect back. Solve  $s(1 + \gamma g'(u))u' \approx \mu - u$  on  $CD$  and  $AB$  to find wavelength. This requires  $u_B < \mu < u_A$  and so will work for all  $\mu \in (\mu_-, \mu_+)$ . Thus oscillatory kinetics  $\Rightarrow$  1 parameter ( $u_B$  or  $s$ ) family of periodic wavetrains.

If  $\mu < \mu_-$ , then we can choose  $u_A = \mu$  (stable steady state in kinetics) and there is a travelling solitary wave ( $u_A \rightarrow s \rightarrow u_B$ ). Excitable kinetics  $\Rightarrow$  solitary waves (c.f. FitzHugh-Nagumo).

**Spiral waves** These are rotating waves, and have been observed in  $\text{Ca}^{2+}$  waves in oocytes (eggs) e.g. *Xenopus* oocytes. Spiral waves can be described by periodic functions

$$u[\Omega t - m\theta - \psi(r)].$$

[Periodic oscillations in reaction kinetics  $\rightarrow$  periodic travelling waves.]

**Example** The heartbeat is generated by a pacemaker (oscillator) in the sinoatrial node which propagates a wave through the excitable *atria* and *ventricles*.

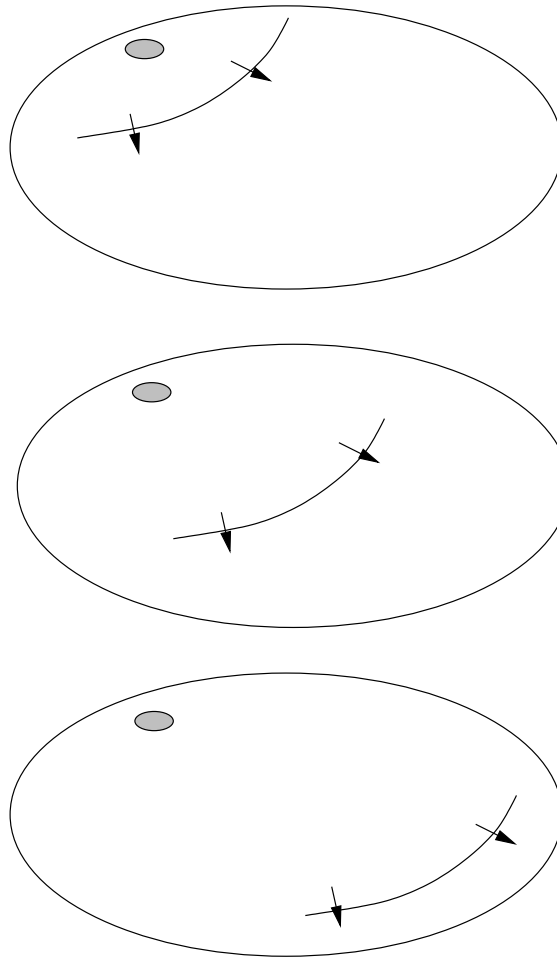

Blockage of conduction paths can lead to re-entrant spiral waves and *ventricular tachycardia*.



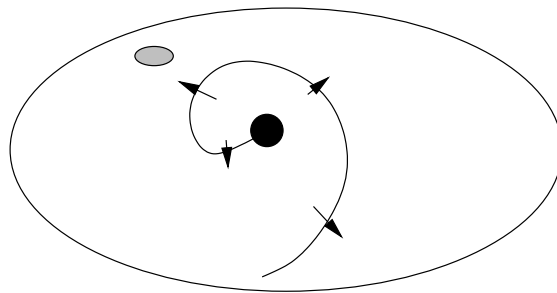
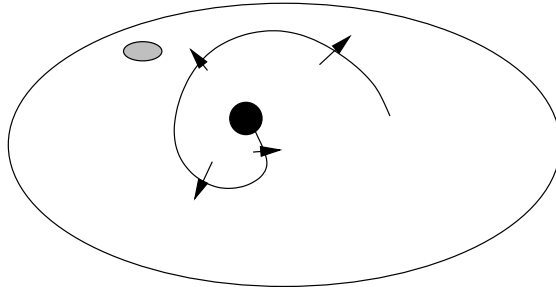
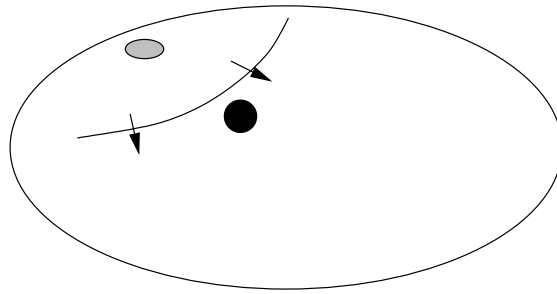

In the diseased heart, spiral waves become chaotic leading to ventricular fibrillation and death.

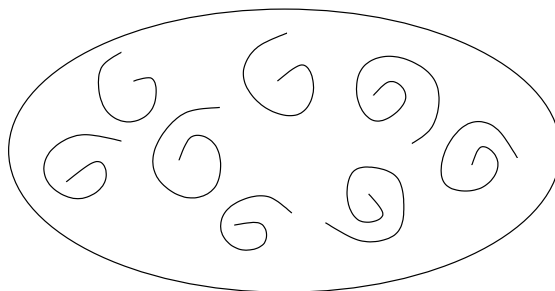

## 4.4 Notes and references

### Exercises

- 4.1 Describe the basic cell physiology of intracellular calcium exchange which is used in the two pool model:

$$\begin{aligned}\frac{dc}{dt} &= r - kc - [J_+ - J_- - k_s c_s], \\ \frac{dc_s}{dt} &= J_+ - J_- - k_s c_s, \\ J_+ &= \frac{V_1 c^n}{K_1^n + c^n}, \\ J_- &= \left( \frac{V_2 c_s^m}{K_2^m + c_s^m} \right) \left( \frac{c^p}{K_3^p + c^p} \right).\end{aligned}$$

Non-dimensionalise the model to obtain the equations

$$\begin{aligned}\dot{u} &= \mu - u - \gamma \dot{v}, \\ \varepsilon \dot{v} &= f(u, v), \\ f &= \beta \left( \frac{u^n}{1 + u^n} \right) - \left( \frac{v^m}{1 + v^m} \right) \left( \frac{u^p}{\alpha^p + u^p} \right) - \delta v,\end{aligned}$$

and define  $\alpha, \beta, \gamma, \delta, \varepsilon$ .

Given  $k = 10 \text{ s}^{-1}$ ,  $K_1 = 1 \text{ } \mu\text{M}$ ,  $K_2 = 2 \text{ } \mu\text{M}$ ,  $K_3 = 0.9 \text{ } \mu\text{M}$ ,  $V_1 = 65 \text{ } \mu\text{M s}^{-1}$ ,  $V_2 = 500 \text{ } \mu\text{M s}^{-1}$ ,  $k_s = 1 \text{ s}^{-1}$ ,  $m = 2$ ,  $n = 2$ ,  $p = 4$ , find approximate values of  $\alpha, \beta, \gamma, \delta, \varepsilon$ .

- 4.2 Using the model of 1 with  $\varepsilon \ll 1$ , explain why  $v \approx g(u)$ , and derive an approximate (graphical) representation for  $g(u)$ , assuming  $\delta \ll 1$ . Hence show that there is a range of values of  $\mu$  for which periodic solutions are obtained, and give approximate characterisations of the form of the oscillations of the cytosolic  $\text{Ca}^{2+}$  concentration  $u$ ; in particular, explain the spikiness of the oscillation, and show that the amplitude is approximately independent of  $\mu$ , but that the period decreases as  $\mu$  increases.

What happens if  $n > p$ ?

- 4.3 Show that the model of 1 has a unique steady state (with  $u, v > 0$ ). Show that it is oscillatorily unstable if

$$\varepsilon - f_v < -\gamma f_u$$

at the fixed point, and deduce that if  $g(u)$  is defined by  $f[u, g(u)] = 0$ , and  $\varepsilon \ll 1$ , then this criterion is approximately

$$g'(\mu) < -1/\gamma.$$

Deduce from the form of the graph of  $g(u)$  that periodic solutions will exist in a range  $\mu_- < \mu < \mu_+$ .

What might the instability region be in the  $(\mu, \delta)$  plane?

4.4 The dimensionless two-pool model of CICR,

$$\begin{aligned}u_t + \gamma v_t &= \mu - u, \\ \varepsilon v_t &= f(u, v),\end{aligned}$$

is considered in a one-dimensional spatial domain. Explain why the model may be modified by a diffusion term in  $u$  but not in  $v$ , and explain also why the natural length scale to choose is such that the scaled term is  $\varepsilon u_{xx}$ .

Supposing that  $f(u, v) = 0$  defines a function  $v = g(u)$  with  $g(0) = 0$ ,  $g' > 0$  for  $u < \mu_1$ ,  $u > \mu_2$ , and  $g' < 0$  for  $\mu_1 < u < \mu_2$ , where  $\mu_2 > \mu_1 > 0$ , use phase plane analysis to show plausibly that periodic travelling wave trains will exist for  $\mu_- < \mu < \mu_+$ , where  $g'(\mu_{\pm}) = -1/\gamma$  (assuming  $\min g' < -1/\gamma$ ).

Will such waves exist in two or three dimensions?

# Chapter 5

## The electrochemical action of the heart

The purpose of the heart is to pump blood through the body. The blood carries nutrients to the tissues and carries away waste products; principally, the nutrient is oxygen ( $O_2$ ) and the waste is carbon dioxide ( $CO_2$ ). Exchange of these gases between the body and the atmosphere occurs via respiratory exchange at the lungs, and is effected by a perfusion of the blood through a *capillary bed* in the pulmonary circulation.

There are two parts of the heart function which we will focus on in these notes. The first is the electrochemical action of the heart, that is to say, the way in which electrochemical signals cause muscle contraction in the *myocardium*, which enables the heart to pump blood round the body. The second is the mechanical action of the heart, i. e., the way in which this contraction enables a uni-directional circulation of the blood via a system of valves in the heart. We deal with the electrochemical action in this chapter, and the pump action in the next.

### 5.1 Action potentials and the heart beat

The heart contains four chambers, comprising two atria and two ventricles. Blood collects in the atria and is pumped to the ventricles, which in turn pump the blood to the lungs and around the body. For the heart to act effectively it is necessary for the sequence of contraction of the chambers to be synchronised. This is achieved by electrical signals (cardiac action potentials) which are transmitted through the myocardium (see figure 5.1). The heart is made of billions of individual cells. Each cell is surrounded by a membrane which is electrically polarised (the membrane potential). The electrical signals that stimulate contraction cause the membrane potential to depolarise and a second electrical signal repolarises the membrane. The *electrocardiogram* (ECG) is a measurement of these electrical signals on the surface of the body and consists of a series of waves (see figure 5.2).

Each wave in the ECG is linked with a depolarisation wave or a repolarisation wave

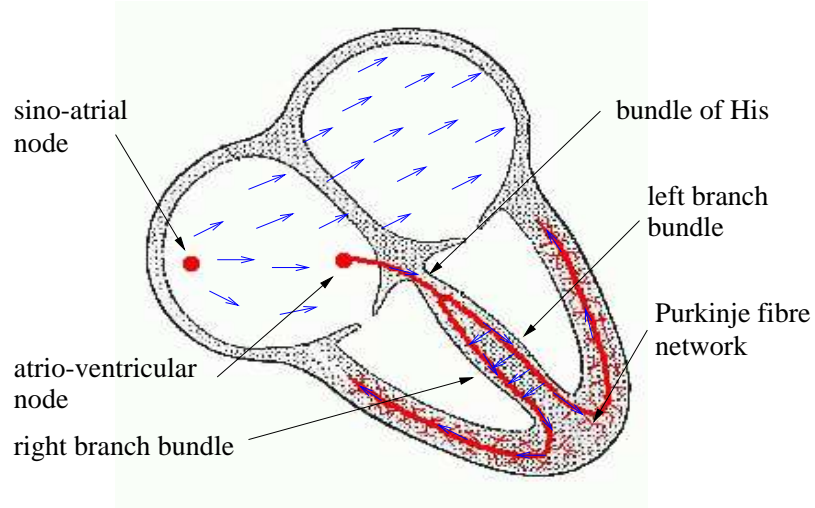

Figure 5.1: The electric pathways in the heart. The red lines are the Purkinje fibre network, and the blue arrows show the direction of the electric signal (adapted from Houghton and Gray (1997)).

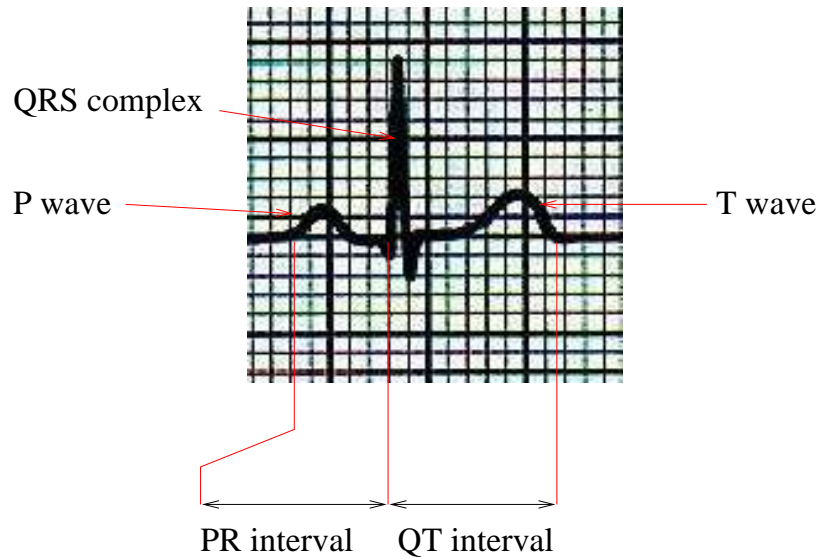

Figure 5.2: The electrocardiogram viewed from lead-I. The separate P wave, QRS complex and T wave, signifying atrial depolarisation, ventricular depolarisation and ventricular repolarisation respectively, are clearly visible (adapted from Houghton and Gray (1997)).

in the atria or ventricles. The first wave is the *P-wave* and is caused by a depolarisation wave in the atria which originates from the sino-atrial (SA) node (figure 5.1). The sino-atrial node is an electrical oscillator which is the heart's pacemaker. The second wave is the *QRS-complex* and is caused by the ventricles depolarising. There is a gap between the P-wave and QRS-complex (the PR interval) which is due to a pause in the transmission of the the depolarisation wave in the atrio-ventricular (AV) node. The depolarisation wave is transmitted rapidly though the ventricles by the Purkinje fibre network which leads to the whole ventricle contracting simultaneously. The final wave is the *T-wave* which is caused by the ventricles repolarising.

## 5.2 Cardiac cells

Similarly to neurons (see chapter 2), cardiac cells are electrically active. There are five main types of heart cells, each type fulfilling a specific function. The cells are listed below in the order in which they depolarise during a cardiac activation sequence:

1. *Sino-atrial node cells* are the pacemakers of the heart, and have oscillatory action potentials. SA node cells do not contract. The SA node is situated on the right atrium.
2. *Atrial myocytes* are excitable cells which conduct the action potential (the P-wave) with a velocity of about  $0.5 \text{ m s}^{-1}$ . Atrial myocytes are muscle cells and contract when their membrane potential is depolarised.
3. *Atrio-ventricular node cells* are excitable cells which conduct action potentials with a velocity of about  $0.05 \text{ m s}^{-1}$ . The main role of the AV node is to create a pause between the contraction of the atria and ventricles (the PR-interval). However, if the SA node fails, then the AV node can take over as the pacemaker.
4. *Purkinje fibres* are excitable cells and conduct the action potential rapidly (at about  $5 \text{ m s}^{-1}$ ). After the action potential has passed through the AV-node, the rapid conduction in the Purkinje fibres makes the depolarisation of the ventricles synchronous (this is why the QRS-complex is narrow).
5. *Ventricular myocytes* are excitable cells which conduct the action potential slowly (at about  $0.5 \text{ m s}^{-1}$ ). Ventricular cells are muscle cells and contract when their membrane potential is depolarised.

In the following sections, we shall see how the underlying ionic currents give rise to the distinctive action potentials of the SA-node cells and of the ventricular myocytes. The Nernst potentials for the different sodium, potassium and calcium in cardiac cells are approximately  $V_{\text{Na}} = 60 \text{ mV}$ ,  $V_{\text{K}} = -95 \text{ mV}$  and  $V_{\text{Ca}} = 130 \text{ mV}$ .

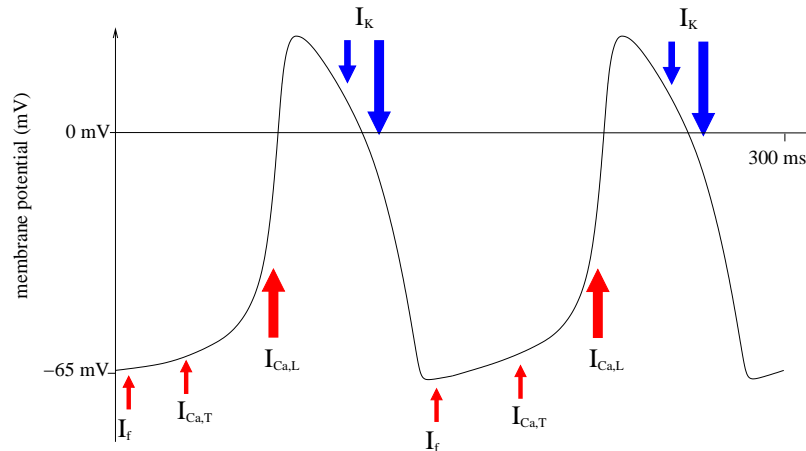

Figure 5.3: The action potential and principal ionic currents of the SA node cells. The upward arrows represent depolarising currents, the downward arrows represent repolarising currents, and the size of an arrow represents the relative size of the current.

### 5.2.1 Sino-atrial node cells

The SA-node is the pacemaker of the heart, due to the fact that the SA-node cells have oscillatory action potentials. The action potential contains three principal depolarising ionic currents and one principal repolarising current. Note that depolarising currents are also called inward currents, and cause the membrane potential to increase, while repolarising currents are also called outward or rectifying currents and cause the membrane potential to decrease. Each of the ionic currents is voltage-gated (see chapter 2) and they act at different times during the action potential (see figure 5.3).

The main currents are the following:

1.  $I_f$  is the ‘funny’ depolarising current. This depolarising current is activated (i. e., it contains voltage-gates which open) at low potentials ( $\approx -65$  mV) and it occurs at the beginning of the depolarising phase of the action potential.
2.  $I_{Ca,T}$  is the transient  $Ca^{2+}$  current, which contributes to the depolarisation at potentials between  $-60$  mV and  $-45$  mV. At higher potentials it is inactivated.
3.  $I_{Ca,L}$  is the long-lasting  $Ca^{2+}$  current and is the most important pacemaking current. The current is activated when the membrane potential rises above  $-55$  mV.
4.  $I_K$  is the time-dependent potassium current. This current is responsible for the repolarisation of the action potential and is activated when the potential rises above  $-40$  mV. However, the voltage-gates take approximately 100 ms to fully open.

Individual isolated SA node cells oscillate with different time periods (between 170 ms and 350 ms). However, in the SA node neighbouring cells are electrically coupled, which synchronises their action potentials. The SA node is electrically coupled to the right atrium which allows the action potential to spread from the SA node. This electrical coupling has a second effect: during the initial depolarisation phase it acts as a current sink, which slows the rate of depolarisation and thus reduces the frequency of the pacemaker. The frequency of the pacemaker can be increased by increasing the size of the depolarising current  $I_{Ca,L}$ ,  $I_{Ca,T}$  and  $I_f$ . For example catecholamines (for example adrenaline and noradrenaline), which are neurotransmitters released when the sympathetic nerves are stimulated, dramatically increase  $I_{Ca,L}$  and can increase the frequency of the pacemaker by a factor of three. Conversely, acetylcholine (ACh), which is a neurotransmitter released when the parasympathetic nerves are stimulated, reduces both  $I_{Ca,L}$  and  $I_f$ , and decreases the frequency of the pacemaker. Nervous control of the heart is discussed in detail in chapter 6.

### 5.2.2 Ventricular myocytes

The ventricular muscle is made of billions of individual ventricular myocytes. The ventricles contract when all the myocytes contract simultaneously. The electrophysiology of ventricular myocytes therefore must play two rôles. First, it must allow electrical signals to pass between the cells to synchronise the contractions, and second, it must stimulate the contraction. The resting potential for ventricular myocytes is typically  $-90$  mV, which is close to the Nernst potential for the potassium ions. The principal currents involved in the ventricular action potential are shown in figure 5.4. The action potential starts with a rapid depolarisation phase which is followed by the long plateau phase where the potential changes slowly. After approximately 300 ms the plateau phase ends and the cell membrane rapidly repolarises. The exact make-up and balance of the ionic currents during the plateau phase is still an area of active research and is known to differ between species.

1.  $I_{Na}$  is the fast inward sodium current which is the main current during the depolarisation phase. As the membrane potential rises above  $-65$  mV, this current is rapidly activated and then deactivated by voltage-gates. The current is very large leading the membrane to depolarise fully in less than 1 ms.
2.  $I_{to}$  is the transient outward current which causes a small but rapid repolarisation immediately after the initial depolarisation.
3.  $I_{Ca,L}$  is the long-lasting  $Ca^{2+}$  current which is a depolarising current. It is activated when the potential rises above  $-40$  mV, and is deactivated by the increased intracellular  $Ca^{2+}$  during an action potential and the membrane potential. The current triggers the release of  $Ca^{2+}$  from the *sarcoplasmic reticulum*, which is the internal store of  $Ca^{2+}$  (see chapter 4). This process is called calcium-induced calcium release (CICR) and is essential in electro-contraction



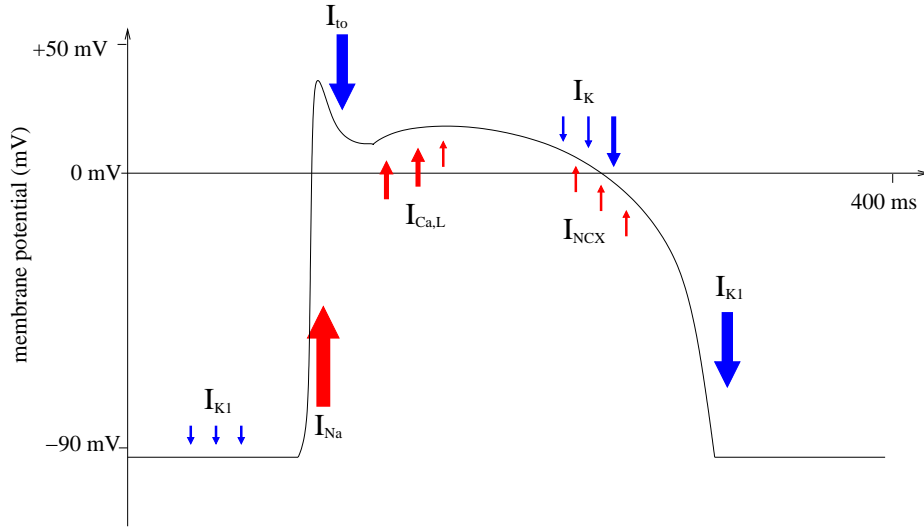

Figure 5.4: The action potential and principal ionic currents of the ventricular myocyte. The upward arrows represent depolarising currents, the downward arrows represent repolarising currents, and the size of an arrow represents the relative size of the current.

coupling (E-C coupling) because the high levels of  $\text{Ca}^{2+}$  it produces cause the cell to contract.

4.  $I_{\text{NCX}}$  is the sodium-calcium exchanger and is responsible for removing  $\text{Ca}^{2+}$  ions from the cell (note  $\text{Ca}^{2+}$  enters the cell via  $I_{\text{Ca,L}}$ , so it must eventually be removed in order to prevent a build up of  $\text{Ca}^{2+}$ ). The  $I_{\text{NCX}}$  pumps  $\text{Ca}^{2+}$  against the concentration gradient (the extracellular  $[\text{Ca}^{2+}]$  is over 10,000 times greater than the intracellular  $[\text{Ca}^{2+}]$ ) by allowing three sodium ions to enter the cell for each calcium ion which is removed. When  $\text{Ca}^{2+}$  is being removed from the cell there is a net inward current which helps to maintain the action potential.
5.  $I_{\text{K}}$  is the outward potassium current which is a repolarisation current. During the plateau phase it balances the inward  $I_{\text{Ca,L}}$  and  $I_{\text{NCX}}$ .
6.  $I_{\text{K}_1}$  is the background potassium current and is a repolarisation current which is inactivated at high membrane potentials. It is responsible for the rapid repolarisation at the end of the plateau phase and for maintaining the resting potential.

The plateau phase ends when the outward currents  $I_{\text{K}}$  and  $I_{\text{K}_1}$  become larger than the balancing inward currents  $I_{\text{Ca,L}}$  and  $I_{\text{NCX}}$ .

Mathematical models (e. g., the Beeler-Reuter, Noble, or Luo-Rudy models) of cardiac cells can be constructed describing these ionic currents and their associated voltage-gates. These models are similar to the Hodgkin-Huxley model for nerve cells,

but involve more variables due to the greater number of currents involved. However, the basic feature of cardiac cells is that they are excitable and that the upstroke of the action potential is much more rapid than repolarisation during the plateau phase. The FitzHugh-Nagumo model (chapter 2) also has these properties and can be used as a first approximation to model cardiac action potential. The FHN equations are

$$\begin{aligned}\varepsilon \frac{dv}{dt} &= f(v) - w, \\ \frac{dw}{dt} &= \gamma v - w,\end{aligned}\tag{5.1}$$

where  $f(v)$  contains two stable roots and is often represented by a cubic equation.  $v$  is the membrane potential and  $w$  is the recovery variable.

### 5.3 Cardiac tissue

Ventricular myocytes are very small, typically only  $100\ \mu\text{m}$  long and  $10\ \mu\text{m}$  wide. The heart muscle is made of billions of interconnected ventricular myocytes which divide the tissue into two regions: the intracellular space and the extracellular space. The myocytes are aligned approximately parallel to each other defining the *fibre direction*. The fibre structure of cardiac tissue makes it anisotropic. Adjacent cells form connections in regions called *intercalated discs*. Within these discs are *gap junctions*, which form electrical connections between the cells. The majority of the gap junctions are concentrated at the ends of the cells, leading to a larger electrical conductivity in the direction of the cardiac fibres compared with the direction perpendicular to the fibres. In theory it is possible to write down equations that model the fine structure of the intercellular connections, however, in practice solving these equations is computationally impossible. The length scale over which the potential varies is greater than the microscopic length scale of the cellular structure, and therefore homogenisation techniques can be used to yield a continuum description of the tissue (see Keener and Sneyd (1998, p. 327)). The intracellular and extracellular potential are given by  $V_i(\mathbf{x}, t)$  and  $V_e(\mathbf{x}, t)$  respectively, so the transmembrane potential is  $V = V_i - V_e$ . The intracellular and extracellular current densities are given by  $\mathbf{J}_i$  and  $\mathbf{J}_e$  respectively, and are assumed to be ohmic, so that

$$\mathbf{J}_i = -\boldsymbol{\sigma}_i \nabla V_i \quad \text{and} \quad \mathbf{J}_e = -\boldsymbol{\sigma}_e \nabla V_e,\tag{5.2}$$

where  $\boldsymbol{\sigma}_i$  and  $\boldsymbol{\sigma}_e$  are the intracellular and extracellular conductivity (second rank) tensors. The total current at each point is given by  $\mathbf{J}_{\text{tot}} = \mathbf{J}_i + \mathbf{J}_e$ . Assuming no external currents are applied, the total current is conserved, so that

$$\nabla \cdot \mathbf{J}_{\text{tot}} = \nabla \cdot (\boldsymbol{\sigma}_i \nabla V_i + \boldsymbol{\sigma}_e \nabla V_e) = 0.\tag{5.3}$$

Although the total current is conserved, the individual currents in the extracellular and intracellular spaces are not conserved because of the transmembrane current and

the capacitive current across the cell membrane. The transmembrane current per unit area of membrane is  $I_m$ , and

$$I_m = C_m \frac{\partial V}{\partial t} + I_{\text{ion}} = \frac{1}{\chi} \nabla \cdot (\boldsymbol{\sigma}_i \nabla V_i), \quad (5.4)$$

where  $\chi$  is the surface area to volume ratio of the cell membrane. Equations (5.3) and (5.4) form the bidomain model for cardiac tissue. The bidomain model can be reduced to a monodomain model in the special case that the intracellular and extracellular conductivities are proportional, so that  $\boldsymbol{\sigma}_e = k\boldsymbol{\sigma}_i$  where  $k$  is a constant. Eliminating  $\boldsymbol{\sigma}_e$  and  $V_e$  from (5.3) yields

$$\nabla \cdot (\boldsymbol{\sigma}_i \nabla V_i) = \nabla \cdot (\boldsymbol{\sigma} \nabla V), \quad (5.5)$$

where  $\boldsymbol{\sigma} = k\boldsymbol{\sigma}_i/(1+k)$ . Inserting this expression into (5.4) yields the single monodomain equation

$$\nabla \cdot (\boldsymbol{\sigma} \nabla V) = \chi \left( C_m \frac{\partial V}{\partial t} + I_{\text{ion}} \right). \quad (5.6)$$

We will use a version of the monodomain model to examine the propagation of wavefronts in two dimensions.

## 5.4 Wave propagation in two dimensions

In this section a geometrical theory of wave propagation is introduced which allows the study of wave propagation in more than one dimension. To be specific, we will consider periodic travelling wave trains, which, as shown in chapter 4, are the common consequence of adding diffusion to oscillatory reaction kinetics. The propagation of solitary waves in this context can be understood as a limit in which the period of the underlying limit cycle tends to infinity. The theory is based on the assumption that the spatial variation of the wave is slow, in a sense we make specific below.

Suppose that a vector of concentrations  $\mathbf{w}$  satisfies the general (non-dimensional) reaction-diffusion equation

$$\mathbf{w}_t = \mathbf{f}(\mathbf{w}) + \nabla^2 \mathbf{w}, \quad (5.7)$$

where  $\mathbf{w} \in \mathbf{R}^n$ . In the simplest case  $n = 2$ , and while it is not necessary that the diffusivities of the different species are all the same, it is simpler to suppose this for the purposes of exposition.

Suppose that the reaction kinetics admit an attractive limit cycle for the underlying system  $\mathbf{w}_t = \mathbf{f}(\mathbf{w})$ , and denote this as  $\mathbf{W}_0(t)$ , i. e.,

$$\mathbf{W}'_0 = \mathbf{f}(\mathbf{W}_0). \quad (5.8)$$

Suppose further that we look for solutions which are slowly varying in space. We define slow time and space scales  $\tau$  and  $\mathbf{X}$  as

$$\tau = \varepsilon t, \quad \mathbf{X} = \sqrt{\varepsilon} \mathbf{x}, \quad (5.9)$$

and seek formal solutions of (5.7) in the form  $\mathbf{w}(\mathbf{X}, t, \tau)$ , where

$$\mathbf{w}_t + \varepsilon \mathbf{w}_\tau = \mathbf{f}(\mathbf{w}) + \varepsilon \nabla^2 \mathbf{w}, \quad (5.10)$$

and  $\nabla = \nabla_{\mathbf{X}}$  now. Expanding  $\mathbf{w}$  as

$$\mathbf{w} \sim \mathbf{w}_0 + \varepsilon \mathbf{w}_1 + \dots \quad (5.11)$$

leads to

$$\begin{aligned} \mathbf{w}_{0t} &= \mathbf{f}(\mathbf{w}_0), \\ \mathbf{w}_{1t} - J\mathbf{w}_1 &= -\mathbf{w}_{0\tau} + \nabla^2 \mathbf{w}_0, \end{aligned} \quad (5.12)$$

and so on; here  $J = D\mathbf{f}(\mathbf{w}_0)$  is the Jacobian of  $\mathbf{f}$  at  $\mathbf{w}_0$ . After an initial transient, we may take

$$\mathbf{w}_0 = \mathbf{W}_0(t + \psi), \quad (5.13)$$

where  $\psi(\tau, \mathbf{X})$  is the slowly-varying phase, and the Jacobian  $J = D\mathbf{f}(\mathbf{W}_0)$  is a time-periodic matrix. Thus we find that  $\mathbf{w}_1$  satisfies

$$\mathbf{w}_{1t} - J\mathbf{w}_1 = -(\psi_\tau - \nabla^2 \psi) \mathbf{W}'_0 + |\nabla \psi|^2 \mathbf{W}''_0. \quad (5.14)$$

Note that  $\mathbf{s} = \mathbf{W}'_0$  satisfies the homogeneous equation  $\mathbf{s}_t - J\mathbf{s} = \mathbf{0}$ . It follows that the solution of (5.14) is

$$\mathbf{w}_1 = -t(\psi_\tau - \nabla^2 \psi) \mathbf{s} + |\nabla \psi|^2 \mathbf{u}, \quad (5.15)$$

where

$$\mathbf{u} = M(t) \int_0^t M^{-1}(\theta) J(\theta) \mathbf{s}(\theta) d\theta + M(t), \quad (5.16)$$

and  $M$  is a fundamental matrix for the homogeneous equation, i. e.,  $M' = JM$ ,  $M(0) = I$ . Floquet's theorem implies that

$$M = P e^{t\Lambda}, \quad (5.17)$$

where  $P$  is a periodic matrix of period  $T$  (the same as that of the limit cycle  $\mathbf{W}_0$ ). We can take the matrix  $\Lambda$  to be diagonal if the characteristic multipliers are distinct, and since we assume  $\mathbf{W}_0$  is attracting, the eigenvalues of  $\Lambda$  will all have negative real part, except one of zero corresponding to  $\mathbf{s}$ . With a suitable choice of basis, we then have

$$(e^{t\Lambda})_{ij} \rightarrow \delta_{i1} \delta_{j1} \quad \text{as } t \rightarrow \infty, \quad (5.18)$$

i. e., a matrix with the single non-zero element being unity in the first element. In this case the first column of  $P$  is  $\mathbf{s}$ , i. e.,  $P_{i1} = s_i$ .

From (5.16), we have

$$\mathbf{u} = P(t) \int_0^t e^{\eta\Lambda} P^{-1}(t - \eta) J(t - \eta) \mathbf{s}(t - \eta) d\eta + M\mathbf{c}. \quad (5.19)$$

The effect of the transient dies away as  $t \rightarrow \infty$ , and if we ignore it, then we can take  $M_{ij} = s_i \delta_{j1}$ , whence  $M\mathbf{c} = c_1 \mathbf{s}$ , and thus

$$\mathbf{u} = \mathbf{s} \left[ \int_0^t \alpha(\eta) d\eta + c_1 \right], \quad (5.20)$$

where the periodic function  $\alpha$  is given by<sup>1</sup>

$$\alpha = (P^{-1})_{1m} J_{mj} s_j. \quad (5.21)$$

We define the mean of  $\alpha$  to be

$$\bar{\alpha} = \frac{1}{T} \int_0^T \alpha(\eta) d\eta, \quad (5.22)$$

so that

$$\beta = \int_0^t (\alpha - \bar{\alpha}) d\eta \quad (5.23)$$

is periodic with period  $T$ . Then (5.15) is

$$\mathbf{w}_1 = [t\{-\psi_\tau + \nabla^2 \psi + \bar{\alpha} |\nabla \psi|^2\} + c_1 + \beta] \mathbf{s}, \quad (5.24)$$

and in order to suppress secular terms (those which grow in  $t$ ), we require the phase  $\psi$  to satisfy the evolution equation

$$\psi_\tau = \nabla^2 \psi + \bar{\alpha} |\nabla \psi|^2. \quad (5.25)$$

This is an integrated form of Burgers' equation; in one dimension,  $u = -\psi_X/2\bar{\alpha}$  satisfies  $u_\tau + uu_X = u_{XX}$ . Disturbances will form shocks, which are jumps of phase gradient. More generally, if  $\mathbf{u} = -\nabla \psi/2\bar{\alpha}$ , then (bearing in mind that  $\nabla \times \mathbf{u} = \mathbf{0}$ ) we find

$$\mathbf{u}_\tau + (\mathbf{u} \cdot \nabla) \mathbf{u} = \nabla^2 \mathbf{u}, \quad (5.26)$$

which is the Navier-Stokes equation with no pressure term. Phase gradients move down phase gradients, and form defects where the (sub-)characteristics intersect.<sup>2</sup>

## 5.5 Target patterns

Solutions of (5.25) which vary with  $\mathbf{X}$  correspond to travelling wave trains. For example, in one dimension, waves travel locally at speed  $dX/dt \approx -(\partial\psi/\partial X)^{-1}$ . In the heart, a more relevant situation is to suppose that, by analogy with the SA node pacemaker,  $\psi$  is prescribed at a central nucleus, which we take to be the origin. In

<sup>1</sup>We use the summation convention, which implies summation over repeated suffixes.

<sup>2</sup>Physicists call (5.25) the KPZ equation (after Kardar *et al.* (1986)). The substitution  $u = \exp(\bar{\alpha}\psi)$  reduces it to the diffusion equation for  $u$ ; this is the Hopf-Cole transformation (see Whitham 1974).

this case, *target patterns* are formed; these are circular wavefronts which originate from a point. To be specific, suppose that

$$\psi = \tau \quad \text{at} \quad r = b, \quad (5.27)$$

where  $r$  is the polar radius; we then seek a solution  $\psi = \tau - f(r)$ , where  $f$  satisfies

$$f'' + \frac{1}{r}f' - \bar{\alpha}f'^2 + 1 = 0, \quad (5.28)$$

together with  $f(b) = 0$  and an appropriate condition at large  $r$ ; this is prescribed by restricting attention to a target pattern originating near the origin and thus suppressing incoming waves (this is known as a radiation condition). The relevant solution if  $\bar{\alpha} > 0$  is

$$f(r) = -\frac{1}{\bar{\alpha}} \ln \left[ \frac{K_0(\sqrt{\bar{\alpha}}r)}{K_0(\sqrt{\bar{\alpha}}b)} \right], \quad (5.29)$$

where  $K_0$  is the modified Bessel function of the second kind of order zero. The other Bessel function  $I_0$  is suppressed because of the radiation condition (it produces incoming waves). At large  $r$ ,  $\psi \sim \tau - r/\sqrt{\bar{\alpha}}$ , which represents an outward travelling wave of speed  $dr/dt \approx \sqrt{\bar{\alpha}}$ . If, on the other hand,  $\bar{\alpha} < 0$ , then  $K_0$  is replaced by a combination of the Bessel functions  $J_0$  and  $Y_0$ , and the solution is singular at finite  $r$ , and target pattern solutions of this type do not exist. More generally, if  $\psi = \Omega\tau$  on  $r = b$ , then target patterns exist if  $\bar{\alpha}\Omega > 0$ .

### Excitable tissue

An example of a target pattern in the heart is the depolarisation wave which originates from the sino-atrial node (the pacemaker region). Further examples of target patterns occur in monomorphic ventricular tachycardia and Wolff-Parkinson-White disease. A numerical solution of the FitzHugh-Nagumo equations (using a cubic function for  $f(v)$  with stable roots at  $v = 0$  and  $v = 1$ ) showing a target pattern is shown in figure 5.5. The initial conditions used were  $v = 0$  when  $r > r_0$  and  $v = 1$  when  $r < r_0$  (i. e., a circular region of tissue was excited). When the external medium is excitable, then the initial perturbation needs to be large enough to cause propagation, otherwise it dies away: this is shown in the figure, and is associated with the existence of a critical initial patch size.

An important question to ask is how large must the sino-atrial node be for the depolarisation wave to successfully transmit from the sino-atrial node into the atria. Normally the sino-atrial node is larger than the critical value of the patch radius. However in conditions such as hyperkalaemia, when the excitability of the tissue is greatly reduced, it is possible for the wave to fail to transmit from the sino-atrial node: this is called sino-atrial block.

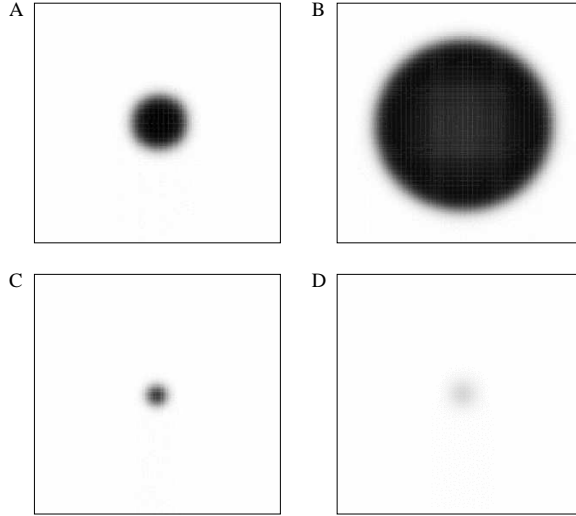

Figure 5.5: Solutions of the FitzHugh-Nagumo equation in the form  $\varepsilon v_t = f(v) + \varepsilon^2 \nabla^2 v$ , with  $f(v) = v(v - a)(1 - v)$ , showing target patterns (white is  $v = 0$ ; black is  $v = 1$ ). When a large circular wavefront is excited (A), the wave propagates outwards (B). However, when a small circular wavefront is excited (C) the wave front decreases in size (D) due to *curvature blocking*.

## 5.6 Spiral waves

*Spiral waves* are self-replicating patterns which consist of a rotating spiral and occur in the heart during certain types of polymorphic tachycardia (for example, Torsades de pointes). Figure 5.6 shows a solution of the FitzHugh-Nagumo equations exhibiting a spiral wave. The fact that spiral waves rotate means that spiral wave solutions are periodic in time.

Spiral waves are important because they lead to re-entrant behaviour without pacemaking cells. Re-entrant behaviour is when one part of tissue is continually re-excited. Spiral waves are thought to be the cause of polymorphic ventricular tachycardia. Instabilities in spiral waves can lead to them breaking-up forming multiple wavelets. This is a possible explanation for the breakdown of ventricular tachycardia into ventricular fibrillation, which is fatal if not treated immediately.

Spiral waves can also be described as solutions of (5.25). We put

$$\psi = \Omega\tau + m\theta - g(r), \quad (5.30)$$

where  $m$  is an integer, associated with an appropriate boundary condition at a central ‘dead’ core at  $r = b$ . Again we require  $\bar{\alpha}\Omega > 0$ , and the solution, if we suppose  $\Omega > 0$ , is

$$g(r) = -\frac{1}{\bar{\alpha}} \ln \left[ \frac{K_\nu(\sqrt{\bar{\alpha}\Omega}r)}{K_\nu(\sqrt{\bar{\alpha}\Omega}b)} \right], \quad \nu = i\alpha m, \quad (5.31)$$

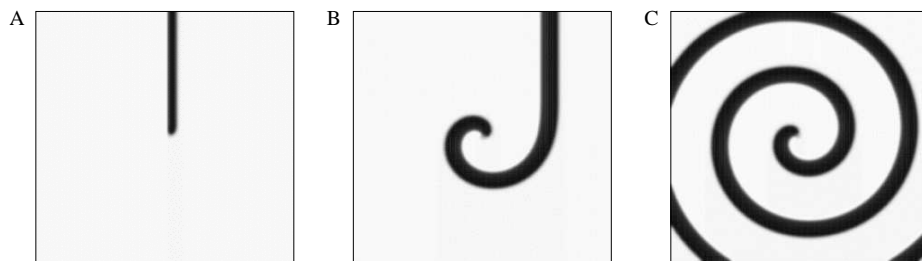

Figure 5.6: Solutions of the FitzHugh-Nagumo equations as in figure 5.5 showing spiral waves (white is  $v = 0$ ; black is  $v = 1$ ). The initial condition (A) is a plane wave in half the domain which wraps around a central core forming a re-entrant spiral wave (C) which continues to re-excite the tissue. In the centre of the domain is a core consisting of a small disk of ‘dead tissue’ (where  $f(v) = 0$ ) which pins the spiral wave to the centre.

if we suppose  $g = 0$  at  $r = b$ . If  $\Omega < 0$ , we select the modified Bessel function  $I_0$  instead of  $K_0$  (to maintain the radiation condition). At large  $r$ ,

$$\psi \sim \Omega\tau + m\theta - \sqrt{\frac{\Omega}{\bar{\alpha}}}r. \quad (5.32)$$

This is an Archimedean spiral, which winds outward clockwise if  $m > 0$ , and then rotates anti-clockwise. In practice, and as shown in figure 5.6, the existence of spiral waves is associated with a core which allows the maintenance of a travelling wave circulating round its boundary.

## 5.7 Notes and references

Brown and Kozłowski (1997)  
 Houghton and Gray (1997)  
 Keener and Sneyd (1998)  
 Grindrod (1991)

## Exercises

5.1



# Chapter 6

## The heart as a pump

The rhythmic contraction of the heart described in the preceding chapter causes blood to be expelled into the arterial system. The heart, together with the *arteries* (which carry oxygenated blood to the tissues) and the *veins* (which carry the de-oxygenated blood back to the heart), forms a closed system of some five litres in volume, and in order for contraction of the heart to effect a one way pulsatile flow, a system of valves is necessary in order to prevent back flow. In this chapter we describe this system, and also how it is controlled.

### 6.1 The circulation

A semi-schematic illustration of the human circulation is shown in figure 6.1. Blood is pumped from the heart through the pulmonary capillary bed, where gas exchange in the *alveoli* of the lung (described in chapter 7) removes metabolically produced carbon dioxide and charges the blood with oxygen. The red, oxygenated blood returns to the heart where it is then pumped to the tissues of the body via the arteries; the blood dumps its oxygen in the tissues, and acquires a load of CO<sub>2</sub>, which it takes back to the heart in the veins.

In order to function in this way, the heart really consists of two parts, the right heart (which sends the blood to the lungs) and the left heart (which sends the blood to the tissues). Each side consists of an atrium, where the incoming blood is stored, and a ventricle, where the blood is pumped. Thus the heart contains four chambers: the right and left atria, and the right and left ventricles. The wall between the left and right ventricles is called the septum.

The detailed pathway taken by the blood is shown in figure 6.2; de-oxygenated blood returns to the heart through the vena cava into the right atrium. From there it is sucked into the right ventricle, before being ejected into the pulmonary artery. On returning to the heart via the pulmonary vein, the oxygenated blood flows into the left atrium, from where it is sucked into the left ventricle before being ejected into the aorta under high pressure. The ventricular walls are much thicker than the atrial walls, since they are responsible for creating the majority of the blood pressure.

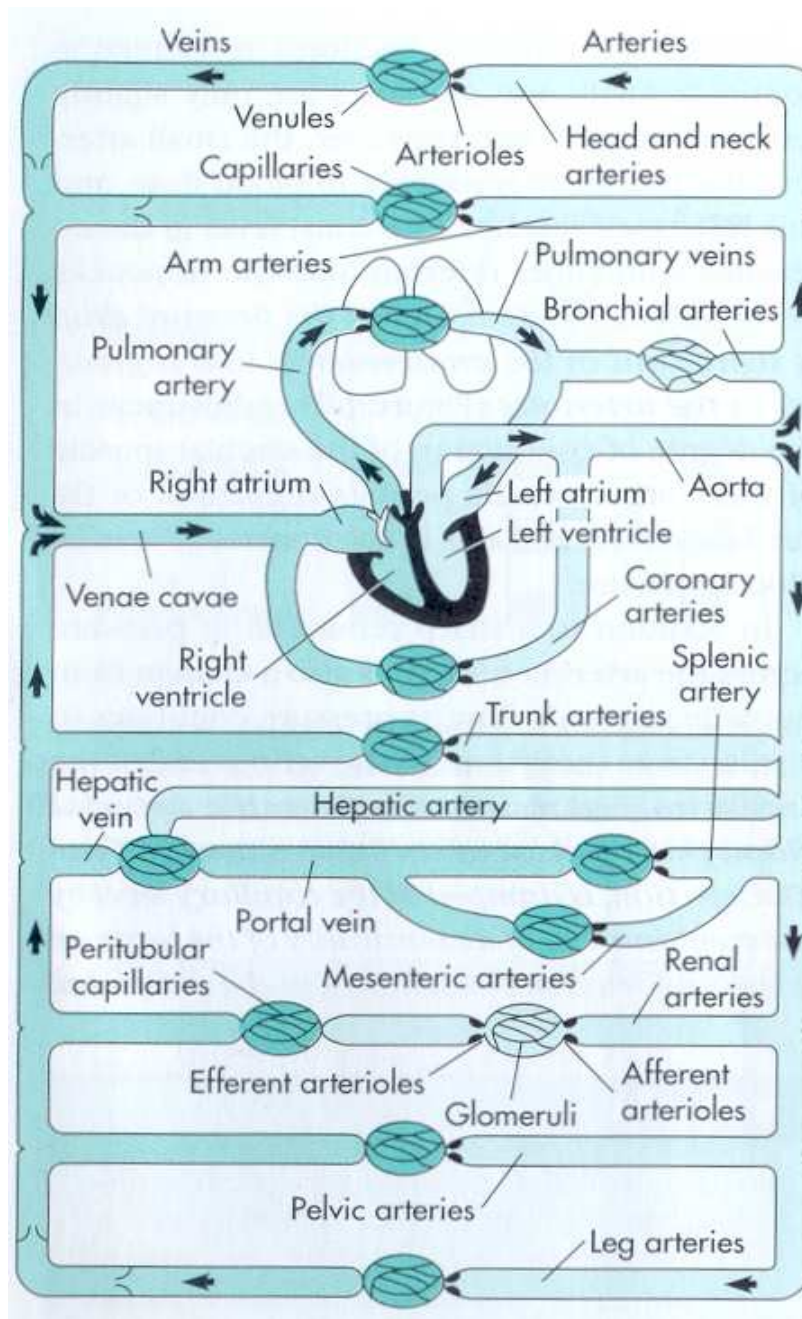

Figure 6.1: The human circulation. Blood flows from the heart to the lungs and back (the pulmonary circulation), before carrying the consequently oxygenated blood through the arteries to the tissues, and then back to the heart via the veins.

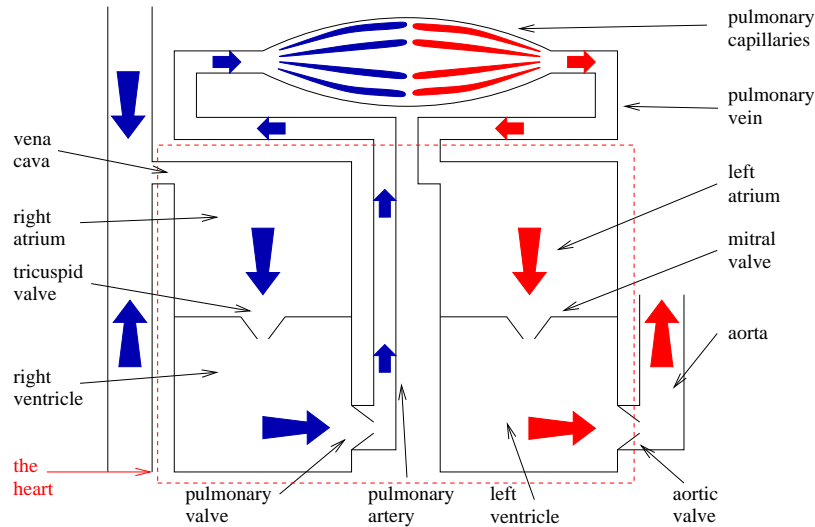

Figure 6.2: A schematic diagram of the chambers and valves of the heart, and the connecting arteries and veins. The direction of the blood flow is shown, the blue arrows represent de-oxygenated blood and the red arrows represent oxygenated blood.

Additionally the left ventricular wall is much thicker than the right ventricular wall because it is responsible for pumping blood around the whole body as opposed to just the lungs.

Fluid flow in the circulation is driven by a pressure gradient which descends from arteries to microcirculation in the tissues to veins, and because the circulation is closed, there must always be regions of contrary pressure gradient. It is precisely in order that a back flow is prevented that the heart contains valves. There are, in fact, four valves which enable the flow to proceed in the manner described above, and these are indicated in figure 6.2. The tricuspid valve prevents back-flow into the right atrium, the pulmonary valve prevents back-flow into the right ventricle, the mitral valve prevents back-flow into the left atrium, and the aortic valve prevents back-flow into the left ventricle.

Figure 6.3 indicates how pressure varies in the circulation. The left ventricular pressure varies from a maximum of about 120 mm Hg to a minimum close to zero. The pressure in the arteries also oscillates, but less dramatically, a typical range being from 80 to 120 mm Hg (hence the typical blood pressure reference as “120 over 80”). The varying pressure causes waves to propagate down the deformable arteries, but their amplitude is quickly attenuated, and the pressure drop through the capillary microcirculation is essentially constant. Moreover, it is in the capillaries that the bulk of the pressure drop occurs, because of their small diameters. Because of their small volume, one can think of the capillaries as providing (by analogy with an electrical circuit) a resistance to the flow.

The actual sequence of events in the heart itself during a heartbeat is best described with reference to the left ventricular pressure–volume diagram, which repre-

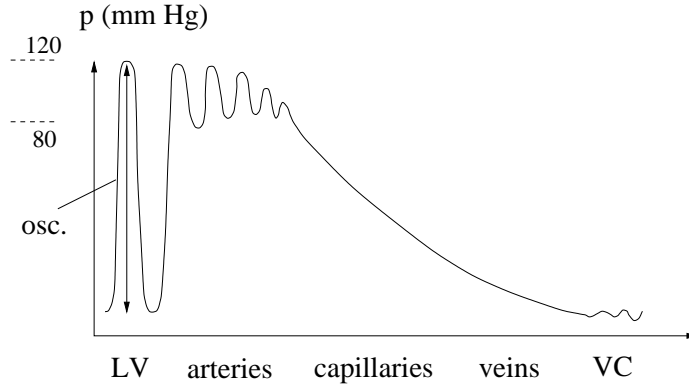

Figure 6.3: Illustration of the variation of pressure with arterial distance from the heart. LV: left ventricle; VC: Vena Cava.

sents how the pressure and volume of the left ventricle vary through the cycle. This is shown in figure 6.4. The left and right hearts act more or less synchronously, so that it suffices to describe the cycle in the left heart.

The heartbeat has two phases, called *systole* and *diastole* (the last ‘e’ is pronounced in each word). Systole refers to the contraction phase, when the ventricular pressure rises, and diastole refers to the relaxation phase, when ventricular pressure is low. Each of these phases is further subdivided, depending on whether the two left

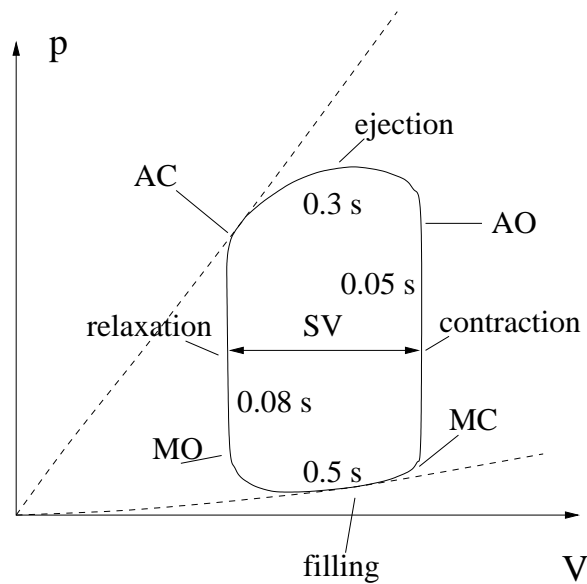

Figure 6.4: Left ventricular pressure volume diagram. AC: aortic valve closes; MO: mitral valve opens; MC: mitral valve closes; AO: aortic valve opens. SV denotes stroke volume.

ventricular valves are open or closed.

The beginning part of systole is the isovolumetric contraction phase (between MC and AO); both valves are shut, so that the volume  $V_{LV}$  of the left ventricle remains constant (because the contained blood is incompressible). In this phase the muscles of the ventricular myocardium contract because of the cardiac action potential, and as a consequence the left ventricular pressure  $p_{LV}$  increases (think of the effect of tightening a noose round your neck). This contraction phase is rapid, taking about 0.05 seconds. When the pressure increases beyond the aortic arterial pressure, the aortic valve opens and ejection of the blood into the aorta begins. Contraction continues for a further short period before the ventricular pressure starts to decline as a consequence of the ejection. During this ejection phase, of some 0.3 s duration, the ventricular volume decreases from about 120 ml to about 50 ml; the volume of ejected blood is the *stroke volume*, about 70 ml.

The end of the ejection phase usually occurs at the same time that the action potential drops, and is due to the relaxation of heart muscle as the transient intracellular calcium concentration decreases, and the crossbridges break (see chapter 5). The declining ventricular pressure decreases below the arterial pressure once again, thus closing the aortic valve. There now follows diastole: first an isovolumetric relaxation phase, during which the pressure drops sharply in a time of about 0.08 s, until the ventricular pressure decreases below the left atrial pressure. At this point (MO) the mitral valve opens (the aortic valve is still closed), and the fourth phase of the cycle, the filling phase, begins. In this the ventricle is filled from the atrium, and the ventricular volume increases once more towards its pre-systolic value. The cardiac pacemaker fires, and the cycle begins again.

## 6.2 A simple one-chamber compartment model

The simplest model of the circulation is a compartment model, in which the veins, arteries, capillary beds, and the chambers of the heart form separate compartments. The model then simply traces the volume changes of the various compartments due to the flow between them. The simplest of such models are those with the fewest compartments, and the most basic one which retains the concept of the heart as a pump is illustrated in figure 6.5. The pulmonary circulation is ignored, and the heart is taken to have a single compartment, the left ventricle. The other compartments are the veins, arteries and a capillary bed, whose primary function is in providing resistance to the flow. The capillary volume is small, and is ignored in the following discussion. In keeping with our assumption of a one chamber heart, there are only two valves, the mitral and aortic valves.

We let  $V$  and  $p$  denote chamber volumes, and suffixes  $a$ ,  $v$ , and  $LV$  refer to arteries, veins and left ventricle, respectively. Blood flow rates to and from the left ventricle are denoted by  $Q_-$  and  $Q_+$ , respectively, and the blood flow through the capillaries is denoted by  $Q_c$  (for both inflow and outflow, since we assume incompressible blood and zero capillary volume). Conservation of blood volume is then expressed by the

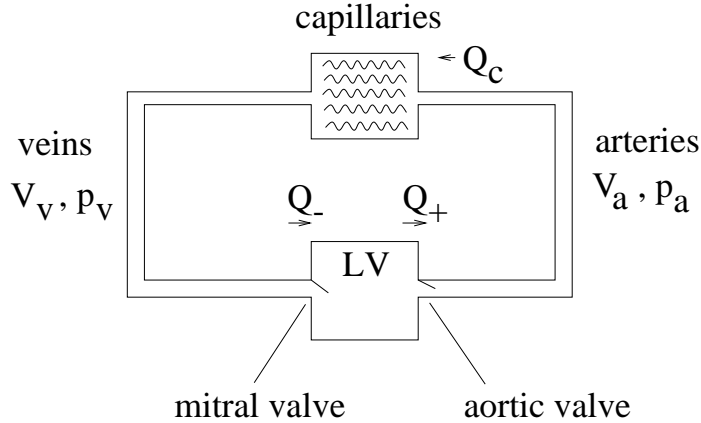

Figure 6.5: Simple compartment model of the circulation.

equations

$$\begin{aligned}
 \dot{V}_a &= Q_+ - Q_c, \\
 \dot{V}_v &= Q_c - Q_-, \\
 \dot{V}_{LV} &= Q_- - Q_+,
 \end{aligned} \tag{6.1}$$

whence evidently total blood volume is conserved.

The capillary resistance is denoted by  $R_c$ , so that the capillary blood flow is

$$Q_c = \frac{p_a - p_v}{R_c}. \tag{6.2}$$

There are also, similarly, resistances associated with the flow to and from the left ventricle. We denote these by  $R_v$  and  $R_a$ , so that

$$Q_+ = \frac{[p_{LV} - p_a]_+}{R_a}, \quad Q_- = \frac{[p_v - p_{LV}]_+}{R_v}, \tag{6.3}$$

and  $[x]_+ = \max\{x, 0\}$ ; this represents the effects of the two valves, which do not allow backflow.

The anatomically ‘correct’ figure 6.5 is not really consistent with this description, since it portrays arteries and veins as passageways. In order for (6.3) to make sense, we need to interpret  $p_a$  and  $p_v$  as pressures either side of the capillary bed, but in consideration of the arteries and veins as compartments, they need to be thought of as averages. This blurring is a necessary consequence of the neglect of spatial variation of pressure with distance along the blood vessels.

In order for incompressible blood to circulate, it is necessary that compartment volumes can change, and this is enabled by compliance of the blood vessels. This is the balloon-like property of blood vessel walls, which allows their distension under increased internal pressure. The simplest assumption is one of linear dependence, and

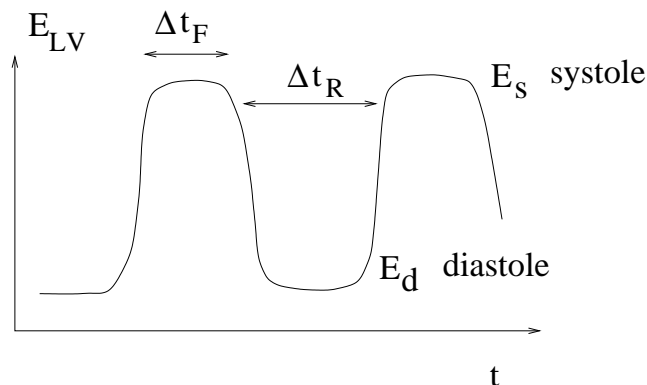

Figure 6.6: Effect of periodic ventricular contraction on elastance.

thus we write

$$\begin{aligned}
 V_a &= V_{a0} + C_a p_a, \\
 V_v &= V_{v0} + C_v p_v, \\
 V_{LV} &= V_0 + C_{LV} p_{LV},
 \end{aligned}
 \tag{6.4}$$

and the quantities  $C_k$  are called *compliances*. Their inverses ( $E_k = 1/C_k$ ) are called *elastances*, and we will use elastance in discussing left ventricular volume.

This completes the simple mechanical description of the circulation, except that the driving force for the heart beat is not present. As described in chapter 5, the heart beat consists of a ventricular contraction, driven by the passage of a wave of contraction through the atria and ventricles which originates in the sino-atrial node. This periodic firing, and the resulting contraction of heart muscle, causes a stiffening of the ventricles (one should think of the effect of tightening a noose round the neck), and this reduces ventricular compliance. Thus the regular firing and consequent contraction of the ventricles causes a periodic change in ventricular elastance, which we suppose to take the form shown in figure 6.6. Essentially the elastance jumps from a very low value  $E_d$  to a very high value  $E_s$ , and back, with a period of about 0.9 s.

### 6.2.1 An approximate solution

The model above is simple but nevertheless nonlinear. We are hoping that its solution will mimic the observed pressure-volume cycle shown in figure 6.4. This is shown again in figure 6.7, where also we indicate the way the arterial and venous pressures cycle. The heart valves open and close where these latter two curves touch the ventricular pressure curves. Note that the (aortic) arterial pressure cycles between values of 120 and 80 mm Hg, whereas the venous pressure is much lower, around 10 mm Hg. Figure 6.8 shows how these pressures vary with time, together with left ventricular volume and the ECG.

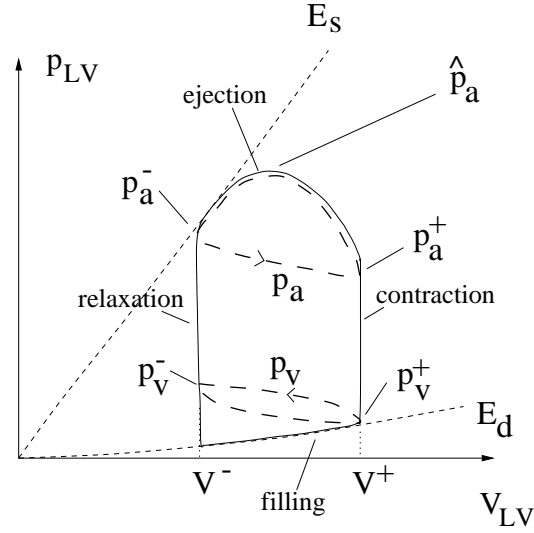

Figure 6.7: Left ventricular pressure-volume curve, showing also arterial and venous pressures.  $p_a^+$  is the end diastolic arterial pressure,  $V^+$  is the corresponding left ventricular volume. The diagram is idealised on the assumption that ventricular elastance shuttles rapidly between two constant values. More realistically, left ventricular pressure follows a curved path during ejection and filling, similar to that shown in figure 6.4.

The equations (6.1)–(6.4) combine to give the model

$$\begin{aligned}
 R_c C_a \dot{p}_a &= -(p_a - p_v) + \frac{R_c}{R_a} [p_{LV} - p_a]_+, \\
 R_c C_v \dot{p}_v &= (p_a - p_v) - \frac{R_c}{R_v} [p_v - p_{LV}]_+, \\
 \left( \frac{\dot{p}_{LV}}{E_{LV}} \right) &= \frac{[p_v - p_{LV}]_+}{R_v} - \frac{[p_{LV} - p_a]_+}{R_a},
 \end{aligned} \tag{6.5}$$

in which  $E_{LV}$  varies between the diastolic value  $E_d$  and the systolic value  $E_s$ , as shown in figure 6.6. Typical values of the parameters are given in table 6.1.

There are some notable features of the values in table 6.1. Most of the blood volume resides in the venous system, which, with its large compliance, is like a large soggy bag. The venous system is like an air mattress, while the arterial system is like the bicycle pump with which you blow it up (and then the capillary system is the nozzle of the pump). It is because of this disparity that the arterial pressure is so high, while the venous pressure sits round a pressure of about 8 mm Hg, and is more or less constant at this level. Another feature is the high value of the capillary resistance compared with those of arteries and veins. It is a consequence of this that the left ventricular pressure is close to the arterial pressure when the aortic valve is open, and to the venous pressure when the mitral valve is open, as shown in figure 6.8. Finally, we notice the extreme change in the left ventricular elastance between



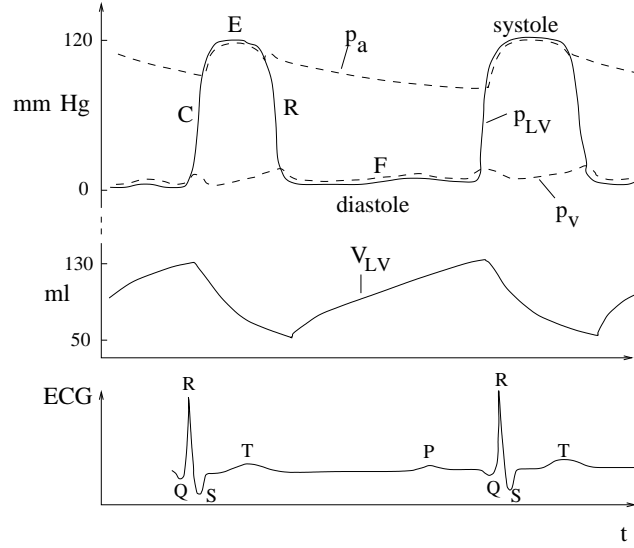

Figure 6.8: Arterial, venous, and left ventricular pressures as a function of time through the heart beat. Also shown is the left ventricular volume, and the ECG. The letters  $C$ ,  $R$ ,  $E$  and  $F$  on the pressure curves stand for contraction, relaxation, ejection and filling, respectively. Wiggles in the pressure curves are associated with valve closure, in particular the *dicrotic notch* in the arterial curve at the end of ejection, when the aortic valve closes.

diastole and systole. These dramatic variations in the parameters will allow us to derive approximate solutions of the model. We now seek to do this by solving for each of the four phases of the heart beat in turn.

### Isovolumetric contraction

We suppose, to begin with (see figure 6.7), that  $p_v < p_{LV} < p_a$ , so that both valves are shut, and  $Q_{\pm} = 0$ . We suppose that the end diastolic arterial and venous pressures are  $p_a^+$  and  $p_v^+$  respectively, and that contraction has just commenced, with the left ventricular volume being  $V^+$ . Because  $p_v \ll p_a$ , arterial pressure is approximately determined by

$$\dot{p}_a \approx -\frac{p_a}{R_c C_a}. \quad (6.6)$$

From table 6.1,  $R_c C_a \approx 1.8$  s, while the contraction phase is of duration 0.05 s. Therefore  $p_a \approx p_a^+$  during contraction. Similarly,  $p_v$  hardly changes, and  $p_{LV}/E_{LV}$  remains constant, thus

$$p_{LV} \approx E_{LV}(V^+ - V_0). \quad (6.7)$$

As  $E_{LV}$  rises rapidly during contraction, so also does  $p_{LV}$ , and the isovolumetric contraction phase continues until  $p_{LV}$  reaches  $p_a^+$ , the aortic valve opens, and the ejection phase begins. This will occur provided  $E_s(V^+ - V_0) > p_a^+$  (which is indeed the case).

Parameter	Value	Units
$V_{a0}$	0	ml
$V_{v0}$	4500	ml
$V_0$	17	ml
$R_a$	0.06	mm Hg s ml <sup>-1</sup>
$R_v$	0.016	mm Hg s ml <sup>-1</sup>
$R_c$	1.2	mm Hg s ml <sup>-1</sup>
$C_a$	1.5	ml mm Hg <sup>-1</sup>
$C_v$	50	ml mm Hg <sup>-1</sup>
$E_d$	0.06	mm Hg ml <sup>-1</sup>
$C_d$	16	ml mm Hg <sup>-1</sup>
$E_s$	3	mm Hg ml <sup>-1</sup>
$C_s$	0.3	ml mm Hg <sup>-1</sup>
$\Delta t_F$	0.3	s
$\Delta t_R$	0.6	s

Table 6.1: Values of the constants in (6.5). These are based on values used by Ursino (1998), but modified to account for the simpler description used here (i. e., with fewer compartments).

### Ejection (systole)

In the ejection phase, the aortic valve is open and  $p_{LV} > p_a > p_v$ ; outflow  $Q_+$  is positive, but inflow  $Q_- = 0$ . The governing equations are thus

$$\begin{aligned}
R_c C_a \dot{p}_a &= -(p_a - p_v) + \frac{R_c}{R_a} [p_{LV} - p_a], \\
R_c C_v \dot{p}_v &= (p_a - p_v), \\
R_c \left( \frac{p_{LV}}{E_{LV}} \right) &= -\frac{R_c}{R_a} [p_{LV} - p_a].
\end{aligned} \tag{6.8}$$

Estimated values of the parameters are, from table 6.1,  $R_c C_a \approx 1.8$  s,  $R_c C_v \approx 60$  s,  $R_c/R_a \approx 20$ ,  $R_c/E_s \approx 0.4$  s. Bearing in mind that the ejection phase lasts 0.3 s, (6.8)<sub>3</sub> implies that  $p_{LV} \approx p_a$  since  $R_c/R_a \gg 1$ ; addition of (6.8)<sub>1</sub> and (6.8)<sub>3</sub> then implies that

$$R_c C_a \dot{p}_a + R_c \left( \frac{\dot{p}_a}{E_{LV}} \right) \approx -p_a, \tag{6.9}$$

and this continues in the ejection phase until  $p_{LV} = p_a$  (exactly) again, which is when

$$\left( \frac{\dot{p}_{LV}}{E_{LV}} \right) \approx \left( \frac{\dot{p}_a}{E_{LV}} \right) = 0. \tag{6.10}$$

Because  $R_c C_v$  is large,  $p_v$  changes little during the ejection phase, and remains low.

(6.9) can be integrated explicitly to find  $p_a$ , given  $E_{LV}(t)$ . For simplicity, we focus on the case where the transition of  $E_{LV}$  from diastolic to systolic values is rapid, as is the transition back. From (6.7), the aortic valve opens when

$$E_{LV} \approx \frac{p_a}{(V^+ - V_0)}, \quad (6.11)$$

which is about 1.25 mm Hg ml<sup>-1</sup>. Supposing that the continuing rise of  $E_{LV}$  to its peak value of about  $E_s = 3$  mm Hg ml<sup>-1</sup> is rapid, it follows that during this rapid ascent phase,

$$R_c C_a p_a + \frac{R_c p_a}{E_{LV}} = R_c C_a p_a^+ + R_c (V^+ - V_0), \quad (6.12)$$

and thus  $p_a$  jumps to the value

$$\hat{p}_a = \frac{C_a p_a^+ + V^+ - V_0}{C_a + C_s}, \quad (6.13)$$

bearing in mind that  $C_s = 1/E_s$ . This is the peak arterial pressure in systole.

After  $E_{LV}$  reaches its peak, (6.9) still applies, but now with  $E_{LV} \approx E_s$ . Thus

$$p_a \approx \hat{p}_a \exp \left[ -\frac{t}{R_c (C_a + C_s)} \right] \quad (6.14)$$

(starting from  $t = 0$ ). The ejection phase finishes when (6.10) occurs, and this is essentially where  $E_{LV}$  starts to drop, at the end of the firing sequence, at  $t = \Delta t_F$ . The arterial pressure at the end of the ejection phase is thus

$$p_a \approx p_a^- = \hat{p}_a \exp \left[ -\frac{\Delta t_F}{R_c (C_a + C_s)} \right], \quad (6.15)$$

and this is the end systolic arterial pressure, and  $\Delta t_F$  is the firing time. At this point the left ventricular volume is

$$V_{LV} = V^- \approx V_0 + C_s p_a^-, \quad (6.16)$$

and thus the stroke volume  $\Delta V = V^+ - V^-$  is, using (6.13) and (6.15),

$$\Delta V = V^+ - V_0 - \left( \frac{C_s}{C_a + C_s} \right) [C_a p_a^+ + V^+ - V_0] \exp \left[ -\frac{\Delta t_F}{R_c (C_a + C_s)} \right]. \quad (6.17)$$

### Isovolumetric relaxation

At the end of the ejection phase, left ventricular elastance drops very rapidly, and the aortic valve closes. With both valves now closed,  $p_v < p_{LV} < p_a$ , inflow  $Q_-$  and outflow  $Q_+$  to and from the left ventricle are both zero, and left ventricular volume  $V_-$  remains constant. As for the contraction phase, both  $p_a$  and  $p_v$  are virtually constant, and left ventricular pressure is given by

$$p_{LV} \approx E_{LV} (V^- - V_0). \quad (6.18)$$

The mitral valve opens and filling commences when  $p_{LV} = p_v$ , and this when

$$E_{LV} \approx \frac{p_v}{(V^- - V_0)}, \quad (6.19)$$

and this is about 0.25 mm Hg ml<sup>-1</sup>.

### Filling (diastole)

During the filling phase, of about 0.5 s duration,  $p_{LV} < p_v < p_a$ ,  $Q_+ = 0$ , and the governing equations reduce to

$$\begin{aligned} R_c C_a \dot{p}_a &= -(p_a - p_v), \\ R_v C_v \dot{p}_v &= \frac{R_v}{R_c} (p_a - p_v) - (p_v - p_{LV}), \\ R_v \left( \frac{\dot{p}_{LV}}{E_{LV}} \right) &= p_v - p_{LV}. \end{aligned} \quad (6.20)$$

Relevant constants are  $R_c C_a \approx 1.8$  s,  $R_v C_v \approx 0.8$  s,  $R_v/R_c \approx 0.013$ , and  $R_v/E_d \approx 0.27$  s. As for the ejection phase,  $E_{LV}$  continues to fall rapidly to  $E_d$ , and during this short period

$$p_{LV} \approx E_{LV}(V^- - V_0), \quad (6.21)$$

while  $p_v$  and  $p_a$  hardly change. Thus the left ventricular pressure reaches the value

$$p_{LV} \approx E_d(V^- - V_0). \quad (6.22)$$

Following this, we have  $p_{LV} < p_v \ll p_a$ , so that  $p_a$  is approximately

$$p_a \approx p_a^- \exp \left[ -\frac{t}{R_c C_a} \right] \quad (6.23)$$

(measuring  $t$  from the beginning of filling. The second and third equations in (6.20) then give a pair of linear equations for  $p_v$  and  $p_{LV}$ .

From (6.23), the subsequent value of end diastolic arterial pressure is

$$p_a^{++} = p_a^- \exp \left[ -\frac{\Delta t_R}{R_c C_a} \right], \quad (6.24)$$

where  $\Delta t_R$  is the refractory period. This provides a map from the previous value  $p_a^+$  to  $p_a^{++}$ . Conjoining (6.13), (6.15) and (6.24), we have

$$p_a^{++} = \left( \frac{C_a p_a^+ + C_d p_v^+}{C_a + C_s} \right) \exp \left[ -\left\{ \frac{\Delta t_F}{R_c(C_a + C_s)} + \frac{\Delta t_R}{R_c C_a} \right\} \right], \quad (6.25)$$

where  $p_v^+$  is the end diastolic venous pressure (initially, where  $p_a = p_a^+$ ), and we have used the fact that end diastole occurs when  $p_{LV} = p_v$ , and that  $V^+ = V_0 + C_d p_v^+$ . If venous pressure is known, this provides a linear first order difference equation for  $p_a^+$ , which has a stable fixed point. From (6.17), stroke volume is given in terms of venous pressure by

$$\Delta V = C_d p_v^+ - \left( \frac{C_s}{C_a + C_s} \right) [C_a p_a^+ + C_d p_v^+] \exp \left[ -\frac{\Delta t_F}{R_c(C_a + C_s)} \right]. \quad (6.26)$$

## Venous pressure

Although venous pressure is small and does not vary much, it is important in the determination of arterial pressure and stroke volume through the formulae (6.25) and (6.26), because the diastolic compliance is so high. In fact,  $C_d p_v$  is of the same size as  $C_a p_a$ . Therefore we need to retrace our steps to calculate the corresponding map,  $p_v^+ \rightarrow p_v^{++}$ .

To begin with, the change of  $p_v$  in the contraction phase is very small, and is ignored. In the ejection phase, after  $E_{LV}$  reaches  $E_s$ ,  $p_v$  is given by (6.8)<sub>2</sub>, thus, approximately,

$$R_c C_v \dot{p}_v = p_a, \quad (6.27)$$

where  $p_a$  is given by (6.14), and thus

$$C_v(p_v - p_v^+) = (C_a + C_s)(\hat{p}_a - p_a). \quad (6.28)$$

At the end of systole,  $p_v = p_v^-$ , where from (6.15),

$$C_v(p_v^- - p_v^+) = (C_a + C_s)(\hat{p}_a - p_a^-). \quad (6.29)$$

In the relaxation phase,  $p_v$  is unchanged; then in the filling phase, (6.20)<sub>2</sub> implies (since  $p_a \gg p_v$ ) that  $p_v$  and  $p_{LV}$  satisfy

$$\begin{aligned} R_v C_v \dot{p}_v &\approx \frac{R_v p_a}{R_c} - (p_v - p_{LV}), \\ R_v C_d \dot{p}_{LV} &= p_v - p_{LV}. \end{aligned} \quad (6.30)$$

The  $p_v$  and  $p_{LV}$  terms are kept in the first of these equations because  $R_v/R_c \approx 0.013$ , and is small. The other two coefficients are  $R_v C_v \approx 0.8$  s, and  $R_v C_d \approx 0.27$  s, both comparable to the filling time of about 0.5 s. Adding the two, and using (6.23), we get

$$C_d \dot{p}_{LV} + C_v \dot{p}_v + C_a \dot{p}_a = 0 \quad (6.31)$$

(as we should!), and thus the values at beginning and end diastole are related by

$$(C_d + C_v)p_v^{++} + C_a p_a^{++} = C_v p_v^- + (C_a + C_s)p_a^-, \quad (6.32)$$

where we use (6.16) and (6.22) to determine the initial condition for  $p_{LV}$ , and use the fact that  $p_{LV} = p_v$  at end diastole. (6.32) provides the other part of the map we seek.

## Autonomic control

Exercise 6.8 shows that this map has a stable fixed point, which is rapidly approached. This stability is due purely to the mechanical pumping action of the heart, and indicates that in normal circumstances, the rhythmic pumping of the heart maintains homeostasis, or in other words keeps mean arterial pressure, venous pressure, and stroke volume at a constant level. This mechanical stability is called *autonomic control*. The action of the heart is also controlled by a number of other mechanisms, and we now discuss the principal features of the control exerted through the agency of the nervous system.

## 6.3 Nervous control of the heart

Cardiac output (blood flow as volume per unit time) is equal to the stroke volume times the heart rate; it is therefore the control of these quantities which controls the blood flow to the body tissues. Since blood is the agent of nutrient (oxygen) supply, it is evident that this needs to be tightly controlled. In the previous section we saw that the pumping mechanism of the heart is itself an agent for control of stroke volume and arterial pressure. Heart rate is controlled by the period of the oscillatory sino-atrial node firing, and this (as well as other parts of the circulatory system) is mainly controlled by the actions of the autonomic nervous system.

There are two parts to the nervous system which control cardiac output. These are the *sympathetic* and *parasympathetic* systems. Each in turn consists of *afferent* nerves (*ad + fero*, I carry to) taking messages to the brain, and *efferent* nerves (*ex + fero*, I carry from) taking messages from the brainstem or spinal cord. The afferent nerves transmit information from various kinds of receptors (*baroreceptors*, *chemoreceptors*); the efferent nerves innervate different parts of the system. One speaks of the tonic activity of these systems, meaning the rate of firing of the nerve fibres. Muscle tone refers to the same notion.

The sympathetic nervous system has two sub-systems, the  $\alpha$ -sympathetic system, which innervates the peripheral vasculature, and the  $\beta$ -sympathetic system, which innervates ventricular muscle. The sympathetic nerves act by releasing *noradrenaline*<sup>1</sup> and other neurotransmitters. In the peripheral circulation, these cause *vasoconstriction*, i. e., they constrict blood vessels, and thus increase peripheral resistance. This has the effect of decreasing cardiac output.

The release of noradrenaline and also adrenaline (together, these are called the *catecholamines*) by the  $\beta$ -sympathetic system in ventricular muscle has two effects. The *chronotropic* effect is that on the firing rate of the sino-atrial node. The effect of the release of catecholamines is to increase the inward calcium current to the *myocytes*, which in turn increases the firing frequency of the SA node. Thus the sympathetic system increases heart rate.

The other effect is the *inotropic* effect. Increasing sympathetic tone increases the contractility, or elastance, of ventricular muscle (by increasing the intracellular calcium transients). This then has the effect of increasing stroke volume.

In summary, the sympathetic system acts, via the release of catecholamines, to increase cardiac output. The system acts *slowly* over a time scale of the order of ten seconds, because this is the time scale for uptake of the catecholamines, and their effect on intercellular calcium.

In contrast, the parasympathetic system acts to decrease cardiac flow. It innervates the heart, particularly the sino-atrial node and the atrio-ventricular node, through the left and right *vagus* nerves. The vagus nerves act by releasing another transmitter, *acetylcholine*, which has an immediate effect on heart rate, causing it

---

<sup>1</sup>Noradrenaline is called *norepinephrine* in the American literature; similarly, *adrenaline* is called *epinephrine*.

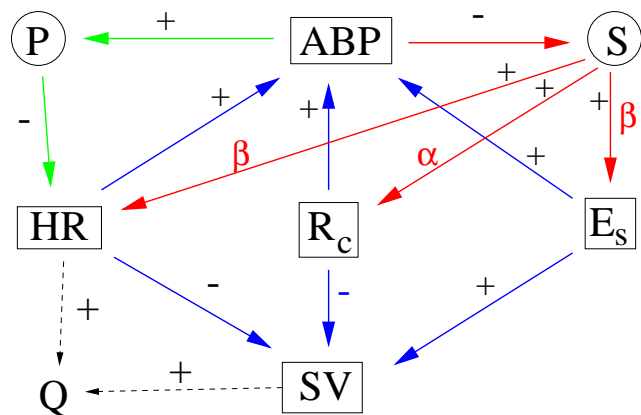

Figure 6.9: A schematic representation of the autonomic and nervous control systems of the heart.  $P$  and  $S$  represent parasympathetic and sympathetic systems,  $ABP$  is arterial blood pressure,  $HR$  is heart rate,  $R_c$  is peripheral resistance,  $E_s$  is systolic ventricular elastance,  $SV$  is stroke volume; heart rate and stroke volume combine to give cardiac output  $Q$ . Plus and minus signs indicate activating or inhibiting effect; blue arrows represent autonomic (pump action) control, red is the sympathetic system, green is the parasympathetic system.

to decrease (*bradycardia*) by altering the characteristics of the pacemaker firing oscillation; acetylcholine is an inhibitor for the pacemaking currents  $i_{Ca,L}$  and  $i_f$ . The parasympathetic system also innervates peripheral blood vessels, having a *vasodilative* effect, in contrast to the vasoconstrictive effect of the sympathetic system.

### Baroreceptor reflex

Sympathetic and parasympathetic tone is determined by signals transmitted along afferent nerves from various kinds of receptors. For the control of blood flow, the most important of these are the *baroreceptors*, located in the aortic arch in the chest, and in the *carotid sinus* in the neck. As their name indicates, baroreceptors respond to arterial pressure (via its effect of stretching the arterial wall), and the control effected through the feedback via the baroreceptors is called the *baroreflex*. Figure 6.9 shows the multiple feedback control loops which the above description embodies.

## 6.4 Oscillatory patterns

The heart rate oscillates on a variety of time scales, conventionally separated into three different magnitudes, each ascribed to a different control system.

The first of these is *respiratory sinus arrhythmia* (RSA), which is an oscillation of frequency 0.2–0.4 Hz, and is due to the coupling between respiration and heart rate. Specifically, heart rate increases on inspiration, and decreases during expiration. The simplest cause for this is that during inspiration, the intrathoracic pressure is low,

and this correspondingly causes the filling (venous) pressure to be low. From (6.25), this causes arterial pressure to drop, and hence the vagal feedback proposed in figure 6.9 leads to an immediate rise in heart rate.

The second oscillation, with a period of about ten seconds (frequency 0.1 Hz) goes by the name of *Mayer waves*; because the time scale is comparable to the response time of the sympathetic system, it is generally thought that Mayer waves are due to the sympathetic system, although (as we shall see) there are different ways in which their occurrence can be modelled.

The third frequency,  $\lesssim 0.1$  Hz, is associated with long term thermo-regulatory control, and is not discussed further.

## 6.5 Mathematical models of the baroreflex

The fundamental conceptual difficulty which arises in modelling the control of heart rate is that the basic pumping mechanism itself is not smooth, because of valve opening and closure. As we have seen above, this naturally leads to a pump action model which gives a map: in our case, of the values of end diastolic arterial and venous pressures from one cycle to the next. Vagal control fits naturally into this scheme, because the response is virtually instantaneous, and this leads to a beat-to-beat model, exemplified by the De Boer model which is discussed below in section 6.5.2. Such a model would hope to explain RSA, for example.

It is less easy to put sympathetic control into a beat-to-beat model, because it is effected continuously by the uptake of catecholamines released at nerve endings. The best one can do is to represent its effect by a distributed delayed effect over a number of heart beats, and this is what the De Boer model does.

The natural alternative for longer term sympathetic control is to suppose that the arterial and venous blood pressures and other quantities of the system vary slowly under the influence of the slowly acting sympathetic system, so that their evolution can be modelled by differential equations, and this is what the Ottesen model, described next, does. Ideally, the resulting continuous model is derived from a more realistic beat-to-beat model by a formal process of averaging, but in practice this procedure is short circuited, and one writes down the continuous model directly from first principles, on the basis that pump action is continuous. A similar principle is followed in modelling respiratory control (see chapter 7).

### 6.5.1 Ottesen model

This model is described by Ottesen (1997). There are three variables, the (averaged) arterial and venous pressures  $p_a$  and  $p_v$ , and the heart rate  $H$ . Control is effected by sympathetic and parasympathetic tones (i.e., firing frequencies), and these are assumed to be given by

$$T_s = g(p_a^r), \quad T_p = 1 - g(p_a), \quad (6.33)$$



where  $p_a^\tau = p_a(t - \tau)$  is the arterial pressure a time  $\tau$  in the past. The choice of the controlling function  $g$  is the sigmoidal Hill function given by

$$g(p) = \frac{1}{1 + (p/p_0)^n}, \quad (6.34)$$

and the choice of the Hill exponent  $n$  is quite high (for example  $n = 7$ ) in order that control be effected sharply.

The representation of sympathetic control in terms of delayed arterial pressure is a simple surrogate to represent the slow response to release of catecholamines by the sympathetic nerves. A more realistic model would have a distributed delay, and ultimately one would want to incorporate details of the sino-atrial node cell firing oscillation in terms of intracellular calcium, potassium and sodium concentrations.

The essence of the model lies in the way in which  $H$  responds to  $T_s$  and  $T_p$ . Ottesen chooses  $\dot{H} = F(T_s, T_p)$ , and specifically (by way of example)

$$\dot{H} = \frac{\alpha_H T_s}{1 + \gamma T_p} - \beta_H T_p, \quad (6.35)$$

which represents the effect of sympathetic and parasympathetic tone on rate of change of heart rate, and also includes the inhibiting effect of the vagal response on the sympathetic response, through the coefficient  $\gamma$ .

There is an odd feature of this choice. In reality, if one cuts (or deactivates) both the sympathetic and parasympathetic systems in humans, then the heart rate settles at a steady hundred beats per minute. In the model, this corresponds to putting both  $T_s$  and  $T_p$  to zero, but we see that there is then no preferred heart rate, and it is neutrally stable. This is because there is no damping term in the equation for  $H$ , which is something in a real physical system that one might expect. It is suggestive of structural instability in the model and, as we shall see, it can lead to unphysical behaviour.

We therefore propose a modified version of the Ottesen model, which is

$$\dot{H} = \delta_H (H_0 - H) + \frac{\alpha_H T_s}{1 + \gamma T_p} - \beta_H T_p, \quad (6.36)$$

where  $H_0$  denotes the natural resting heart rate in the absence of nervous tone. A motivation for this choice can be found by consideration of what actually determines heart rate. This was discussed in chapter 5. The heart rate is the inverse of the period  $P$  of a limit cycle oscillation involving intracellular concentrations of calcium, potassium and sodium in the sino-atrial node cells. The essence of any such model is captured by the Landau-Ginzburg equation

$$\frac{dz}{dt} = az - b|z|^2 z, \quad (6.37)$$

where  $a$  and  $b$  are complex, and  $a_R (= \text{Re } a) > 0$ ,  $b_R > 0$ .<sup>2</sup> If we define the period of the evolving oscillation as the interval  $P$  between values of zero phase ( $\arg z = 0$

---

<sup>2</sup>This equation universally describes the amplitude of periodic solutions in the vicinity of a Hopf bifurcation.

mod  $2\pi$ ), then it is straightforward to show that  $P = P(A)$ , where  $A$  is the amplitude of  $z$ , and thus that  $H = 1/P$  satisfies an evolution equation of the form

$$\dot{H} = r(H) [H_0 - H]. \quad (6.38)$$

This provides the motivation for the form of (6.36) in the absence of nervous tone.

The model for heart rate is supplemented by the two blood pressure equations

$$\begin{aligned} C_a \dot{p}_a &= -\frac{p_a - p_v}{R_c} + H \Delta V, \\ C_v \dot{p}_v &= \frac{p_a - p_v}{R_c} - \frac{p_v}{R_v}, \end{aligned} \quad (6.39)$$

which can be compared directly to the first two equations in (6.5); the compliances  $C_k$  and resistances  $R_k$  carry the same meaning as before, as does the stroke volume  $\Delta V$ .

The first equation is the continuous version of conservation of arterial blood volume, since  $Q = H \Delta V$  is the cardiac output. The second equation represents conservation of venous blood volume, if ventricular (or, more properly, atrial) pressure is ignored in (6.20) during filling.

The model can be simplified in much the same way as the pump action model, by observing that a balance of terms on the right hand side of (6.39) suggests  $p_a - p_v \sim R_c Q$  and  $p_v \sim R_v Q$ , and thus that  $p_v/p_a \sim R_v/R_c \sim 10^{-2}$ , if we use the values for resistance in table 6.1. (Since  $1/R_v$  is an average conductance over the heart beat, the value we use for it in the continuous model should be reduced, and thus the value for  $R_v$  should be increased in (6.39); a mild increase is still consistent with the observation that  $p_v \ll p_a$ . In fact, Ottesen use a value four times higher for  $R_v$ , but a similar value for  $R_c$ .)

Allowing that  $p_v \ll p_a$  enables (6.39)<sub>1</sub> to be approximated as

$$R_c C_a \dot{p}_a = -p_a + R_c \Delta V H. \quad (6.40)$$

We note from table 6.1 that we have typical values  $R_c C_a \sim 1.8$  s, and for cardiac output  $Q = 5 \text{ l min}^{-1} \sim 80 \text{ ml s}^{-1}$ ,  $R_c Q \sim 100 \text{ mm Hg}$ .

There are three time constants in (6.36):  $\delta_H$ ,  $\alpha_H/H_0$  and  $\beta_H/H_0$ . We choose  $H_0 = 100 \text{ min}^{-1} = 1.7 \text{ s}^{-1}$ , as the resting heart rate in the absence of nervous control. The choice of  $\delta_H$  relies on a detailed model of the sino-atrial cell firing oscillation. In the absence of any other information, the natural choice for  $\delta_H$  is the time constant of the oscillator, which is thus simply  $\delta_H = H_0$ . Ottesen's preferred values for  $\alpha_H$  and  $\beta_H$  are  $\alpha_H = 0.84 \text{ s}^{-2}$  and  $\beta_H = 1.17 \text{ s}^{-2}$ , and we will use these for illustration. We then have

$$\alpha = \frac{\alpha_H}{H_0^2} \sim 0.3, \quad \beta = \frac{\beta_H}{H_0^2} \sim 0.4, \quad \delta = \frac{\delta}{H_0} \sim 1. \quad (6.41)$$

He also chooses to put  $\gamma = 0$ , and we will do this also. In this simple model, the stroke volume is taken as constant. More generally, we would take  $\Delta V$  as a function of arterial pressure.

We now non-dimensionalise the approximate (i. e., neglecting  $p_v$ ) model by writing

$$H = H_0 h, \quad p_a = p_0 p, \quad t \sim \tau \quad (6.42)$$

( $p_0$  is defined in (6.34)); the corresponding dimensionless model is then

$$\begin{aligned} \varepsilon_p \dot{p} &= -p + \mu h, \\ \varepsilon_H \dot{h} &= \delta(1 - h) + \frac{\alpha g(p_1)}{1 + \gamma\{1 - g(p)\}} - \beta\{1 - g(p)\}, \end{aligned} \quad (6.43)$$

where now

$$g(p) = \frac{1}{1 + p^n}, \quad (6.44)$$

and the notation  $p_1$  denotes the delayed arterial pressure  $p(t - 1)$ . The additional parameters in (6.43) are given by

$$\varepsilon_p = \frac{R_c C_a}{\tau}, \quad \varepsilon_H = \frac{1}{H_0 \tau}, \quad \mu = \frac{R_c \Delta V H_0}{p_0}, \quad (6.45)$$

and we can take typical values  $\varepsilon_p \sim 0.18$ ,  $\varepsilon_H \sim 0.06$ ,  $\mu \sim 1$  (the latter because we can undoubtedly assume that the nervous controls are effective at a typical value of arterial pressure).

We can now take advantage of the fact that both  $\varepsilon_p$  and particularly  $\varepsilon_H$  are relatively small. Since  $\varepsilon_H < \varepsilon_p$ , we suggest first that  $h$  rapidly approaches a quasi-equilibrium state. If we take  $\gamma = 0$  and  $\delta = 1$ , then this quasi-steady state is

$$h \approx 1 - \alpha g(p_1) + \beta\{1 - g(p)\}, \quad (6.46)$$

and substituting this into (6.43)<sub>1</sub> yields the delay recruitment type equation

$$\varepsilon \dot{p} = 1 - p + \beta\{1 - g(p)\} - \alpha g(p_1), \quad (6.47)$$

where we have written  $\varepsilon_p = \varepsilon$ .

Steady state solutions satisfy

$$g(p) = c + \frac{1 - p}{\alpha + \beta}, \quad (6.48)$$

where  $c = \beta/(\alpha + \beta)$ . There can be up to three steady states of this equation, depending on the values of the parameters. This is most easily seen when  $\alpha = \beta$ , for then  $c = 1/2$ , and  $p = 1$  is always a solution. As  $\alpha + \beta$  decreases from  $\infty$ , another root at  $p \approx \alpha + \beta$  decreases and intersects  $p = 1/2$  in a transcritical bifurcation at  $\alpha + \beta = 4/n$ ; below this there is a saddle node bifurcation as the root turns round and increases until it crosses  $p = 0$  at  $\alpha + \beta = 2$ . The saddle node and transcritical bifurcations would merge in a symmetrical pitchfork bifurcation if  $g(p)$  were symmetrical about  $p = 1$ . When  $\alpha \neq \beta$ , the bifurcation is broken, revealing the typical result of imperfection shown in figure 6.10.

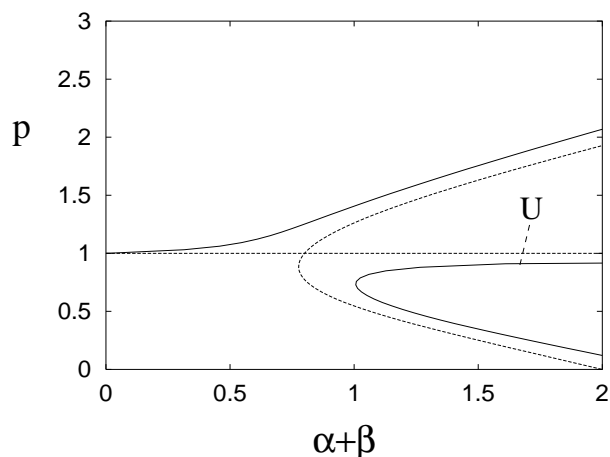

Figure 6.10: Steady state solutions  $p$  of (6.47) for  $c = 0.56$  ( $\alpha/\beta \approx 0.79$ ) (solid curves) and  $c = 0.5$  ( $\alpha = \beta$ ) (dashed curves) as functions of  $\alpha + \beta$ .

Stability of the steady states is ascertained by linearising the model about them. Solutions of the linear equations proportional to  $\exp(\sigma t)$  exist provided

$$\sigma = -B - Ge^{-\sigma}, \quad (6.49)$$

where

$$B = \frac{1 + \beta g'}{\varepsilon}, \quad G = \frac{\alpha g'}{\varepsilon}. \quad (6.50)$$

Instability then occurs if  $\text{Re } \sigma > 0$ , and the instability is oscillatory if  $\text{Im } \sigma \neq 0$ .

This is an equation which we will meet again and again in the following chapters, and the results we need are delineated in question 8.3 of chapter 8. (6.49) is a transcendental equation, which has an infinite number of complex roots, no more than two of which are real. The roots accumulate at the essential singularity at  $\sigma = -\infty$ , and thus the set of  $\text{Re } \sigma$  is bounded above. There is an instability criterion which determines when *all* the roots  $\sigma$  have negative real part, and this is indicated in figure 6.11.

Consideration of the intersections of  $(\alpha + \beta)g(p)$  with  $1 - p + \beta$  show that when there are three steady states,  $B + G < 0$  for the intermediate one, while  $B + G > 0$  for the other two. Therefore the intermediate steady state is always unstable, with  $\sigma > 0$ ; this corresponds to our expectation in ordinary differential equations, and is indicated on figure 6.10.

The other two equilibria have  $B + G > 0$ , and if  $|G|$  is large enough, oscillations will occur. Instability is thus promoted by large  $\alpha$ , small  $\varepsilon$  or large  $|g'|$ , and a sufficient condition for instability is  $|G| > 1$ . Since a Hopf periodic orbit bifurcates from  $G = \gamma_1(B)$ , we expect that the result of this instability will be periodic motion at a frequency associated with the delay time. The dimensionless period of the bifurcating periodic solution is  $P \rightarrow 2$  as  $B \rightarrow \infty$ ,  $P \rightarrow 4$  as  $B \rightarrow 0$ , and  $P \rightarrow \infty$  as  $B \rightarrow -1$ ,

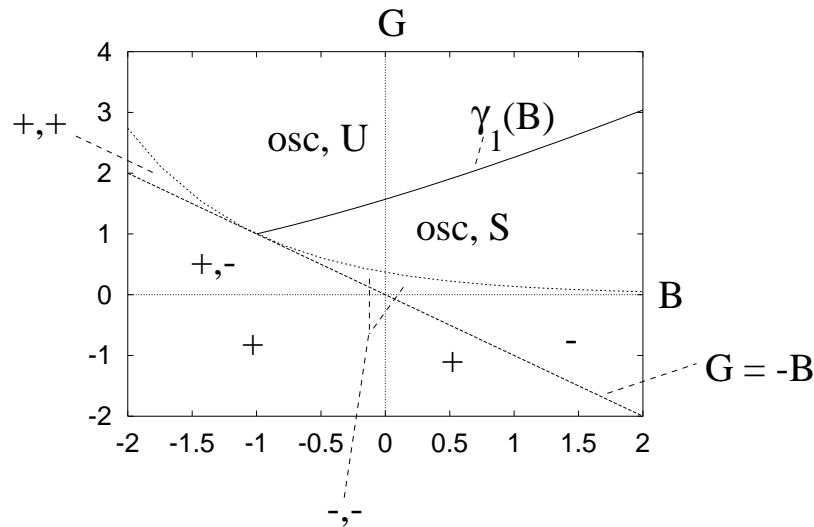

Figure 6.11: Stability map for the solutions of (6.49). The curves demarcate the behaviours of the two roots involved in transition to instability. ‘osc’ means complex conjugate, and ‘U’ is unstable, ‘S’ is stable; ‘+’ and ‘-’ refer to the signs of real roots; where only one sign is indicated, the other root has disappeared by tending to infinity. The diagram indicates that stability occurs only if  $G$  lies within the sector bounded by the two curves  $G = -B$  and  $G = \gamma_1(B)$ .

the behaviour being monotonic along the bifurcation curve. The dimensional period is simply  $P\tau$ . This suggests that if this model is to be used to predict 10 second Mayer waves, then the delay needs to be chosen a good deal lower than 10 seconds. This has the effect of increasing  $\varepsilon$  and thus decreasing our estimate of the size of  $|G|$ .

### The limit $\delta \rightarrow 0$

It is evident from (6.43) that if  $\delta \neq 1$ , one simply replaces  $\varepsilon_H$ ,  $\alpha$  and  $\beta$  by  $\varepsilon_H/\delta$ ,  $\alpha/\delta$  and  $\beta/\delta$ . As long as  $\varepsilon_H \ll \alpha, \beta$ ,  $h$  still rapidly approaches equilibrium, and the subsequent discussion above of steady states and stability is unaffected, except that one uses  $\alpha/\delta$  and  $\beta/\delta$  in (6.48) and (6.50). Thus as  $\delta \rightarrow 0$ , the only remaining finite steady state is the always unstable intermediate state. It is in this sense that Ottesen’s choice of  $\delta = 0$  is inadvisable. (The results here cannot be directly compared to those of Ottesen, because of the interchange of the order of the limits  $\delta \rightarrow 0$ ,  $\varepsilon_H \rightarrow 0$ .)

### 6.5.2 De Boer model

The model of heart rate due to De Boer, Karemaker and Strackee (1987) is a beat-to-beat model, which relates successive values of peak systolic pressure  $P$  and end diastolic pressure  $D$ . In terms of the notation we used earlier,  $p_a^+ = D$ ,  $\hat{p}_a = S$ . While the Ottesen model focuses on the control of heart rate by the nervous systems, the De Boer model also allows for its effect on peripheral resistance  $R_c$ . This is done through

an equation for the time constant  $T$ , which in our notation is given by  $T = C_a R_c$ . Finally heart rate is included by having an equation for the beat-to-beat interval  $I$ , conventionally measured as the RR interval (see figure 6.8)

In the model, the effect of peak systolic arterial pressure on baroreceptor response is represented by a function  $F(S)$  with units of pressure, which is taken as a sigmoidal function increasing from about 90 mm Hg to about 150 mm Hg as  $S$  increases through normal values of 120 mm Hg. Thus  $F$  is essentially a shifted version of the Hill function,  $F = A - Bg$ , and in some way it represents the firing rate of the efferent nerves. In terms of this firing rate, the RR interval is taken to be

$$I_n = I^* + \sum_{k \geq 0} a_k F_{n-k}, \quad (6.51)$$

where  $n$  indexes the sequence of heart beats. This is an analogue of (6.36). Both sympathetic and parasympathetic systems decrease heart rate (thus increase RR interval) on increasing arterial blood pressure, and both effects are indicated by (6.51) if the coefficients  $a_k$  are positive. The index  $k = 0$  then represents the vagal effect, and  $k > 0$  represents the delayed sympathetic response. The continuum limit of (6.51) would be

$$I(t) = I^* + A_V p_a(t) + \int_0^\infty A(s) f[p_a(t-s)] ds, \quad (6.52)$$

with some suitable redefinition of  $a_k$  and  $F$ , and this would be consistent with (6.43)<sub>2</sub> if there were a distributed delay in the Ottesen model. De Boer *et al.* choose values of  $a_k$  for  $k > 0$  distributed round a maximum at  $k = 4$ . The corresponding discrete delay in the Ottesen model would then be  $4/H$ , about 3.5 seconds. The value  $a_0$  is manifested as the vagal coefficient  $A_V$ .

Consulting figure 6.9, we see that the blood pressure has an inhibitory effect on the peripheral resistance due to the sympathetic system, and thus on the time constant  $T = C_a R_c$ . In the De Boer model, this is effected through the equation

$$T_n = T^* - \sum_{k > 0} b_k F_{n-k}, \quad (6.53)$$

and the  $b_k$ 's are taken to be a multiple (twice) of the  $a_k$ 's. There is no corresponding effect in the Ottesen model, though it would simply be included by suitable functional dependence of  $R_c$  in (6.39). The continuum limit of (6.53) would be

$$T(t) = T^* - \int_0^\infty B(s) f[p_a(t-s)] ds. \quad (6.54)$$

The model is completed by two equations for  $S$  and  $D$  which describe the pump action of the heart. The equations (6.39) play the same rôle in the Ottesen model, although the De Boer model omits reference to the venous or filling pressure. The first equation is the *Windkessel* model,

$$D_n = c S_{n-1} \exp \left[ -\frac{I_{n-1}}{T_{n-1}} \right]. \quad (6.55)$$

This equation comes directly from consideration of pump action, and is written, in the notation of section 6.2, as

$$p_a^{++} = c\hat{p}_a \exp \left[ -\frac{\Delta t_F + \Delta t_R}{R_c C_a} \right], \quad (6.56)$$

whereas from (6.15) and (6.24) we have, in fact,

$$p_a^{++} = \hat{p}_a \exp \left[ -\frac{\Delta t_F}{R_c(C_a + C_s)} - \frac{\Delta t_R}{R_c C_a} \right]. \quad (6.57)$$

The Windkessel model thus follows from our simple pump model providing  $C_s \ll C_a$ , which is not unreasonable according to table 6.1.

The second equation relates pulse pressure  $S - D$  to the length of the preceding RR interval, thus

$$S_n = D_n + \gamma I_{n-1} + P^*. \quad (6.58)$$

In our notation this is

$$\hat{p}_a = p_a^+ + \gamma(\Delta t_F + \Delta t_R) + P^*, \quad (6.59)$$

whereas (6.13) implies

$$\hat{p}_a = \frac{C_a p_a^+ + C_d p_v^+}{C_a + C_s}. \quad (6.60)$$

De Boer *et al.*'s motivation for (6.58) is that a longer filling interval leads to a more powerful contraction (thus an increased stroke volume) via Starling's law, and also via the contractility of the myocardium, which also increases following a longer filling interval. This discussion muddies the waters, since figure 6.9 suggests no direct connection between heart rate and ventricular elastance. Starling's law is indeed manifested by (6.60), insofar as the increase of  $\hat{p}_a$  with  $p_v^+$  leads to an increase in stroke volume (cf. (6.17)) and thus cardiac output, but the effect on ventricular elastance is relatively small, and more importantly is effected through the slow sympathetic system. In fact, (6.60) suggests that the De Boer model should properly include a beat-to-beat model of the venous pressure, which would follow from (6.32).

For suitable choices of the model parameters, De Boer *et al.* found that model simulations produced Mayer waves, and also respiratory sinus arrhythmia, when respiratory forcing was included by allowing  $P^*$  in (6.58) to vary in time with the respiratory frequency (the assumption being that respiration affects the filling pressure via its effect on the intra-thoracic pressure).

## 6.6 Notes and references

### Exercises

- 6.1 Describe the sequence of events which occurs in the human circulatory system during a single heart beat. Your description should include a schematic illustration of the circulatory system, how filling and emptying of the atria and

ventricles is effected by valve opening and closing, and how this affects the pressure and volume of the left ventricle.

- 6.2 What is meant by *stroke volume* and *heart rate*? How does the cardiac output depend on these?

A simple model of the circulation consists of a (left) ventricle (with mitral and aortic valves), arteries, veins and capillaries. Show that a simple compartment model for this system which describes the volumes of the arteries, veins and ventricle can be written in the form

$$\dot{V}_a = Q_+ - Q_c,$$

$$\dot{V}_v = Q_c - Q_-,$$

$$\dot{V}_{LV} = Q_- - Q_+,$$

and describe the meaning of the variables. What assumption is made about the capillary volume in writing these equations?

- 6.3 What is meant by *compliance*, *elastance* and *resistance* of blood vessels?

In the model of question 6.2, let  $p_a$ ,  $p_v$  and  $p_{LV}$  denote the pressures in arteries, veins and left ventricle, respectively. Denoting resistances and compliances of compartment  $k$  by  $R_k$  and  $C_k$ , respectively, write down expressions for  $Q_{jk}$ , where  $Q_{jk}$  is the blood flow from compartment  $j$  to compartment  $k$ , and hence derive a model consisting of three ordinary differential equations for the three compartment pressures.

Illustrate on a diagram of  $p_k$  versus  $V_{LV}$  how you expect the pressures to oscillate during a heart beat.

- 6.4 What is meant by *systole* and *diastole*?

Write down a model of the circulation which describes the volumes of separate compartments representing left atrium, left ventricle, arteries, capillaries and veins. Assume that three valves (e. g., pulmonary, mitral and aortic) separate the veins, left atrium, left ventricle and arteries. By assuming compliances and resistances  $C_k$  and  $R_k$  for compartment  $k$ , write the model in the form of differential equations for the pressures in each compartment.

- 6.5 What are the four valves of the heart, and what is their purpose?

The blood flow rates to and from the heart (i.e., to the right atrium and from the left ventricle) are taken to be equal, and denoted by  $Q(t)$ . Write down a four compartment model of the pulmonary circulation for the volumes of left and right atria and ventricles, assuming that the pulmonary flow provides resistance but has no volume. Using appropriate compliances and resistances, derive equations for the pressure of each chamber of the heart.



6.6 A one chamber model of the circulation having a left ventricle, arteries, veins and peripheral resistance is written in the form

$$R_c C_a \dot{p}_a = -(p_a - p_v) + \frac{R_c}{R_a} [p_{LV} - p_a]_+,$$

$$R_c C_v \dot{p}_v = (p_a - p_v) + \frac{R_c}{R_v} [p_v - p_{LV}]_+,$$

$$\left( \frac{\dot{p}_{LV}}{E_{LV}} \right) = \frac{[p_v - p_{LV}]_+}{R_v} - \frac{[p_{LV} - p_a]_+}{R_a}.$$

Describe the meaning of the terms, and explain briefly how the model is derived.

The effect of cardiac contraction on the ventricle elastance is modelled by assuming that  $E_{LV}$  jumps rapidly between a low diastolic value  $E_d$  and a high systolic value  $E_s$ . The systolic value is held for a time interval  $\Delta t_F \approx 0.3$  s, and the diastolic value is held for a time interval  $\Delta t_R \approx 0.5$  s.

Suppose that the end diastolic arterial pressure is  $p_a^+$  and that the end diastolic ventricular volume is  $V_+$  (so that  $p_{LV} \ll p_a^+$ ). Suppose also that  $R_c C_a = 1.8$  s,  $R_c C_v = 60$  s,  $R_c C_s = 0.4$  s,  $R_c C_d = 19.2$  s,  $R_c/R_v = 75$ , and  $R_c/R_a = 20$ .

Show that during systole, where  $E_{LV}$  jumps rapidly from  $E_d$  to  $E_s$  and is maintained there for an interval of duration  $\Delta t_F$ , there is a period of isovolumetric contraction until  $p_{LV}$  reaches  $p_a^+$  and the aortic valve opens, followed by a period of ejection, during which  $p_{LV} \approx p_a$ , and  $p_a$  rapidly jumps to the peak systolic value

$$p_a \approx \frac{C_a p_a^+ + V^+ - V_0}{C_a + C_s},$$

( $V_0$  is the resting ventricular volume at zero pressure), after which

$$R_c C_a \dot{p}_a + R_c \left( \frac{\dot{p}_a}{E_{LV}} \right) \approx -p_a.$$

(Assume that  $p_v \ll p_a$ .)

Deduce that the end systolic arterial pressure is

$$p_a = p_a^- \approx \frac{C_a p_a^+ + V^+ - V_0}{C_a + C_s} \exp \left[ \frac{-\Delta t_F}{R_c (C_a + C_s)} \right],$$

and thus that the stroke volume is

$$\Delta V \approx V^+ - V_0 - \left( \frac{C_s}{C_a + C_s} \right) [C_a p_a^+ + V^+ - V_0] \exp \left[ \frac{-\Delta t_F}{R_c (C_a + C_s)} \right].$$

6.7 In the model of question 6.6, suppose that the end systolic ventricular volume is  $V^-$ . Show that systole is followed by a rapid isovolumetric relaxation period,

and then a filling period of duration  $\Delta t_R$ , in which firstly  $p_{LV} \rightarrow E_d(V^- - V_0)$  rapidly, and then  $p_a$  decays exponentially. (Assume  $p_v, p_{LV} \ll p_a$ , explaining why.) Deduce that if  $p_a^-$  is the end systolic arterial pressure, then the end diastolic arterial pressure is

$$p_a^{++} \approx p_a^- \exp \left[ \frac{-\Delta t_R}{R_c C_a} \right].$$

If the venous pressure is  $p_v$  and is taken to be constant, show that  $V_+ - V_0 \approx C_d p_v$ , and deduce (using also the results of question 6.1) that

$$p_a^{++} \approx A p_a^+ + B,$$

and give definitions for  $A$  and  $B$ . Use the numerical values  $V_0 = 17$  ml,  $R_a = 0.06$  mmHg s ml<sup>-1</sup>,  $R_v = 0.016$  mmHg s ml<sup>-1</sup>,  $R_c = 1.2$  mmHg s ml<sup>-1</sup>,  $C_a = 1.5$  ml mmHg<sup>-1</sup>,  $C_v = 50$  ml mmHg<sup>-1</sup>,  $C_d = 16$  ml mmHg<sup>-1</sup>,  $C_s = 0.34$  ml mmHg<sup>-1</sup>,  $p_v \approx 7$  mmHg, to find values of  $A$  and  $B$ ; hence determine the behaviour of successive values of  $p_a^+$ .

6.8 Use the equations (6.15), (6.24), (6.25), (6.29) and (6.32) to write the arterial pressure map in the form

$$A \mathbf{w}_{n+1} = B \mathbf{w}_n,$$

where  $A$  and  $B$  are constant matrices, and

$$\mathbf{w}_n = \begin{pmatrix} C_a p_a^+ \\ (C_v + C_d) p_v^+ \end{pmatrix}, \quad \mathbf{w}_{n+1} = \begin{pmatrix} C_a p_a^{++} \\ (C_v + C_d) p_v^{++} \end{pmatrix},$$

and show that  $w_1 + w_2$  is approximately constant (use the values in table 6.1). What does this signify?

By using this to eliminate  $p_v^+$  from (6.25), show that the map  $p_a^+ \rightarrow p_a^{++}$  has a unique stable fixed point. Show that the fixed point is in fact very stable, and comment on how the values of the parameters ensure that this is so.

6.9 Suppose that  $z \in \mathbf{C}$  satisfies

$$\frac{dz}{dt} = az - b|z|^2 z,$$

where  $a = a_R + ia_I$  and  $b = b_R + ib_I$ , and  $a_R, b_R > 0$ . Write down differential equations for the amplitude  $A > 0$  and phase  $\theta$  of  $z = Ae^{i\theta}$ . Hence draw the phase trajectories for the equation in the complex  $z$  plane. Show that there is a limit cycle with amplitude  $A_0 = (a_R/b_R)^{1/2}$ , and find its period.

Define the recurrence period  $P(A)$  to be the time interval over a trajectory which starts at amplitude  $A$  with  $\theta = 0$  and finishes at  $\theta = 2\pi$ . Suppose that  $A = A^+$  on this trajectory when  $\theta = 2\pi$ . Show that

$$P(A) = I(A^+) - I(A),$$

where  $I$  is given by an integral which you should find. Show also that

$$2\pi = K(A^+) - K(A),$$

where  $K$  is another integral which you should find. Plot the functions  $I(A)$  and  $K(A)$  [*beware! You need to be careful how you choose the lower limits in the integrals.*]

Hence write an explicit expression for  $P(A)$  in terms of the functions  $I$ ,  $K$  and  $K^{-1}$ ; plot  $P(A)$ .

If the inverse function is denoted  $A = J(P)$  and  $H = 1/P$ ,  $H_0 = 1/P(A_0)$ , deduce that

$$\dot{H} = r(H)(H_0 - H),$$

where

$$r = \frac{b_R H^2 J(1/H)[J(1/H) + J(1/H_0)]}{J'(1/H)} \left( \frac{J(1/H) - J(1/H_0)}{H_0 - H} \right).$$

What is the value of  $r(H_0)$ ? Is  $r > 0$  for  $H \neq H_0$ ?

- 6.10 Write the equations (6.36) and (6.39) in a suitable dimensionless form, and hence show that the venous pressure equation approximately uncouples from the other two equations providing  $R_v \ll R_c$ .
- 6.11 Suppose that  $\mu = 1$ ,  $\gamma = 0$ , and that  $\varepsilon_H \sim \delta \ll 1$  in (6.43). Show that a regularising approximation implies that  $p$  satisfies the difference equation

$$p \approx f(p_1),$$

where

$$f(p) = g^{-1} \left[ 1 - \frac{\alpha}{\beta} g(p) \right],$$

and show that this difference equation has a unique steady state.

For a difference equation of the form  $L(p_{n+1}) = R(p_n)$ , show how cobwebbing can be used to trace trajectories as they move between the graphs of  $L$  and  $R$ .

Show that the derivative of the inverse function  $L^{-1}(\xi)$  is

$$(L^{-1})'(\xi) = \frac{1}{L'[L^{-1}(\xi)]}.$$

Deduce that a fixed point of the map  $\xi \rightarrow \xi'$  defined by  $L(\xi') = R(\xi)$  is stable iff  $|L'/R'| < 1$  at the fixed point.

Hence show that the fixed point of the approximating map for  $p_n$  is unstable if  $\alpha > \beta$ . Use cobwebbing to suggest that a stable period two cycle emerges in this case.

- \* Show how singular perturbation methods can be used to construct approximate Mayer waves (period  $2\tau$ ) in this case.

6.12 Use graphical methods to explain why the solutions of (6.33) have the form shown in figure 6.10.

# Chapter 7

## Respiration

### 7.1 The respiratory system

The body consists of a huge collection of cells, and these cells, just like us, need to be fed and have their waste products removed. The principal nutrient of cells is oxygen, and the principal excretion is carbon dioxide. It is the primary function of the blood to carry oxygen to all the cells of our body, and to remove carbon dioxide from them. The cardiovascular system does this by passing blood through very small capillaries which exchange blood gases through the capillary walls with the surrounding tissue. Arterial blood from the heart is red and oxygen rich, while venous blood returning to the heart is blue and oxygen poor. It is the function of the respiratory system to enable the venous blood passing from the heart to the pulmonary circulation to discharge some of its load of carbon dioxide, and to pick up a load of fresh oxygen from the lungs. The way in which this is effected is similar to the way in which the cardiovascular system interacts with the tissues.

The lungs form a branched system, with some twenty-three generations of branches from the inlet windpipe or *trachea* to the alveoli. They are not therefore simply bags, but very finely detailed structures as shown in figure 7.1. The reason for this is that the alveolar sacs have a huge surface area of some  $70 \text{ m}^2$ , and it is across this surface that transfer of  $\text{O}_2$  and  $\text{CO}_2$  takes place. The alveoli are perfused by the capillaries of the pulmonary circulation, and the contact is so extensive that blood passing the lungs reaches gas concentration equilibrium before returning to the left atrium of the heart. For example, oxygen partial pressure in the alveoli is about 100 mm Hg (millimetres of mercury: 760 is atmospheric pressure, 150 is atmospheric oxygen partial pressure<sup>1</sup>), whereas it is about 40 mm Hg in the incoming venous blood. Nevertheless, it reaches 100 mm Hg before leaving the lungs. Similarly, alveolar  $\text{CO}_2$  partial pressure is some 40 mm Hg, whereas incoming venous blood has a  $\text{CO}_2$  partial pressure of about 45 mm Hg, but the arterial blood which is ejected from the heart has had its  $\text{CO}_2$  load

---

<sup>1</sup>More precisely, the partial pressure of atmospheric oxygen in dry air at sea level is 159 mm Hg, but on inhalation it becomes warm and wet, with a consequent partial pressure of 149 mm Hg. More on this later.

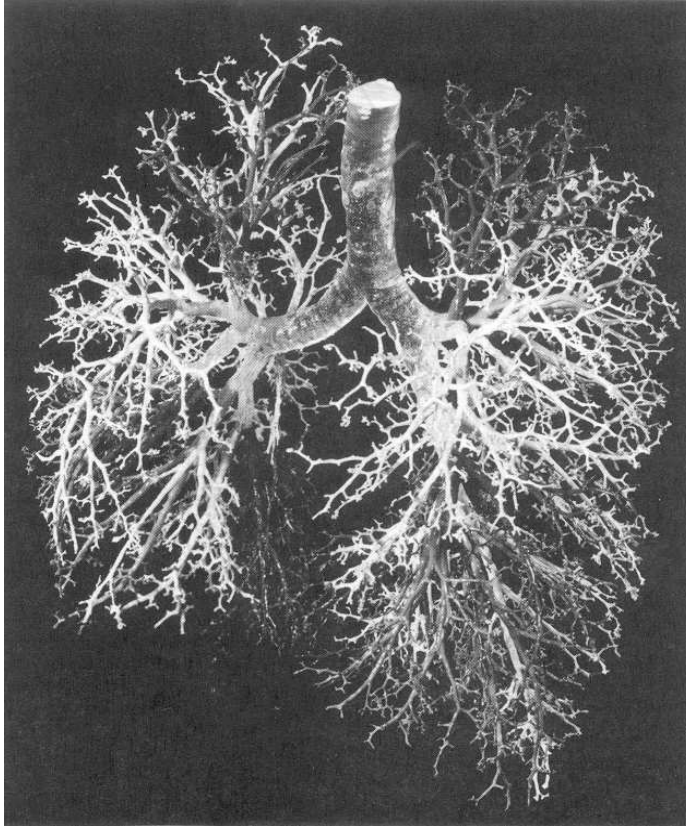

Figure 7.1: The lungs.

reduced to 40 mm Hg.

The lungs have a volume of about three litres in normal respiratory circumstances. The first sixteen generations of *bronchi* (i. e., the tubes which successively branch from the trachea: see figure 7.1) down to the terminal bronchioles have no alveoli, and simply perform the function of conducting towards the respiratory bronchioles, and are for this reason known as the *dead space*. Despite the sixteen generations, they occupy a volume of only 150 ml. Beyond the conducting airways, the respiratory bronchioles have increasing numbers (as they continue to divide) of alveolar sacs attached. This respiratory zone provides most of the lung volume, about three litres.

It is a matter of common experience that normal breathing neither completely empties nor completely fills the lungs. A normal inspiration consists of 500 ml, and this is called the *tidal volume*. Thus in normal breathing, the lung volume varies between about 2.5 and 3 litres. In forced expiration, the lungs cannot be completely emptied; the minimum volume obtainable is the *residual volume*, a bit more than 1 litre. Similarly, there is a maximum obtainable volume on inspiration, the total lung capacity, and this is about 6 litres.

### 7.1.1 The mechanics of breathing

As with the heartbeat, a breath consists of two separate actions: inspiration and expiration. As with the heart, the action is driven by muscular contraction. But unlike the heart, it is the filling (inspiratory) part of the breath which is driven by contraction.

The lungs are contained within the *thoracic cavity* bounded by the chest wall, and effectively glued to it by a thin layer of intrapleural fluid at negative (relative to atmospheric) pressure. However, this fluid lubricates the chest wall, so that the lungs can expand and contract freely during breathing. The lungs are framed by various sets of muscles: most notably the *diaphragm* and the *intercostal muscles*. The diaphragm sits at the base of the rib cage, and when it contracts, the lower surfaces of the lungs are pulled downwards, and the thoracic volume increases. Consequently the intrathoracic pressure decreases, and air is sucked into the lungs. Normal expiration is simply an elastic recoil when the diaphragm relaxes.

Other muscles come into play during exercise. For example, the abdominal muscles contract to assist expiration (try doing sit-ups, and see when you breathe), and the external intercostal muscles assist inspiration by raising the rib cage. The idea that our internal organs are relatively stationary within our bodies is misguided: they all slosh around.

There are several respiratory groups of neurons within the brain. The *dorsal respiratory neurons* in the medulla appear to generate a rhythmic firing pattern in the phrenic nerves which innervate the diaphragm and cause inspiration. How this rhythm is caused or maintained is not known; the mechanism is analogous to the rôle of the pacemaker neurons in the sino-atrial node of the heart.

The *ventral respiratory neurons* are more associated with expiration (in exercise, when the elastic recoil is insufficient). Another group of neurons is the *pneumotaxic centre* in the upper pons, which sends signals to the respiratory centre to control the duration of the inspiratory signals; less well understood is the *apneustic centre* in the lower pons, which sometimes sends signals to the respiratory centre prolonging the inspiratory signal. It is not known whether the apneustic centre plays any rôle in normal respiratory control.

## 7.2 Arterial chemoreceptors and blood gas control

The principal way in which control of normal respiration occurs is through the effect of the blood gases  $O_2$  and  $CO_2$  on two sets of chemoreceptors. There are other receptors, but the chemoreceptors are thought to exert the primary control. This is not true in exercise, where increased ventilation (*hypernea*) occurs (proportionally to oxygen consumption) despite the fact that arterial  $O_2$ ,  $CO_2$  and pH levels are virtually unaltered. The reasons for this are not known, but it may be that control is effected at the neurogenic level. In this chapter we focus on the control of normal respiration by blood gas concentrations.

### 7.2.1 Central chemoreceptors

The central chemoreceptors are located in the medulla, like the dorsal and ventral respiratory neurons. They are thought to lie within 200 microns of the ventral surface of the medulla, which is bathed in *cerebro-spinal fluid* (CSF). They respond to  $H^+$  (low pH means high  $H^+$ , i. e., acid), and ventilation increases with  $H^+$  concentration. However, the blood-brain barrier is relatively impermeable to  $H^+$ , and the central chemoreceptors are effectively stimulated by blood  $CO_2$ , in the following way.  $CO_2$  passes the blood-brain barrier easily, and then diffuses through the medulla towards the CSF and the central chemoreceptors. In the brain extracellular fluid,  $CO_2$  reacts with water, forming acid and bicarbonate ions:

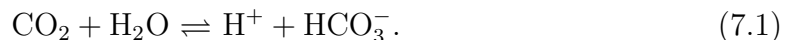

It is the  $H^+$  which is thus formed in the brain tissue which migrates to the central chemoreceptors and causes changes in ventilation.  $CO_2$  thus acts as a surrogate for  $H^+$ , and it is often assumed in models that ventilation is centrally controlled by the the blood concentration of  $CO_2$ . More realistically, this effect is filtered by the delay in diffusing the hydrogen ions across the medulla to the CSF.

### 7.2.2 Peripheral chemoreceptors

The peripheral chemoreceptors are located outside the brain. Most of them are in carotid bodies located at bifurcations in the *carotid arteries*, in the neck. Others are in the aortic arch, nearer the heart, and there are others elsewhere in the arterial system. Afferent nerve fibres from the carotid bodies pass through the *glossopharyngeal nerves*, while those from the aortic bodies pass through the vagal nerves.

The peripheral chemoreceptors respond to  $CO_2$  in much the same functional way as the central chemoreceptors, but the amplitude of the response is much smaller, perhaps a fifth. On the other hand, the response is much more rapid, presumably because of the delay for the central chemoreceptors in transporting hydrogen ions through the medulla.

The other significant feature of the peripheral chemoreceptor response is that it is strongly affected by oxygen. The gain of the  $CO_2$  response increases sharply with reduced oxygen levels. Alternatively, one can say that the peripheral controllers increase ventilation sharply with reducing oxygen, and this response is amplified in *hypercapnea* (elevated levels of  $CO_2$ ).

## 7.3 Periodic breathing

We have talked rather loosely about ventilation  $\dot{V}$ , as if it is a continuously defined quantity. Like the heart rate, this is not actually the case. A typical adult human takes 12–14 breaths per minute, and if each breath is of tidal volume 500 ml, then this gives the *minute ventilation*, or simply the ventilation,  $\dot{V}$ , as 6–7 l min<sup>-1</sup>. Thus



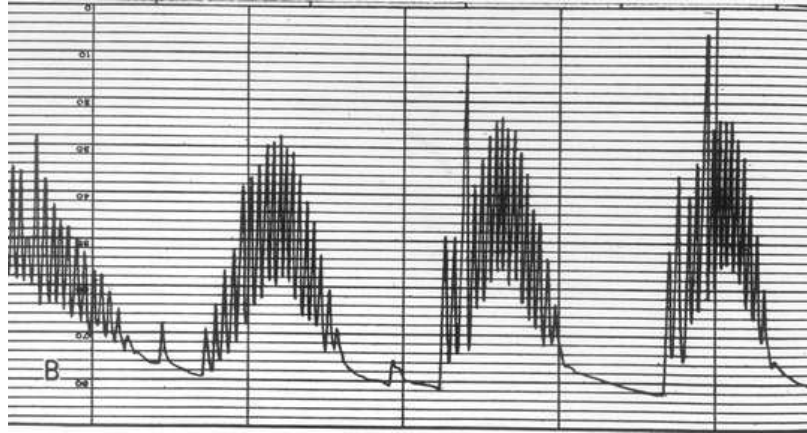

Figure 7.2: Cheyne-Stokes respiration.

the ventilation can be defined as the local time average of the inspired volume per unit time. Normally, this is the same as the averaged expired volume per unit time. Of more relevance is the *alveolar ventilation*: since there is 150 ml dead space, only 350 ml of each breath is involved in gas exchange. This effective alveolar ventilation is thus  $4\text{--}5\text{ l min}^{-1}$ . We can, and do, think of the ventilation as a continuous variable when it changes over time scales much longer than that of a single breath.

One such phenomenon which satisfies this constraint is the phenomenon of periodic breathing, and particularly *Cheyne-Stokes* breathing. Cheyne-Stokes breathing is a rhythmic oscillation in which the depth of breathing first increases and then decreases over an interval of about 30 seconds, and then breathing ceases altogether (*apnea*), perhaps for a further 30 seconds. The pattern then repeats, forming a periodic pattern with a period on the order of a minute. An example is shown in figure 7.2. We will devote the rest of this chapter to a consideration of mechanisms which may explain this peculiar type of breathing.

Cheyne-Stokes breathing occurs in two particular clinical conditions, those of heart failure and stroke. It is thought that the failing heart causes low blood flow, and this leads to an increased delay before the central and peripheral chemoreceptors can respond to changes in arterial  $\text{CO}_2$  concentrations at the lungs; such an increased delay can cause oscillations to occur.

Stroke is associated with damage to the brain, and it is thought that this leads to an increased sensitivity, or gain, in the dependence of ventilation on  $\text{CO}_2$  levels. Again, this is a destabilising effect.

Periodic breathing, not necessarily apneic, occurs also in infants, and it also occurs in climbers at altitude, before they have become fully acclimatised. In this case it can be associated with a steepening of the  $\text{CO}_2$  response curve due to low oxygen levels.

As we have indicated, the classical explanation for Cheyne-Stokes or other periodic breathing is that it arises through an oscillatory (Hopf) destabilisation of steady state ventilation, in which the destabilising parameters are the delay in controller response

due to heart to brain blood transport, and the gain (slope) of the ventilatory CO<sub>2</sub> response curve. A number of models have been proposed to validate this idea, but they are all conceptually similar compartment models. We will describe two: the simplest model due to Mackey and Glass (1977), and the more elaborate Grodins model due to Grodins *et al.* (1967).

## 7.4 The Mackey-Glass model

The model proposed by Mackey and Glass (1977), also expounded in their book (Glass and Mackey 1988) is the simplest model for respiratory control that is consistent with the principal features of the system. It represents the change in CO<sub>2</sub> concentration of a single compartment due to metabolic production and removal by ventilation. Ventilation is controlled by CO<sub>2</sub> levels at the central controller, located in the brain and serviced (with a delay) by blood flow through the carotid artery. We will use partial pressure rather than concentration to describe CO<sub>2</sub> levels, and will denote the CO<sub>2</sub> partial pressure in the single compartment by  $P$ . The Mackey-Glass model is then

$$K \frac{dP}{dt} = M - P\dot{V}. \quad (7.2)$$

Here,  $K$  represents effective compartment volume and  $M$  is metabolic production rate. The question arises, what is the compartment in this model? There are different ways to interpret this, but perhaps the simplest is to suppose that the peripheral tissues constitute the compartment, as illustrated in figure 7.3. The blood flows through the tissues and past the lungs, where gas exchange takes place, and one views the blood flow to the brain as a ‘shunt’ (i. e., a bypass) so that the central controller acts with

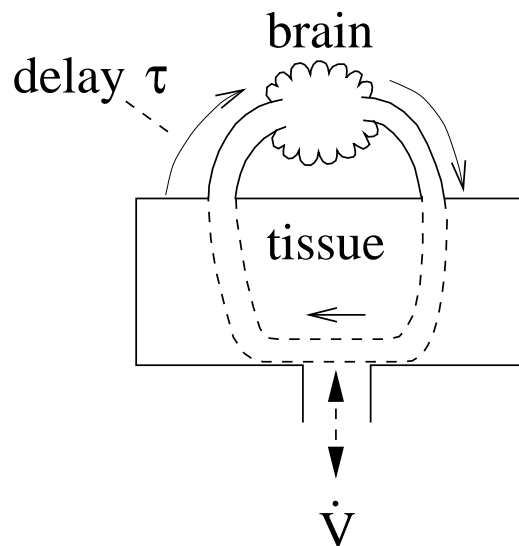

Figure 7.3: A simple one-compartment model of respiratory control.

the delay due to transport from lungs (or heart—in this view there is no distinct pulmonary circulation). It is evident that with this interpretation, one associates no delay in transporting blood to the tissues, and this is one of the potential drawbacks of the model, since in reality the mean transport time to the peripheral tissues is of the order of 30 seconds, much larger than the 10 seconds or so that blood takes to get to the brain.

The ventilation in (7.2) is taken to be a function of  $P(t - \tau)$ , where  $\tau$  is the delay in transport from blood to brain. Mackey and Glass choose a Hill type sigmoidal function, but a more realistic assumption is the piecewise linear function

$$\dot{V} = G_C[P - P_0]_+, \quad (7.3)$$

where  $P_0$  is an apnea threshold and  $G_C$  represents the gain of the central controller. The peripheral controller is ignored in the sense that oxygen is not included in the Mackey-Glass model.

We write the model in dimensionless form by defining

$$t = \tau t^*, \quad P = P_0 + \Delta P p^*, \quad \dot{V} = G_C \Delta P v, \quad (7.4)$$

where  $\Delta P$  is defined by

$$\Delta P = \frac{M}{P_0 G_C}. \quad (7.5)$$

The dimensionless model is then (dropping the asterisks on  $t^*$  and  $p^*$ )

$$\begin{aligned} \dot{p} &= \alpha[1 - (1 + \mu p)v], \\ v &= v(p_1) = [p_1]_+, \end{aligned} \quad (7.6)$$

where  $p_1 \equiv p(t - 1)$ . The parameters are defined by

$$\alpha = \frac{\tau G_C P_0}{K}, \quad \mu = \frac{M}{P_0^2 G_C}. \quad (7.7)$$

We use values  $M = 170$  mm Hg l min<sup>-1</sup>,  $P_0 = 35$  mm Hg,  $G_C = 2$  l min<sup>-1</sup> mm Hg<sup>-1</sup>,  $\tau = 0.2$  min (12 s),  $K = 39$  l, and with these values we find

$$\alpha \approx 0.36, \quad \mu \approx 0.07. \quad (7.8)$$

Evidently the parameter  $\mu \ll 1$ , and we put it to zero. The (unique) steady state is then given by  $p = 1$ , and then also  $v = 1$ . Note that the ventilation scale is  $M/P_0 \approx 4.9$  l min<sup>-1</sup>, as observed (for alveolar ventilation). To examine its linear stability, we put  $p = 1 + \tilde{p}$  and linearise (7.6) (actually, for small  $\mu$  and  $p > -1$ , the equation is already linear): we find

$$\frac{d\tilde{p}}{dt} \approx -\alpha\tilde{p}_1, \quad (7.9)$$

and this has solutions  $\tilde{p} \propto \exp(\sigma t)$  provided

$$\sigma = -\alpha e^{-\sigma}. \quad (7.10)$$

This is a transcendental equation we have seen before in chapter 6 (see figure 6.11). For positive  $\alpha$ , there is a Hopf bifurcation if

$$\alpha = \frac{\tau G_C P_0}{K} \gtrsim \pi/2, \quad (7.11)$$

and the period of the resulting oscillation is approximately four times the delay, i. e.,  $4\tau$ . In dimensional terms this is  $4\tau$ .

This simple theory provides a viable explanation for Cheyne-Stokes breathing, but it is not clear that it is correct. A five fold increase in  $\alpha$  is necessary to promote instability, and this can be attained by a five fold increase in delay, due to a five fold decrease in cardiac output. However, this seems extreme, and indeed, the basic oscillation period would then be about twenty times  $\tau$ , or four minutes — too long. Alternatively, an increase in gain by a factor of five can produce instability, with the period (48 seconds) being approximately correct. Although the basic mechanism may be encapsulated by the Mackey-Glass model, it may also be that the quantitative simplifications which have been made are *too* simple. Next, we consider a more complicated model which bears a closer resemblance to the physiological system.

## 7.5 The Grodins model for CO<sub>2</sub>

The Grodins model (Grodins *et al.* 1967) is a compartment model which describes the oxygen, carbon dioxide and nitrogen concentrations in separate compartments of lungs, brain, tissues, CSF, as well as the arteries and the veins. Nitrogen is passive, and the model uncouples into separate subsystems for CO<sub>2</sub> and O<sub>2</sub>. They are coupled through the dependence of blood flow and ventilation on both blood gases. Here we will ignore the oxygen transport, and discuss only the CO<sub>2</sub> part of the model.

Figure 7.4 shows the schematic arrangement of the compartments of the Grodins model. Blood flows separately to the brain and the other tissues, with four separate delays describing arterial and venous blood flow between lungs and brain and lungs and tissue. Equations describing the evolution of CO<sub>2</sub> concentrations in lungs, brain and tissues are given by Grodins *et al.*'s equations 1.1, 1.4 and 1.7:

$$\begin{aligned} K_L \dot{F}_{\text{ACO}_2} &= V_I F_{\text{ICO}_2} - V_E F_{\text{ACO}_2} + \beta Q [C_{\text{vCO}_2} - C_{\text{aCO}_2}], \\ K_B \dot{C}_{\text{BCO}_2} &= MR_{\text{BCO}_2} + Q_B [C_{\text{aBCO}_2} - C_{\text{vBCO}_2}] - D_{\text{CO}_2} [P_{\text{BCO}_2} - P_{\text{CSFCO}_2}], \\ K_T \dot{C}_{\text{TCO}_2} &= MR_{\text{TCO}_2} + (Q - Q_B) [C_{\text{aTCO}_2} - C_{\text{vTCO}_2}]. \end{aligned} \quad (7.12)$$

In these equations,  $K_L, K_B, K_T$  are the volumes of the lung, brain and tissue compartments, respectively. To be more precise,  $K_L$  is the volume of air in the lungs.  $F_{\text{ACO}_2}$  is the alveolar volume fraction of CO<sub>2</sub> in the lung,  $F_{\text{ICO}_2}$  the inspired CO<sub>2</sub> volume fraction,  $V_I$  and  $V_E$  the inspiratory and expiratory ventilation rates.  $C_{\text{aCO}_2}$  is

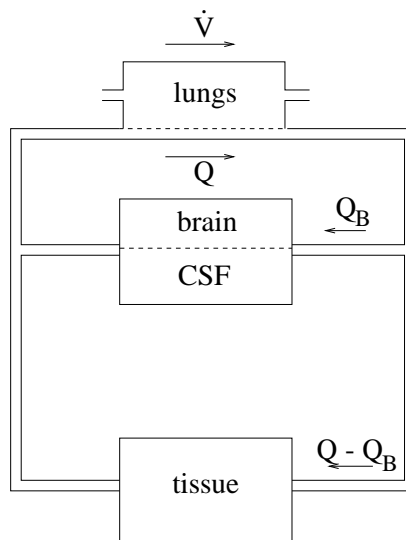

Figure 7.4: Compartments of the Grodins model.

the arterial  $\text{CO}_2$  concentration at the lung,  $C_{v\text{CO}_2}$  the venous  $\text{CO}_2$  concentration at the lung, and  $Q$  is the blood flow rate.

The numerical factor

$$\beta = \frac{863}{B - 47} \quad (7.13)$$

arises for the following reason (West 1990). The blood gas concentrations  $C$  are measured at dry atmospheric conditions, or STPD: standard temperature and pressure, dry. On the other hand, the lung gas fractions  $F$  are measured at BTPS: body temperature and pressure, saturated (with water vapour). To convert a gas volume from STPD to BTPS, we use the gas law  $PV/T = \text{constant}$ , and Dalton's law of partial pressures. Thus if  $B$  is barometric pressure (in units of mmHg:  $1 \text{ mmHg} = 133.3 \text{ Pa}$ , while  $1 \text{ atmosphere} = 1.013 \times 10^5 \text{ Pa}$ , thus standard pressure  $760 \text{ mmHg} \approx 1 \text{ atm}$ ; the related unit  $1 \text{ torr} = 1/760 \text{ atm}$ , so that  $1 \text{ mmHg} \approx 1 \text{ torr}$ ), then the saturated water vapour pressure at  $37^\circ\text{C}$  (body temperature) is  $47 \text{ mmHg}$ , so  $(B - 47) \text{ mmHg}$  is the partial gas pressure. With STPD pressure and temperature of  $760 \text{ mmHg}$  and  $273 \text{ K}$ , and BTPS values  $B - 47$  and  $310$  (degrees Kelvin,  $= 273 + 37$ ), then

$$\frac{760}{273} \text{l(STPD)} = \frac{B - 47}{310} \text{l(BTPS)}, \quad (7.14)$$

whence

$$1 \text{ l(BTPS)} = \beta \text{ l(STPD)}, \quad (7.15)$$

where  $\text{l}$  denotes a litre. At sea level, where  $B = 760$ ,  $\beta = 1.21$ .

Units in  $(7.12)_1$  are  $K_L (\text{l(BTPS)})^2$ ,  $F (\text{l(BTPS)}) (\text{l(BTPS)})^{-1}$ , i. e., dimensionless),

---

<sup>2</sup>This is why  $K_L$  is defined to be the volume of air in the lung: the same quantity of air outside the body would have a different volume.

$V_I$  and  $V_E$  (l(BTPS))  $\text{min}^{-1}$ ),  $Q$  (l  $\text{min}^{-1}$ ) and  $C$  (l(STPD)l $^{-1}$ ), and with the definition of  $\beta$  in (7.15), we see that these are consistent.

Other terms in (7.12) are the metabolic production rates of  $\text{CO}_2$  in brain ( $MR_{\text{BCO}_2}$ ) and tissues ( $MR_{\text{TCO}_2}$ ), the brain blood flow  $Q_B$ , the partial pressure of  $\text{CO}_2$  in brain ( $P_{\text{BCO}_2}$ ) and cerebro-spinal fluid ( $P_{\text{CSFCO}_2}$ ), a transport coefficient ( $D_{\text{CO}_2}$ ) across the blood-brain barrier through the medulla to the cerebro-spinal fluid, and concentrations of  $\text{CO}_2$  on arterial (a) and venous (v) side of brain (B) and tissues (T):  $C_{\text{aBCO}_2}$ ,  $C_{\text{vBCO}_2}$ ,  $C_{\text{aTCO}_2}$ ,  $C_{\text{vTCO}_2}$ .

In our discussion of these equations, we take

$$\begin{aligned} C_{\text{vBCO}_2} &= C_{\text{BCO}_2}, \\ C_{\text{vTCO}_2} &= C_{\text{TCO}_2}, \end{aligned} \quad (7.16)$$

and we take the values of  $C_{\text{aB}}$  and  $C_{\text{aT}}$  as those of  $C_{\text{a}}$  with an appropriate transport delay:

$$\begin{aligned} C_{\text{aBCO}_2} &= C_{\text{aCO}_2}(t - \tau_{\text{aB}}), \\ C_{\text{aTCO}_2} &= C_{\text{aCO}_2}(t - \tau_{\text{aT}}). \end{aligned} \quad (7.17)$$

Inspiratory  $\text{CO}_2$  ( $F_{\text{ICO}_2}$ ) is prescribed, and normally will be zero; the remaining variables in the equations are thus  $F_{\text{ACO}_2}$ ,  $C_{\text{vCO}_2}$ ,  $C_{\text{aCO}_2}$ ,  $C_{\text{BCO}_2}$ ,  $C_{\text{TCO}_2}$ . In the Grodins model, their final equation 8.7 expresses the definition of venous  $\text{CO}_2$  in terms of brain and tissue  $\text{CO}_2$ :

$$QC_{\text{vCO}_2} = Q_B C_{\text{BCO}_2}(t - \tau_{\text{vB}}) + (Q - Q_B)C_{\text{TCO}_2}(t - \tau_{\text{vT}}), \quad (7.18)$$

$\tau_{\text{vB}}$  and  $\tau_{\text{vT}}$  being venous transport delays from brain to lung and tissue to lung, respectively.

We wish to write (7.12) in terms of partial pressures. In order to do this, we need to write volume fractions  $F$  (dimensionless) and concentrations  $C$  (l(STPD) l $^{-1}$ ) in terms of partial pressures  $P$  (mm Hg). According to Dalton's law

$$F_{\text{ACO}_2} = \frac{P_{\text{ACO}_2}}{B - 47}, \quad (7.19)$$

where  $B - 47$  has units of mm Hg, and we make the additional assumption that the arterial blood leaving the pulmonary capillary bed is in equilibrium with the alveolar concentration, thus

$$P_{\text{aCO}_2} = P_{\text{ACO}_2}. \quad (7.20)$$

In addition, concentrations  $C$  are related to partial pressure  $P$  by dissociation curves. The  $\text{CO}_2$  dissociation curve relating  $C_{\text{aCO}_2}$  to  $P_{\text{ACO}_2}$  is given in the Grodins model by their equation 3.1. Assuming that log means  $\log_{10}$ , this can be written in the form ( $C = C_{\text{aCO}_2}$ ,  $P = P_{\text{ACO}_2}$ )

$$P = Q(C - \Sigma P) \exp[R(C - \Sigma P)], \quad (7.21)$$

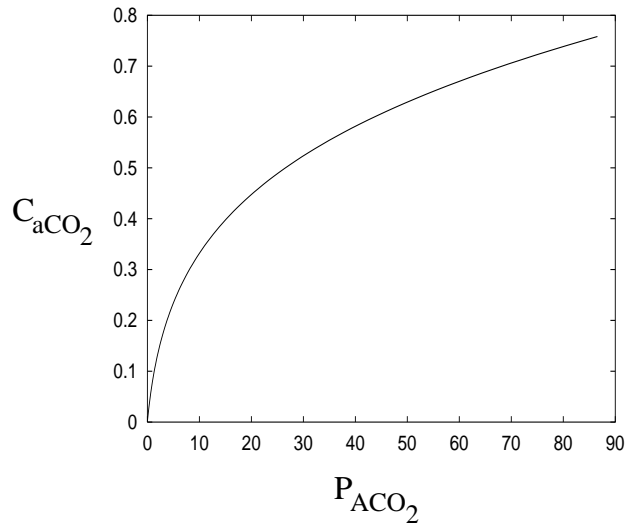

Figure 7.5: The Grodins formula 3.1 for the saturation curve relating  $C_{aCO_2}$  to  $P_{ACO_2}$ , exhibiting the Haldane effect.

where from the Grodins appendix I, we have

$$Q \approx 9.19, \quad R \approx 3.71, \quad \Sigma \approx 0.00067. \quad (7.22)$$

This is plotted in figure 7.5, and in figure 7.6 we show a close up for  $P$  between 30 and 50 mm Hg, which shows that a useful linear approximation is

$$C \approx 0.38 + 0.005 P, \quad (7.23)$$

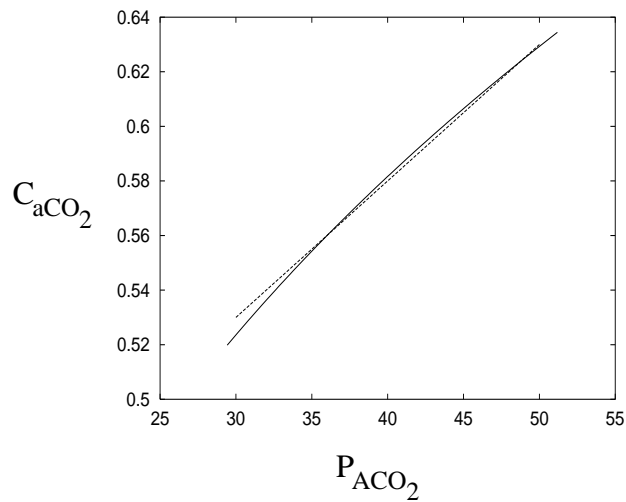

Figure 7.6: Close up of part of figure 7.5, together the linear fit from (7.23).

where  $C$  is in l(STPD)  $l^{-1}$  and  $P$  is in mm Hg. More generally, we take the dissociation curves to be of the form

$$\begin{aligned} C_{aCO_2} &= K_1 + K_{CO_2} P_{aCO_2}, \\ C_{vCO_2} &= K_1 + K_{CO_2} P_{vCO_2}, \\ C_{aBCO_2} &= K_1 + K_{BCO_2} P_{aBCO_2}, \\ C_{vBCO_2} &= K_1 + K_{BCO_2} P_{vBCO_2}, \end{aligned} \quad (7.24)$$

where  $K_{CO_2} \approx 0.005$  l(STPD)  $l^{-1}$  mm Hg $^{-1}$ . In the Grodins model, the buffering relations proposed by Grodins et al (their equations 4.1, 4.2) relating  $C_{BCO_2}$  and  $C_{vBCO_2}$  to  $P_{BCO_2}$  are similar to the alveolar/arterial relation. Therefore we will also take  $K_{BCO_2} = K_{CO_2}$  in (7.24).

We can now write the Grodins model (7.12) in the form, using (7.16) and (7.17),

$$\begin{aligned} K_L \dot{P}_{aCO_2} &= -V_E P_{aCO_2} + 863 K_{CO_2} Q [P_{vCO_2} - P_{aCO_2}], \\ K_{CO_2} K_B \dot{P}_{BCO_2} &= MR_{BCO_2} + K_{CO_2} Q_B [P_{aCO_2}(t - \tau_{aB}) - P_{BCO_2}] \\ &\quad - D_{CO_2} [P_{BCO_2} - P_{CSFCO_2}], \\ K_{CO_2} K_T \dot{P}_{TCO_2} &= MR_{TCO_2} + (Q - Q_B) K_{CO_2} [P_{aCO_2}(t - \tau_{aT}) - P_{TCO_2}]. \end{aligned} \quad (7.25)$$

These must be supplemented by (7.18), which we write in the form

$$Q P_{vCO_2} = Q_B P_{BCO_2}(t - \tau_{vB}) + (Q - Q_B) P_{TCO_2}(t - \tau_{vT}). \quad (7.26)$$

In addition, the CSF  $CO_2$  partial pressure satisfies Grodins *et al.*'s equation 1.10:

$$K_{CSF} k \alpha_{CO_2} \dot{P}_{CSFCO_2} = D_{CO_2} (P_{BCO_2} - P_{CSFCO_2}), \quad (7.27)$$

in which  $K_{CSF}$  is CSF volume,  $k$  is a conversion factor from atmospheric pressure to mm Hg (thus  $k = 1/760$ ), and  $\alpha_{CO_2}$  is a solubility coefficient for  $CO_2$  in CSF. Values for the parameters in the model are given in table 7.1.

### Arterial and venous delays

In the Grodins model there four separate delays:  $\tau_{aB}$ ,  $\tau_{aT}$ ,  $\tau_{vB}$  and  $\tau_{vT}$ , representing the blood transport time from heart to brain, heart to tissues, brain to heart, and tissues to heart. Their definitions are similar, and exemplified by that for  $\tau_{aB}$ :

$$\tau_{aB} = \frac{V_{aB} (\tau_{aB} - \tilde{\tau}_{aB})}{\int_{t-\tau_{aB}}^{t-\tilde{\tau}_{aB}} Q dt} + \frac{\tilde{V}_{aB} \tilde{\tau}_{aB}}{\int_{t-\tilde{\tau}_{aB}}^t (Q - Q_B) dt}; \quad (7.28)$$

the definitions of the other delays are completely analogous.

To understand how such terms arise, suppose that points  $R$  and  $S$  are joined by an artery of volume  $V_{RS}$  through which blood flows at a variable rate  $Q(t)$ . If the blood at point  $S$  at time  $t$  was at point  $R$  at time  $t - \tau_{RS}$ , then the volume  $V$  of artery



Symbol	Units	Typical value
$Q_B^*$	$l \text{ min}^{-1}$	0.75
$Q^*$	$l \text{ min}^{-1}$	6
$V^*$	$l(\text{BTPS}) \text{ min}^{-1}$	5
$K_L$	$l(\text{BTPS})$	3
$K_B$	1	1
$K_T$	1	39
$K_{\text{CSF}}$	1	0.1
$K_{\text{CO}_2}$	$l(\text{STPD}) l^{-1} \text{ mm Hg}^{-1}$	0.005
$MR_{\text{BCO}_2}$	$l(\text{STPD}) \text{ min}^{-1}$	0.05
$MR_{\text{TCO}_2}$	$l(\text{STPD}) \text{ min}^{-1}$	0.182
$P^*$	mm Hg	40
$D_{\text{CO}_2}$	$l(\text{STPD}) \text{ min}^{-1} \text{ mm Hg}^{-1}$	$0.82 \times 10^{-5}$
$\tau_{\text{aB}}$	min (sec)	0.18 (11)
$\tau_{\text{aT}}$	min (sec)	0.32 (19)
$\tau_{\text{vT}}$	min (sec)	0.59 (35)
$\tau_{\text{vB}}$	min (sec)	0.11 (7)
863	$\text{mm Hg } l(\text{BTPS}) l(\text{STPD})^{-1}$	863
$k$	$\text{atm mm Hg}^{-1}$	0.0013
$\alpha_{\text{CO}_2}$	$l(\text{STPD}) l^{-1} \text{ atm}^{-1}$	0.51

Table 7.1: Parameter values for the Grodins model.

traversed satisfies  $\frac{dV}{ds} = Q(s)$ ,  $V = 0$  at  $s = t - \tau_{\text{RS}}$ ,  $V = V_{\text{RS}}$  at  $s = t$ . Integrating this, we find  $V_{\text{RS}} = \int_{t-\tau_{\text{RS}}}^t Q(s) ds$ .

If now a flow  $Q(t)$  traverses a volume  $V_{\text{aB}}$  from the heart to the point  $C$ , and then branches, so that a sub-flow  $Q_B$  traverses a further arterial volume  $\tilde{V}_{\text{aB}}$  from  $C$  to  $B$ , then the blood which is at  $B$  at time  $t$  is at  $C$  at time  $t - \tilde{\tau}_{\text{aB}}$ , and at the heart at time  $t - \tau_{\text{aB}}$ , where

$$V_{\text{aB}} = \int_{t-\tau_{\text{aB}}}^{t-\tilde{\tau}_{\text{aB}}} Q(s) ds, \quad \tilde{V}_{\text{aB}} = \int_{t-\tilde{\tau}_{\text{aB}}}^t Q_B(s) ds, \quad (7.29)$$

and these relations are the basis for (7.28). In similar manner, we have

$$\begin{aligned} V_{\text{aT}} &= \int_{t-\tau_{\text{aT}}}^{t-\tilde{\tau}_{\text{aT}}} Q(s) ds, & \tilde{V}_{\text{aT}} &= \int_{t-\tilde{\tau}_{\text{aT}}}^t (Q(s) - Q_B(s)) ds, \\ V_{\text{vB}} &= \int_{t-\tau_{\text{vB}}}^{t-\tilde{\tau}_{\text{vB}}} Q_B(s) ds, & \tilde{V}_{\text{vB}} &= \int_{t-\tilde{\tau}_{\text{vB}}}^t Q(s) ds, \\ V_{\text{vT}} &= \int_{t-\tau_{\text{vT}}}^{t-\tilde{\tau}_{\text{vT}}} (Q(s) - Q_B(s)) ds, & \tilde{V}_{\text{vT}} &= \int_{t-\tilde{\tau}_{\text{vT}}}^t Q(s) ds. \end{aligned} \quad (7.30)$$

The values of the arterial and venous volumes in the Grodins model are given in table 7.2.

Volume	Value (litres)
$V_{aB}$	1.062
$\tilde{V}_{aB}$	0.015
$V_{aT}$	1.062
$\tilde{V}_{aT}$	0.735
$V_{vB}$	0.06
$\tilde{V}_{vB}$	0.188
$V_{vT}$	2.94
$\tilde{V}_{vT}$	0.188

Table 7.2: Arterial and venous volumes. These values include atrial and ventricular components.

### 7.5.1 Central and peripheral controllers

In assessing the effects of both sets of controlling chemoreceptors on ventilation, it is difficult to separate the two. Generally, it is assumed that the effects are additive, thus

$$V_I = V_C + V_P, \quad (7.31)$$

where  $V_I$  is the (inspiratory, assumed equal to expiratory,  $V_E$ ) ventilation,  $V_C$  is the centrally controlled ventilation, and  $V_P$  is the peripherally controlled ventilation.

The peripheral ventilation responds to  $\text{CO}_2$  more or less linearly above a threshold, and the slope (gain) of the response is modulated by  $\text{O}_2$ . This is modelled by taking

$$V_P = G_P [P_{a\text{CO}_2}(t - \tau_{a0}) - I_P]_+, \quad (7.32)$$

which is a form of controller suggested by Khoo *et al.* (1982)<sup>3</sup>. In these expressions,  $[x]_+ = \max(x, 0)$ ,  $\tau_{a0}$  represents the delay in transport between lung and carotid body, and  $I_P$  is a threshold value for activation of the peripheral controller. The value of  $\tau_{a0}$  is almost the same as  $\tau_{aB}$ , and we will assume they are the same.

In a similar manner, the Khoo central controller is of the form

$$V_C = G_C [P_{B\text{CO}_2} - I_C]_+, \quad (7.33)$$

and is supposed to respond directly to brain  $\text{CO}_2$ . As we have seen, this is not thought to be physiologically correct, and a better assumption is

$$V_C = G_C [P_{\text{CSF}\text{CO}_2} - I_C]_+. \quad (7.34)$$

---

<sup>3</sup>The actual form of the controller was  $V_P = \tilde{G}_P \exp[-0.05 P_{a\text{O}_2}(t - \tau_{a0})][P_{a\text{CO}_2}(t - \tau_{a0}) - I_P]_+$ , but we assume in the present discussion that  $P_{a\text{O}_2}$  is constant and equal to 100 mm Hg. The value of  $G_P$  in table 7.3 reflects this assumption

Parameter	Units	Value
$G_P$	l(BTPS) $\text{min}^{-1}$ mm Hg $^{-1}$	0.2
$G_C$ (Khoo)	l(BTPS) $\text{min}^{-1}$ mm Hg $^{-1}$	1.8
$G_C$ (Grodins)	l(BTPS) $\text{min}^{-1}$ mm Hg $^{-1}$	1.04
$I_P$	mm Hg	35
$I_C$	mm Hg	49.3

Table 7.3: Controller parameters.  $G_P$  and  $G_C$  (Khoo) are from Batzel and Tran (2000a) (assuming arterial oxygen partial pressure of 100 mm Hg),  $G_C$  (Grodins) is derived from Grodins *et al.* (1967) (their equations 9.2. and 6.1). The values of  $I_P$  and  $I_C$  are chosen so that a steady state alveolar ventilation rate of 5 l  $\text{min}^{-1}$  is obtained when  $P_{\text{asCO}_2} = 40$  mm Hg (see the discussion after (7.49)).

(More specifically, the dependence is on  $\text{H}^+$ , but this is directly related to  $P_{\text{CSFCO}_2}$  via the acid-base buffering relation (equation 6.1 of Grodins *et al.* (1967)).) Values of the controller parameters are given in table 7.3.

## 7.6 Non-dimensionalisation

Typical observed values of ventilation, blood flow and arterial  $\text{CO}_2$  partial pressure are denoted by  $V^*$ ,  $Q^*$  and  $P^*$  respectively; representative values are 5 l  $\text{min}^{-1}$ , 6 l  $\text{min}^{-1}$  and 40 mm Hg. A typical value of the blood flow to the brain is  $Q_B^*$ , and is 0.75 l  $\text{min}^{-1}$ . We therefore define dimensionless blood flows  $q$ ,  $q_B$  and ventilation rate  $v$  by

$$Q = Q^* q, \quad Q_B = Q_B^* q_B, \quad (7.35)$$

and

$$V_I = V^* v. \quad (7.36)$$

The  $\text{CO}_2$  partial pressure in the blood is determined by a balance between metabolic production and its removal by ventilation. It is easy to solve (7.25), (7.26) and (7.27) to find the steady state partial pressures in terms of (constant) ventilation  $V^*$  and blood flows  $Q^*$  and  $Q_B^*$ . These are

$$P_{\text{aCO}_2} = P^*, \quad (7.37)$$

where we now explicitly define

$$P^* = \frac{863}{V^*} [MR_{\text{TCO}_2} + MR_{\text{BCO}_2}], \quad (7.38)$$

and the conversion factor 863 is the same as that in (7.25). Then,

$$\begin{aligned} P_{\text{vCO}_2} &= P^*(1 + \varepsilon), \\ P_{\text{CSFCO}_2} = P_{\text{BCO}_2} &= P^*(1 + \varepsilon a), \\ P_{\text{TCO}_2} &= P^*(1 + \varepsilon b), \end{aligned} \quad (7.39)$$

where

$$\varepsilon = \frac{V^*}{863 K_{\text{CO}_2} Q^*}, \quad (7.40)$$

and

$$a = \left( \frac{Q^*}{Q_B^*} \right) \left( \frac{MR_{\text{BCO}_2}}{MR_{\text{TCO}_2} + MR_{\text{BCO}_2}} \right), \quad b = \left( \frac{Q^*}{Q^* - Q_B^*} \right) \left( \frac{MR_{\text{TCO}_2}}{MR_{\text{TCO}_2} + MR_{\text{BCO}_2}} \right). \quad (7.41)$$

In scaling the blood  $\text{CO}_2$  partial pressure, we note that  $\text{CO}_2$  levels in the body do not vary enormously, and this is manifested in (7.39) by the parameter  $\varepsilon$ , which is found from table 7.1 to be relatively small,  $\varepsilon \approx 0.19$ . For example, venous blood returning to the lungs may only have a  $\text{CO}_2$  partial pressure of 45 mm Hg. (The values of  $a$  and  $b$  in (7.39) are  $O(1)$ ,  $a \approx 1.72$ ,  $b \approx 0.9$ .) Thus the significant scale for the  $\text{CO}_2$  variables is their variation about this typical value. Therefore we non-dimensionalise the pressure variables by writing

$$\begin{aligned} P_{\text{aCO}_2} &= P^*[1 + \varepsilon p_a], & P_{\text{vCO}_2} &= P^*[1 + \varepsilon p_v], \\ P_{\text{CSFCO}_2} &= P^*[1 + \varepsilon p_C], & P_{\text{BCO}_2} &= P^*[1 + \varepsilon p_B], & P_{\text{TCO}_2} &= P^*[1 + \varepsilon p_T]. \end{aligned} \quad (7.42)$$

Finally we choose the dimensionless time scale

$$t \sim \frac{K_B}{Q_B^*}. \quad (7.43)$$

The dimensionless form of the equations (7.25), (7.26) and (7.27) is then

$$\begin{aligned} \dot{p}_a &= \Lambda [q(p_v - p_a) - (1 + \varepsilon p_a)v], \\ \dot{p}_B &= a + q_B [p_a(t - \tau_{\text{aB}}^*) - p_B] - \nu(p_B - p_C), \\ \dot{p}_T &= s \left[ b + \left( \frac{q - \delta q_B}{1 - \delta} \right) \{p_a(t - \tau_{\text{aT}}^*) - p_T\} \right], \\ \dot{p}_C &= \mu(p_B - p_C), \\ p_v &= p_T(t - \tau_{\text{vT}}^*) + \frac{\delta q_B}{q} [p_B(t - \tau_{\text{vB}}^*) - p_T(t - \tau_{\text{vT}}^*)]. \end{aligned} \quad (7.44)$$

The new parameters appearing in these equations are defined as follows:

$$\begin{aligned} \delta &= \frac{Q_B^*}{Q^*}, & \Lambda &= \frac{863 K_{\text{CO}_2} Q^* K_B}{K_L Q_B^*}, & s &= \frac{(Q^* - Q_B^*) K_B}{K_T Q_B^*}, \\ \mu &= \frac{D_{\text{CO}_2} K_B}{K_{\text{CSF}} k \alpha_{\text{CO}_2} Q_B^*}, & \nu &= \frac{D_{\text{CO}_2}}{K_{\text{CO}_2} Q_B^*}. \end{aligned} \quad (7.45)$$

Parameter	Value	Parameter	Value
$V_{aB}^*$	0.133	$\tau_{aB}^*$	0.148
$\tilde{V}_{aB}^*$	0.015	$\tilde{\tau}_{aB}^*$	0.015
$V_{aT}^*$	0.133	$\tau_{aT}^*$	0.238
$\tilde{V}_{aT}^*$	0.092	$\tilde{\tau}_{aT}^*$	0.105
$V_{vB}^*$	0.06	$\tau_{vB}^*$	0.084
$\tilde{V}_{vB}^*$	0.024	$\tilde{\tau}_{vB}^*$	0.024
$V_{vT}^*$	0.368	$\tau_{vT}^*$	0.444
$\tilde{V}_{vT}^*$	0.024	$\tilde{\tau}_{vT}^*$	0.024

Table 7.4: Typical dimensionless blood volumes in (7.47), and the resulting dimensionless delays assuming constant blood flow,  $q = q_B = 1$ .

### 7.6.1 Dimensionless delays

The dimensionless delays  $\tau_{pq}^*$  are defined, from (7.29) and 7.30), via the relations

$$\begin{aligned}
V_{aB}^* &= \int_{t-\tau_{aB}^*}^{t-\tilde{\tau}_{aB}^*} q(s) ds, & \tilde{V}_{aB}^* &= \int_{t-\tilde{\tau}_{aB}^*}^t q_B(s) ds, \\
V_{aT}^* &= \int_{t-\tau_{aT}^*}^{t-\tilde{\tau}_{aT}^*} q(s) ds, & \tilde{V}_{aT}^* &= \int_{t-\tilde{\tau}_{aT}^*}^t (q(s) - \delta q_B(s)) ds, \\
V_{vB}^* &= \int_{t-\tau_{vB}^*}^{t-\tilde{\tau}_{vB}^*} q_B(s) ds, & \tilde{V}_{vB}^* &= \int_{t-\tilde{\tau}_{vB}^*}^t q(s) ds, \\
V_{vT}^* &= \int_{t-\tau_{vT}^*}^{t-\tilde{\tau}_{vT}^*} (q(s) - \delta q_B(s)) ds, & \tilde{V}_{vT}^* &= \int_{t-\tilde{\tau}_{vT}^*}^t q(s) ds,
\end{aligned} \tag{7.46}$$

and the dimensionless blood volumes are defined by

$$\begin{aligned}
V_{aB}^* &= \frac{\delta V_{aB}}{K_B}, & \tilde{V}_{aB}^* &= \frac{\tilde{V}_{aB}}{K_B}, \\
V_{aT}^* &= \frac{\delta V_{aT}}{K_B}, & \tilde{V}_{aT}^* &= \frac{\delta \tilde{V}_{aT}}{K_B}, \\
V_{vB}^* &= \frac{V_{vB}}{K_B}, & \tilde{V}_{vB}^* &= \frac{\delta \tilde{V}_{vB}}{K_B}, \\
V_{vT}^* &= \frac{\delta V_{vT}}{K_B}, & \tilde{V}_{vT}^* &= \frac{\delta \tilde{V}_{vT}}{K_B}.
\end{aligned} \tag{7.47}$$

Using table 7.2, we find typical values of these dimensionless volumes to be those shown in table 7.4; the corresponding values of the delays for constant blood flow ( $q = q_B = 1$ ) are also shown.

## 7.6.2 Dimensionless controllers

The controllers (7.32), (7.33) and (7.34) can be written in the dimensionless form

$$\begin{aligned} v_P &= [J_P + \gamma_P p_a]_+, \\ v_C &= [J_C + \gamma_C (p_B - a)]_+, \quad (\text{Khoo}) \\ v_C &= [J_C + \gamma_C (p_C - a)]_+, \quad (\text{Grodins}) \end{aligned} \quad (7.48)$$

where the definitions of the parameters are

$$\begin{aligned} J_P &= \frac{G_P (P^* - I_P)}{V^*}, & \gamma_P &= \frac{G_P [MR_{\text{TCO}_2} + MR_{\text{BCO}_2}]}{K_{\text{CO}_2} Q^* V^*}, \\ J_C &= \frac{G_C}{V^*} \left[ P^* - I_C + \frac{MR_{\text{BCO}_2}}{K_{\text{CO}_2} Q_B^*} \right], & \gamma_C &= \frac{G_C [MR_{\text{TCO}_2} + MR_{\text{BCO}_2}]}{K_{\text{CO}_2} Q^* V^*}, \end{aligned} \quad (7.49)$$

using (7.38) and (7.40). For  $G_k = 1 \text{ l(BTPS) min}^{-1} \text{ mm Hg}^{-1}$ ,  $\gamma_k = 1.55$ .

If we suppose peripheral control provides one fifth of the ventilatory drive, then in a steady state,  $J_C = 0.8$ ,  $J_P = 0.2$ , and this is consistent with the parameter choices in table 7.3, if we select the Grodins value  $G_C = 1 \text{ l(BTPS) min}^{-1} \text{ mm Hg}^{-1}$  as well as  $G_P = 0.2 \text{ l(BTPS) min}^{-1} \text{ mm Hg}^{-1}$ . In fact the constraint

$$J_P + J_C = 1 \quad (7.50)$$

(i. e.,  $V_I = V^*$  in steady state) provides a second relation between  $V^*$  and  $P^*$  to supplement (7.38), and from these, explicit values for  $V^*$  and  $P^*$  can be determined.

## 7.7 A simplified model

Typical values of the dimensionless parameters in the model are given in table 7.5. Note that the time scale  $K_B/Q_B^* \approx 80 \text{ s}$ , which is the time scale of interest for Cheyne-Stokes breathing; therefore we study (7.44) on the basis that  $t \sim O(1)$ . We now use the parameter sizes to simplify the model.

We consider the equations in (7.44) in turn. In the  $p_a$  equation,  $\Lambda$  is large, so that  $p_a$  rapidly tends to a quasi-equilibrium, in which

$$v \approx q(p_v - p_a), \quad (7.51)$$

where we additionally use the approximation that  $\varepsilon \ll 1$ . Next, the intra-cranial transport coefficient  $\nu$  is small in (7.44)<sub>2</sub>, so that

$$\dot{p}_B \approx a + q_B [p_a(t - \tau_{aB}^*) - p_B]. \quad (7.52)$$

In the third equation,  $s$  is relatively small, indicating that tissue  $\text{CO}_2$  changes on a long time scale, of order seven minutes. On the  $O(1)$  time scale,  $p_T$  is effectively

Parameter	Value
$\varepsilon$	0.19
$\delta$	0.13
$\Lambda$	11.5
$s$	0.18
$\mu$	0.165
$\nu$	0.0022
$a$	1.7
$b$	0.9
$J_P$	0.2
$J_C$	0.8
$\gamma_P$	0.3
$\gamma_C$	1.5

Table 7.5: Typical dimensionless parameter values.

constant, and its slow evolution is described by the method of averaging. We take a local time average of (7.44)<sub>3</sub>, which yields (neglecting  $O(\delta)$ )

$$\dot{p}_T \approx s \left[ b + \overline{q \{p_a(t - \tau_{aT}^*)\}} - \bar{q} p_T \right], \quad (7.53)$$

where the overbar denotes the local time average, and can be taken as

$$\bar{p} = \frac{1}{T_{\text{av}}} \int_{t-T_{\text{av}}}^t p dt, \quad (7.54)$$

in which formally  $1 \ll T_{\text{av}} \ll 1/s$ . After a slow transient, tissue CO<sub>2</sub> relaxes to a quasi-equilibrium in which it follows the mean arterial pressure, thus

$$p_T \approx \frac{\overline{q \{p_a(t - \tau_{aT}^*)\}}}{\bar{q}}. \quad (7.55)$$

Next, the intra-cranial transport term  $\mu$  in (7.44)<sub>4</sub> is also small, comparable to  $s$ , but not completely negligible. In fact, we can simply integrate this equation. Again, after a relatively long transient, the solution can be written in the delayed integral form,

$$p_C \approx \int_0^\infty p_B(t-s) k(s) ds, \quad (7.56)$$

where the delay kernel

$$k(s) = \mu e^{-\mu s}. \quad (7.57)$$

Since  $\mu$  is small, (7.56) is adequately approximated by the averaging result,

$$p_C \approx \bar{p}_B. \quad (7.58)$$

The final equation in (7.44) can be approximated by

$$p_v \approx p_T(t - \tau_{vT}^*), \quad (7.59)$$

since  $\delta$  is small. Since  $p_T$  is slowly varying, so also is  $p_v$ , and the  $(O(1))$  delay in (7.7.9) is irrelevant, i. e.,  $p_v \approx p_T$ .

In the Grodins model, blood flow is variable, and  $q$  and  $q_B$  satisfy first order differential equations with a response time (due to the sympathetic system) of order ten seconds, and thus relatively rapid. Here we will simply suppose that the blood flows are constant; then the delays are constant, and have the values indicated in table 7.4. There is some justification for this, because of the relatively rapid adjustment of blood flow towards equilibrium, although this equilibrium depends on blood gases to some extent.

With  $q = q_B = 1$ ,  $p_a = p_v - v$ ,  $p_v = p_T = \bar{p}_a$ , whence (7.51) implies

$$\bar{v} = 1, \quad (7.60)$$

and  $p_B$  satisfies

$$\dot{p}_B \approx a + p_v - v(t - \tau_{aB}^*) - p_B. \quad (7.61)$$

Averaging this equation and using (7.60) implies

$$a + p_v = 1 + \bar{p}_B, \quad (7.62)$$

and thus finally

$$\dot{p}_B \approx 1 + \bar{p}_B - v(t - \tau_{aB}^*) - p_B. \quad (7.63)$$

(7.63) and (7.60) constitute the final reduced form of the Grodins model. It is a single delay differential equation which is similar to the Mackey-Glass model, except that it explicitly depends on the long term average brain CO<sub>2</sub> concentration.

### 7.7.1 Stability

For simplicity, we ignore the peripheral controller (or, we lump its effect into that of the central controller). Therefore, we take the ventilation to be of the form

$$v(p_k) = [1 + \gamma(p_k - a)]_+, \quad (7.64)$$

where for the Khoo controller,  $p_k = p_B$ , and for the Grodins controller,  $p_k = p_C$ .

#### Khoo controller, $v(p_B)$

We write

$$p_B = a + p, \quad (7.65)$$

so that  $p = 0$  is the rest state. Denoting also the delay as  $\tau_{aB}^* = \tau$ , and writing  $p(t - \tau) \equiv p_\tau$ , (7.63) becomes

$$\dot{p} \approx 1 + \bar{p} - [1 + \gamma p_\tau]_+ - p. \quad (7.66)$$



The (unique) steady state of the equation

$$\dot{p} = f[p(t - \tau)] - p, \quad (7.67)$$

in which  $f' < 0$ , is oscillatorily unstable if  $|f'| > 1$  at the steady state, and

$$\tau > \frac{\pi - \cos^{-1}(1/|f'|)}{[|f'|^2 - 1]^{1/2}}, \quad (7.68)$$

where  $0 < \cos^{-1}(1/|f'|) < \pi/2$ . The frequency  $\Omega$  of the resulting oscillation, at the bifurcation point, is

$$\Omega = \frac{[\pi - \cos^{-1}(1/|f'|)]}{\tau}, \quad (7.69)$$

and the resulting period,  $2\pi/\Omega$ , lies between  $2\tau$  and  $4\tau$ .

For (7.66) we have instability if

$$\tau_{aB}^* > \frac{\pi - \cos^{-1}(1/\gamma)}{[\gamma^2 - 1]^{1/2}}. \quad (7.70)$$

Since  $\tau_{aB}^* \approx 0.14$  is small, instability occurs when  $\gamma$  is large, and  $\cos^{-1}(1/\gamma) \approx \pi/2$ . Thus instability occurs for

$$\gamma \gtrsim \gamma_c = \frac{\pi}{2\tau_{aB}^*} \approx 11.2 \quad (7.71)$$

with period  $P \approx 4\tau_{aB}^*$ . (The exact value of  $\gamma_c$  from (7.70) is 11.865 when  $\tau_{aB}^* = 0.14$ .) The dimensional period is approximately four times the lung to brain arterial delay,  $4\tau_{aB}$ . In normal circumstances, this is about 45 seconds, and comparable to the observed periods. In fact, a slightly reduced cardiac output will increase the delay, consistent with periods of order a minute, and also with the fact that congestive heart failure will cause such a reduced output.

Using the definition of  $\gamma$  in (7.49), that of  $P^*$  in (7.38), and that  $\tau_{aB}^* = Q_B^* \tau_{aB} / K_B$ , we have the instability criterion in the form

$$\gamma \tau_{aB}^* = \left( \frac{A \tau_{aB} P^* G_C}{K_B} \right) \frac{Q_B^*}{Q^*} \gtrsim \frac{\pi}{2}, \quad (7.72)$$

where

$$A = \frac{1}{863 K_{CO_2}} \approx 0.23 \text{ l(BTPS)}^{-1}. \quad (7.73)$$

This criterion can be directly compared with the Mackey-Glass instability criterion (7.11); they are identical if the Mackey-Glass compartment volume is interpreted as  $K = K_B Q^* / A Q_B^*$ . And, in fact, table 7.1 indicates that with this definition,  $K = 34.8 \text{ l(BTPS)}$ , close to the tissue volume of 39 l. Thus the Mackey-Glass instability criterion is quite close to that derived from the Grodins model, despite the fact that the models are not at all equivalent.

### Grodins controller, $v(p_C)$

The more realistic controller has the ventilation being a function of  $p_C$ . In this case we take

$$v = [1 + \gamma \{p_C(t - \tau) - a\}]_+, \quad (7.74)$$

and if we use the small  $\mu$  result (7.58), then it is obvious that the steady state is unconditionally stable. To find an instability criterion, we need to retain the delay kernel form (7.56). We write  $p_B = a + p$  as before, so that

$$\dot{p} \approx 1 + \bar{p} - p - \left[ 1 + \gamma \int_0^\infty p(t - \tau - s)k(s) ds \right]_+, \quad (7.75)$$

and for small perturbations about the equilibrium  $p = 0$ , then  $\bar{p} = 0$ , and solutions  $p \propto \exp(\sigma t)$  exist if

$$\sigma = -1 - \gamma \hat{k}(\sigma) e^{-\sigma \tau}, \quad (7.76)$$

where

$$\hat{k}(\sigma) = \int_0^\infty k(s) e^{-\sigma s} ds \quad (7.77)$$

is the Laplace transform of  $k(s)$ . For the exponential kernel (7.57),  $\sigma$  satisfies

$$\sigma = -1 - \frac{\gamma \mu}{\mu + \sigma} e^{-\sigma \tau}. \quad (7.78)$$

For small positive  $\gamma$ ,  $\text{Re } \sigma < 0$  and the steady state is stable; oscillatory instability occurs for  $\gamma > \gamma_c$ , where

$$\gamma_c = \frac{(\mu + 1)\omega}{\mu \sin \omega \tau}, \quad (7.79)$$

where

$$\tan \omega \tau = \frac{(\mu + 1)\omega}{\omega^2 - \mu}. \quad (7.80)$$

When  $\mu$  and  $\tau$  are both small, one can show that

$$\gamma_c \approx \frac{1}{\mu \tau}, \quad (7.81)$$

and this shows how stability is obtained in the limit  $\mu \rightarrow 0$ . It leaves unclear what the actual mechanism of instability is which causes Cheyne-Stokes respiration.

## 7.8 Notes and references

### Exercises

- 7.1 In respiratory physiology, what is meant by the *minute ventilation*? Describe the way in which respiration is controlled by the blood gas concentrations at the central and peripheral chemoreceptors.

The Mackey-Glass model is a one compartment model of respiratory control, and can be represented by the equations

$$K\dot{p} = M - p\dot{V},$$

$$\dot{V} = \dot{V}(p_\tau);$$

explain what the various terms represent, and their physiological interpretation.

Suppose that

$$\dot{V} = G[p - p_0]_+,$$

and that  $M = 200$  mm Hg l(BTPS)  $\text{min}^{-1}$ ,  $p_0 = 35$  mm Hg,  $K = 40$  l(BTPS),  $G = 2$  l(BTPS)  $\text{min}^{-1}$  mm Hg $^{-1}$ ,  $\tau = 0.2$  min. Show how to non-dimensionalise the equations to obtain the dimensionless form

$$\dot{p} = \alpha[1 - (1 + \mu p)v],$$

$$v = [p_1]_+,$$

and give the definitions of  $\alpha$  and  $\mu$ . Check that they are dimensionless, and find their values.

7.2 The original Mackey-Glass model was written in the form

$$\dot{p} = \lambda - \kappa p\dot{V},$$

$$\dot{V} = \frac{V_m p_\tau^n}{\theta^n + p_\tau^n}.$$

Mackey and Glass assumed normal steady state values of  $p = p^* = 40$  mm Hg,  $\dot{V} = V^* = 7$  l  $\text{min}^{-1}$ ,  $d\dot{V}/dp|_{p^*} = G^* = 4$  l  $\text{min}^{-1}$  mm Hg $^{-1}$  and also that  $\lambda = 6$  mm Hg  $\text{min}^{-1}$  and  $V_m = 80$  l  $\text{min}^{-1}$ . Use these to infer values of  $\kappa$ ,  $n$  and  $\theta$ . Are the values of  $\lambda$  and  $\kappa$  consistent with the values of  $M$  and  $K$  in question 7.1?

7.3 The Mackey-Glass model of question 7.1 is written in the form

$$\dot{p} = \alpha[1 - (1 + \mu p)v(p_1)],$$

where  $v$  is taken to be a monotone increasing positive function of its argument, and  $\alpha$  and  $\mu$  are positive constants.

Show that there is a unique positive steady state  $p^*$ .

By linearising about this steady state, show that the steady state is unstable if  $\text{Re } \sigma > 0$ , where

$$\sigma = -\beta - \gamma e^{-\sigma},$$

and  $\beta = \alpha\mu v(p^*)$ ,  $\gamma = \alpha(1 + \mu p^*)v'(p^*)$ .

Show that this equation has (two) real roots if and only if  $\gamma < 1$  and  $\beta < \ln(1/\gamma) - 1$ , and that these are both negative.

7.4 Picard's theorem states that a holomorphic function  $f(z)$  having an isolated essential singularity at  $z = z_0$  takes on every possible complex value in any neighbourhood of  $z_0$ , with at most one exception. Use this to show that the equation for  $\sigma$ ,

$$\sigma = -\beta - \gamma e^{-\sigma},$$

where  $\beta$  and  $\gamma$  are positive constants, has an infinite number of complex roots in a neighbourhood of  $\infty$ .

Show that if  $\sigma \rightarrow \infty$ , then also  $\operatorname{Re} \sigma \rightarrow -\infty$ .

Show that the complex roots vary continuously with  $\gamma$  (for example show that  $\partial\sigma/\partial\gamma$  exists for complex  $\sigma$ ).

Show that  $\operatorname{Re} \sigma < 0$  for all roots if  $\gamma$  is sufficiently small.

Deduce that instability occurs for  $\gamma > \gamma_c$ , where

$$\gamma_c = \frac{\Omega}{\sin \Omega},$$

and  $\Omega$  is the smallest (positive) root of

$$\tan \Omega = -\frac{\Omega}{\beta}.$$

Use **Maple** or some other graphical software to plot  $\gamma_c$  as a function of  $\beta$ .

7.5 The Haldane buffering relation between alveolar  $\text{CO}_2$  volume fraction  $F_{\text{ACO}_2}$  and arterial  $\text{CO}_2$  concentration  $C_{\text{aCO}_2}$  is given by the equation 3.1 of Grodins *et al.* (1967):

$$C_{\text{aCO}_2} = (\text{BHCO}_3)_b + 0.375[(\text{Hb}) - C_{\text{aHbO}_2}] + k\alpha_{\text{CO}_2}(B - 47)F_{\text{ACO}_2} \\ - [0.16 + 0.23(\text{Hb})] \left[ \log \left( \frac{C_{\text{aCO}_2} - k\alpha_{\text{CO}_2}(B - 47)F_{\text{ACO}_2}}{0.01(B - 47)F_{\text{ACO}_2}} \right) - 0.14 \right].$$

The arterial concentration of oxyhaemoglobin is given by the Grodins equations 3.2 — 3.6:

$$C_{\text{aHbO}_2} = (\text{Hb}) [1 - \exp\{-S(B - 47)F_{\text{AO}_2}\}]^2$$

(this is the oxygen dissociation curve exhibiting the Bohr effect),

$$S = 0.449(\text{pH}_a) - 0.101(\text{pH}_a)^2 + 0.0067(\text{pH}_a)^3 - 0.454,$$

$$(\text{pH}_a) = 9 - \log C_{\text{aH}^+},$$

and

$$C_{\text{aH}^+} = K' \left[ \frac{k\alpha_{\text{CO}_2}(B - 47)F_{\text{ACO}_2}}{C_{\text{aCO}_2} - k\alpha_{\text{CO}_2}(B - 47)F_{\text{ACO}_2}} \right],$$

$$C_{\text{aO}_2} = -k\alpha_{\text{O}_2}(B - 47)F_{\text{AO}_2} + C_{\text{aHbO}_2}.$$

Write  $C = C_{\text{aCO}_2}$ ,  $P = P_{\text{aCO}_2}$ , use (7.19) to relate  $P$  to  $F_{\text{aCO}_2}$ , and take the numerical values given by Grodins *et al.* (1967):

$$(\text{HbCO}_3)_b = 0.547 \text{ l(STPD) l}^{-1}, \quad (\text{Hb}) = 0.2 \text{ l(STPD) l}^{-1},$$

$$K' = 795 \text{ nm l}^{-1}, \quad \alpha_{\text{O}_2} = 0.024 \text{ l(STPD) l}^{-1},$$

values of  $k$  and  $\alpha_{\text{CO}_2}$  from table 7.1, and  $B = 760 \text{ mm Hg}$ , to show that

$$P = Q(C - \Sigma P) \exp[R(C - \Sigma P)],$$

and calculate the numerical values of  $Q$ ,  $R$  and  $\Sigma$ .

[Units of  $C$  and  $P$  are  $\text{l(STPD) l}^{-1}$  and  $\text{mm Hg}$ ; units of  $C_{\text{aH}^+}$  are  $\text{nm (nanomoles)}$ .]

7.6 Explain how the expressions for the delays given in (7.29) and (7.30) are derived from the equation of conservation of blood volume, indicating specifically how the blood vessel volumes  $V_{pQ}$  are related to the compartments of figure 7.4.

7.7 Use the equations (7.38), (7.49) and (7.50) to show that the steady state ventilation is given by the solution of the equation

$$V^* = \frac{V_0^2}{V^*} - V_1,$$

and give the definitions of  $V_0$  and  $V_1$ . Hence show that a unique positive steady state exists, and find typical values for  $V^*$  and  $P^*$  using parameter values (but not those for  $V^*$  and  $P^*$ !) from tables 7.1 and 7.3. How do ventilation and  $\text{CO}_2$  partial pressure vary with tissue metabolic  $\text{CO}_2$  production? Does this make sense?

7.8 A simplified version of the Grodins model describes  $\text{CO}_2$  partial pressures in arteries, veins, brain and tissues by the equations

$$\begin{aligned} K_L \dot{P}_{\text{aCO}_2} &= -\dot{V} P_{\text{aCO}_2} + 863 K_{\text{CO}_2} Q [P_{\text{vCO}_2} - P_{\text{aCO}_2}], \\ K_{\text{CO}_2} K_B \dot{P}_{\text{BCO}_2} &= MR_{\text{BCO}_2} + K_{\text{CO}_2} Q_B [P_{\text{aCO}_2} (t - \tau_{\text{aB}}) - P_{\text{BCO}_2}] \\ K_{\text{CO}_2} K_T \dot{P}_{\text{TCO}_2} &= MR_{\text{TCO}_2} + (Q - Q_B) K_{\text{CO}_2} [P_{\text{aCO}_2} (t - \tau_{\text{aT}}) - P_{\text{TCO}_2}], \end{aligned}$$

with the venous pressure being determined by

$$Q P_{\text{vCO}_2} = Q_B P_{\text{BCO}_2} (t - \tau_{\text{vB}}) + (Q - Q_B) P_{\text{TCO}_2} (t - \tau_{\text{vT}}).$$

Explain the meaning of the equations and their constituent terms.

Use values  $K_L = 3 \text{ l}$ ,  $V^* = 5 \text{ l min}^{-1}$ ,  $863 K_{\text{CO}_2} Q = 26 \text{ l min}^{-1}$ ,  $K_B = 1 \text{ l}$ ,  $Q = 6 \text{ l min}^{-1}$ ,  $Q_B = 0.75 \text{ l min}^{-1}$ ,  $K_T = 39 \text{ l}$ , to evaluate response time scales for arterial, brain and tissue  $\text{CO}_2$  partial pressures.

Deduce that for oscillations on a time scale of a minute, one can assume that the arterial pressure is in quasi-equilibrium, and that the tissue (and thus also venous) partial pressures are approximately constant.

Hence derive an approximate expression for  $P_{\text{aCO}_2}$  in terms of the ventilation  $\dot{V}$ .

7.9 Show that it is possible to ‘derive’ the Mackey-Glass equation (7.2) from the Grodins model (7.25), (7.26) and (7.27), assuming a central controller dependent on  $P_{\text{BCO}_2}$ , if  $\nu$  and  $\delta$  are small; the non-controlling delays  $\tau_{\text{aT}}$ ,  $\tau_{\text{vB}}$  and  $\tau_{\text{vT}}$  are small; and either  $s \ll 1$  and  $s \ll \Lambda$ , in which case the single compartment consists of the tissues, or  $\Lambda \ll 1$  and  $\Lambda \ll s$ , in which case the compartment is the lung.

Show that the tissue compartment version is consistent with the actual values of  $s$  and  $\Lambda$ , but that in this case the controlling time scale is the tissue scale (7 minutes), and instability is not realistically feasible.

7.10 Suppose that  $p_C$  satisfies the equation

$$\dot{p}_C = \mu(p_B - p_C),$$

where  $\mu \ll 1$  and  $p_B$  varies on a time scale of  $O(1)$ , and that the mean value  $\bar{p}_B$  is constant and well-defined as

$$\bar{p}_B = \lim_{t \rightarrow \infty} \frac{1}{t} \int_0^t p_B(s) ds.$$

Write down the exact solution for  $p_C$ .

Use the method of multiple scales (with times  $t$ ,  $\tau = \mu t$ ) to show that

$$p_C = \bar{p}_B + Ae^{-\tau} + O(\mu).$$

Show that this result is consistent with the exact solution in the particular case where  $p_B$  is periodic. [Use a Fourier series for  $p_B$ .]

7.11 Suppose that  $\sigma$  satisfies the transcendental equation

$$\sigma = -1 - \frac{\gamma\mu}{\mu + \sigma} e^{-\sigma\tau},$$

where  $\gamma$ ,  $\mu$  and  $\tau$  are positive.

Show that there are an infinite number of complex roots, at most two real roots, and that the complex roots accumulate at  $\infty$  with  $\text{Re } \sigma \rightarrow -\infty$ .

Show that a necessary condition for  $\text{Re } \sigma > 0$  is that  $\gamma > 1$ .

Show that  $\sigma \neq 0$  for positive  $\gamma$ .

Show that if  $\sigma = i\omega$ , then

$$\gamma = \gamma_c(\omega) = \frac{(\mu + 1)\omega}{\mu \sin \omega\tau}$$

where

$$\tan \omega\tau = \frac{(\mu + 1)\omega}{\omega^2 - \mu},$$

and deduce that there are an infinite number of values of  $\omega$  and  $\gamma$  which satisfy these relations.

Show that if  $\sqrt{\mu}\tau < \pi/2$ , then the positive roots  $\omega_n$ ,  $n = 0, 1, 2, \dots$  satisfy  $n\pi < \omega_n < (n + \frac{1}{2})\pi$ , and that  $\omega_n - n\pi$  decreases as  $n$  increases.

Deduce that oscillatory instability occurs for  $\gamma > \gamma_c(\omega_0)$ , and plot  $\gamma_c$  as a function of  $\mu$  (see figure 7.7).

Show that  $\gamma_c \rightarrow \frac{\pi}{2\tau}$  as  $\mu \rightarrow \infty$  and  $\gamma \approx \frac{1}{\mu\tau}$  if  $\mu$  and  $\tau$  are small.

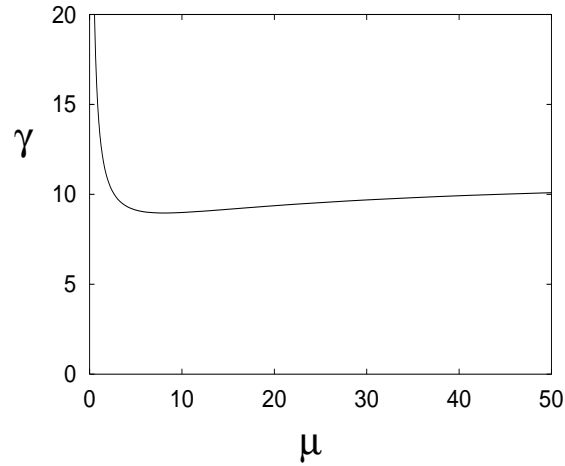

Figure 7.7: Critical  $\gamma$  as a function of  $\mu$  as given by (7.79) and (7.80) (with  $\omega\tau \in (0, \pi)$ ) for  $\tau = 0.15$ . The minimum  $\gamma$  is 8.962 at  $\mu = 8.045$ .

# Chapter 8

## Blood cell production

Of all the cells in the human body, some  $10^{14}$ , fully a quarter are blood cells. And of these, by far the most common are the red blood cells (RBC), also known as *reticulocytes* or *erythrocytes*. Circulating erythrocyte density in a healthy adult human is about  $5 \times 10^{12}$  cells  $l^{-1}$ . Just as the function of respiration is to supply oxygen to the body, the primary rôle of blood is to transport this oxygen to the tissues. In chapter 6, we described how the circulation of the blood was effected by the pump action of the heart, but we did not describe how oxygen itself is transported. In fact, oxygen is very poorly soluble in blood, and so the rôle of carrier is taken by the red blood cells, which contain the protein *haemoglobin*. Oxygen readily binds to haemoglobin, and in this way the red blood cells act as the oxygen transporters within the blood. Red blood cells also facilitate the transport of  $CO_2$ . They contain the enzyme *carbonic anhydrase*, which catalyses the reaction of  $CO_2$  with water to form hydrogen ions and bicarbonate ions, and in fact most of the  $CO_2$  transported in the blood does so by this means.

Although present in far fewer numbers, there are two other principal types of blood cells: platelets and white blood cells (WBC). Platelets (also called *thrombocytes*) are small cell fragments which are formed by the disintegration of parent cells called *megakaryocytes*. A typical circulating density is  $3 \times 10^{11}$  cells  $l^{-1}$ . They are instrumental in blood clotting, which is a fundamental causative mechanism in wound healing.

White blood cells, or *leukocytes*, come in six different forms, and provide different constituents of the immune system, which is concerned with the protection of the body from invasion by foreign organisms. They are present in far fewer numbers than platelets and red blood cells, a typical density of all white blood cell types being  $7 \times 10^9$  cells  $l^{-1}$ . The six different types of white blood cell are the *neutrophils*, the *eosinophils*, the *basophils*, the *monocytes*, the *lymphocytes*, and the *plasma cells*. The first three of these have a granular appearance, and thus are called *granulocytes*. The granulocytes and the monocytes protect the body against foreign organisms by means of *phagocytosis*: that is, by ingesting them. *T* lymphocytes and *B* lymphocytes, and the plasma cells, form important constituents of the immune system. Most of the circulating white blood cells are neutrophils (nearly two thirds) and lymphocytes



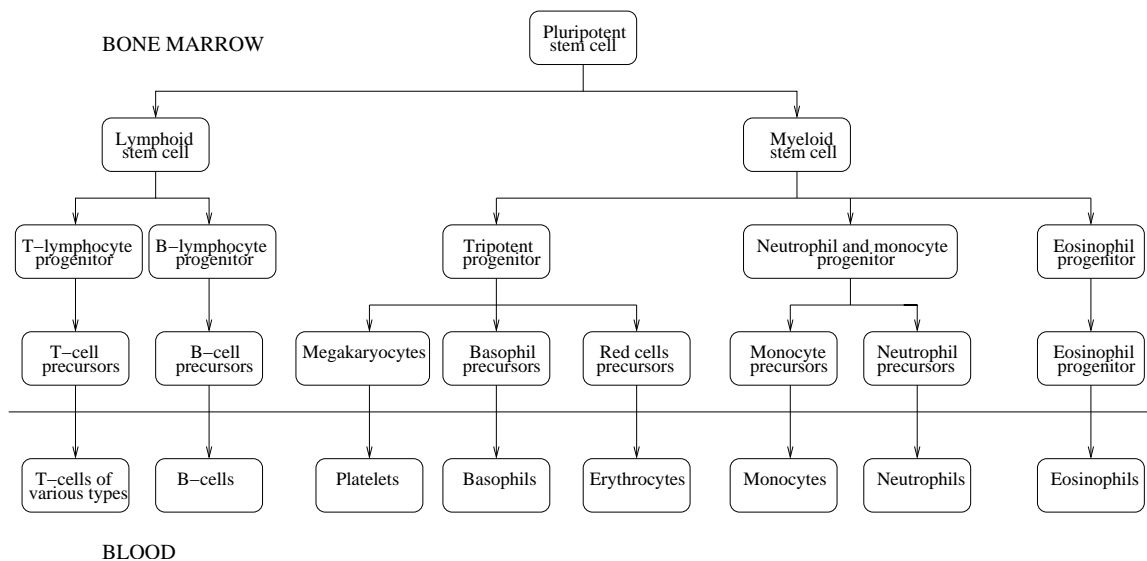

Figure 8.1: The cell lines of development of leukocytes, erythrocytes and platelets from a supposed parent pluripotential stem cell. There are many generations of differentiating cells (at least ten), and the process of development may take upwards of twenty days.

(nearly one third): the other types are present in smaller quantities in the blood.

## 8.1 Stem cells and their lineage

All of the various blood cell types are derived from primitive cells called *haematopoietic stem cells* (or pluripotent haematopoietic stem cells) which are located in the bone marrow. The different kinds of cells arise through a process of maturation which gives rise to a kind of family tree, such as that represented in figure 8.1. When a primitive stem cell differentiates down one of the descendant paths, we say that it is a committed stem cell. At the trunk (or, in fact, the stem) of the family tree, there is an initial divergence between the lymphoid and myeloid cell lines. The primitive lymphoid cells (called *blast* cells) migrate to the *lymph nodes* where they develop through a sequence of developmental stages until they form the various kinds of *T* and *B lymphocytes* of the immune system. The other developmental line is that of myeloid cells, which develop in the bone marrow, and which lead through an initial divergence between erythroblasts, megakaryoblasts and myeloblasts, to the eventual formation of (respectively) erythrocytes, platelets and the various forms of white blood cells, or leukocytes. The myeloid leukocytes are also called *myelocytes*, and comprise the granulocytes and monocytes. Generally speaking, there is a non-uniqueness of cell nomenclature.

The actual ‘reproduction’ process takes place as a consequence of cell progression through the cell cycle indicated in figure 8.2. Cells may exist in a ‘resting’ phase, called

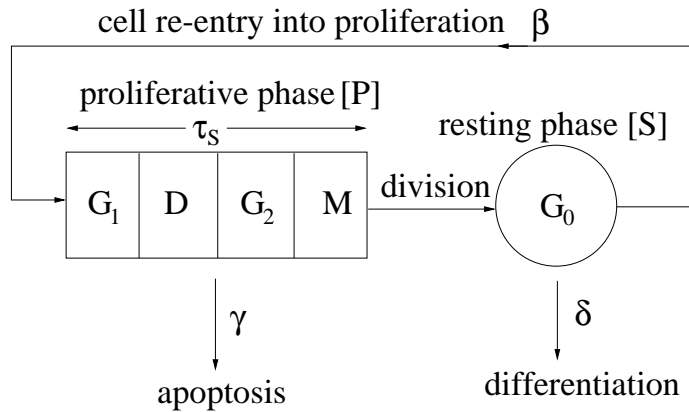

Figure 8.2: The cell cycle. The resting phase is denoted by  $G_0$ , and the proliferative phase includes sub-phases labelled  $G_1$ ,  $D$  (DNA synthesis),  $G_2$  and  $M$  (mitosis), the last of which culminates in division of the cell to form two new cells. These may be more mature cells, or may be copies of the original cell, the relative rates of differentiation and regeneration being presumably controlled by the numbers of extant cell types.

the  $G_0$  phase, in which they are quiescent. They may leave the resting phase and enter the proliferative phase, during which they go through a sequence of sub-phases, at the end of which cell division occurs (mitosis) and two new cells are produced. Cells may mature continuously, so that the divided cells are more ‘mature’ (differentiated) than the parent. (This cannot be entirely true for stem cells, presumably, otherwise they would be gradually depleted with time; although one view of the aging process is that it is simply due precisely to such a gradual depletion.) Cell division typically takes about two days, and this introduces a delay into the description of cell cycle control. Cells can also spontaneously die. This process is called *apoptosis*, and it provides a simple first order control on cell numbers.

As with other physiological systems, the number of blood cells in the body needs to be tightly controlled. Diseases occur when the cell numbers increase or decrease beyond certain bounds. For example, uncontrolled proliferation of white blood cells occurs in leukaemia. It is therefore reasonable to infer that the processes of the cell cycle are themselves controlled, although the signalling factors which enable this are not known. It is likely that control is exerted at several levels, and by several different hormones.

Peripheral control is also exercised on the process of differentiation. For example, the number of circulating red blood cells is directly related to blood oxygen concentration. If this falls too low, then a substance called *erythropoietin* is released, which stimulates increased production of reticulocytes, and thus eventually restores the circulating RBC level. As with other physiological controls, the response is delayed, so that the possibility of oscillation exists. Similar controls on WBC and platelet numbers are effected by *granulopoietin* and *thrombopoietin*, respectively.

## 8.2 Periodic haematopoietic diseases

There are a number of blood diseases in which oscillations in blood cell counts have been reported. The first four of those described below involve oscillations in all blood cell types. This is suggestive of an instability at the stem cell cycle level, and in the following sections, beginning in section 8.3, we introduce a family of models describing cell regulation, which are capable of producing oscillations. At the simplest level, these are delay differential equations, but when maturation stage is introduced as a separate independent variable, they become delay partial differential equations.

The last two diseases below, auto-immune haemolytic anaemia and cyclical thrombocytopenia, involve oscillations in one blood cell type, suggestive of an instability in the peripheral control process, and we will describe models of delay type which can describe these oscillations too. Here the delay is that involved in the differentiation process.

All of the oscillatory diseases which we describe have periods in the range upwards of 20 days. This suggests that the controlling time scale is that of differentiation, which may be of this order, rather than the shorter delay (2 days) induced by the cell cycling time. This will be consistent with the models we study.

### 8.2.1 Cyclical neutropenia

The appended *-penia* indicates a lack, thus neutropenia (or, more generally, leukopenia) is a disease in which neutrophils are abnormally low, due to low production rate in the bone marrow. In cyclical neutropenia, neutrophil counts rise and then fall to extremely low levels, with a fairly regular period of about 20 days. The other blood cell types also oscillate, although less regularly. The cause of the oscillations is thought to originate in the stem cell compartment, both because of this, and also because a cell density wave can be seen to propagate down the maturation sequence through myeloblasts, promyelocytes and myelocytes before being manifested in the circulation. Figure 8.3 shows blood cell counts from a patient with cyclical neutropenia.

### 8.2.2 Chronic myelogenous leukaemia

Leukaemia refers to the uncontrolled proliferation of white blood cells. There are two main types: lymphocytic and myelogenous, referring to the affected cell lineages. Chronic myelogenous leukaemia, often abbreviated as CML, is a form of leukaemia which eventually leads to premature release into the blood of excessive numbers of immature white blood cells. The disease is caused by a single genetic alteration in (probably) a single haematopoietic stem cell, which leads to proliferation of the abnormal cell lineage, and increased numbers of leukocytes in the circulation. There is a chronic phase, which with treatment can last for years, and in this chronic phase pronounced oscillations in the leukocyte population can occur (figure 8.4), with a

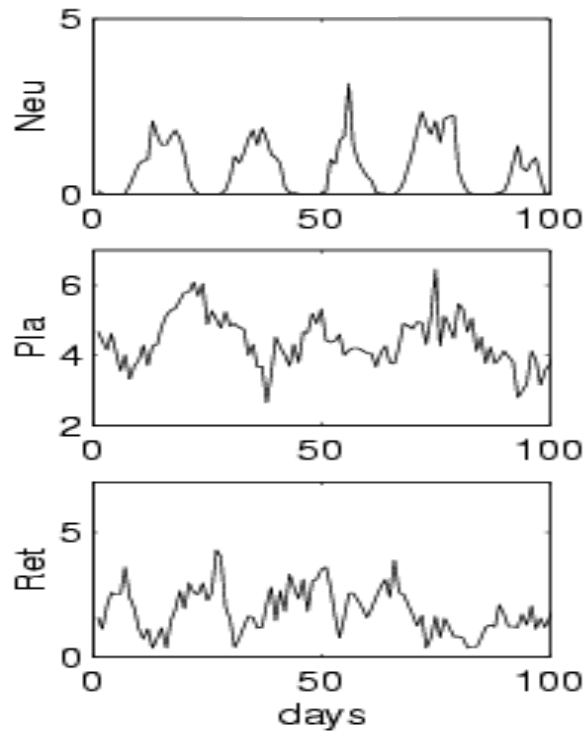

Figure 8.3: Neutrophil, platelet and reticulocyte counts for a patient with cyclical neutropenia. Units are: neutrophils,  $10^9$  cells  $l^{-1}$ ; platelets,  $10^{11}$  cells  $l^{-1}$ ; reticulocytes,  $10^{10}$  cells  $l^{-1}$ . Figure provided courtesy of Michael Mackey.

typical period of 60 days. Like cyclical neutropenia, other blood cell types also oscillate, but less regularly.

The chronic phase is eventually followed by an acute phase, during which abnormal cell density increases dramatically (known as blast crisis) and other cell mutations appear. The acute phase lasts months, and leads inevitably to death. Conventional treatments for CML include substances such as interferon- $\alpha$ , which essentially kill cells, but a much more promising (designed) drug which targets the enzyme action of the abnormal cells is STI571, and this appears to be much more successful in the early trials which have taken place.

### 8.2.3 Polycythemia vera

Polycythemia vera is similar to CML in that it is caused by a mutation of a single stem cell, which leads to increased proliferation of all the haematopoietic progenitor cells. Red blood cell counts may rise to 7 or  $8 \times 10^{12}$  cells  $l^{-1}$ , and the *haematocrit* (the percentage of blood consisting of cells) rises from its normal 40% to 60 or 70%. Blood volume also increases, leading to vascular engorgement, and the increased viscosity

tends to cause blocking of capillaries. At least in some cases, all three blood cell types can oscillate (figure 8.5), somewhat irregularly, with a period of about 20 days.

### 8.2.4 Aplastic anaemia

Anaemia means a deficiency of haemoglobin, either due to insufficient Hb concentration within red blood cells, or to too few red blood cells. Aplastic anaemia is caused by the lack of a functioning bone marrow, and can be caused by radiation damage, for example. Oscillations have been seen with a period of about 40 days (figure 8.6).

### 8.2.5 Auto-immune haemolytic anaemia

If the red blood cells are excessively fragile, they may rupture as they pass through the capillaries or the spleen. The normal resident lifetime of a red blood cell in the circulation is about 120 days. In haemolytic anaemia, even though production is normal, the life span of red blood cells is effectively shortened. Auto-immune haemolytic anaemia is a rare form of this anaemia in which oscillations in reticulocyte density have been reported, with a period of about 16 days.

### 8.2.6 Cyclic thrombocytopenia

Thrombocytopenia indicates a low level of thrombocytes, which refers to the cell lineage which gives rise to megakaryocytes and their fragmented progeny, platelets. People with this disease have a tendency to bleed internally from capillaries, so that the skin appears purple and blotchy, giving rise to the name *thrombocytopenic purpura*.

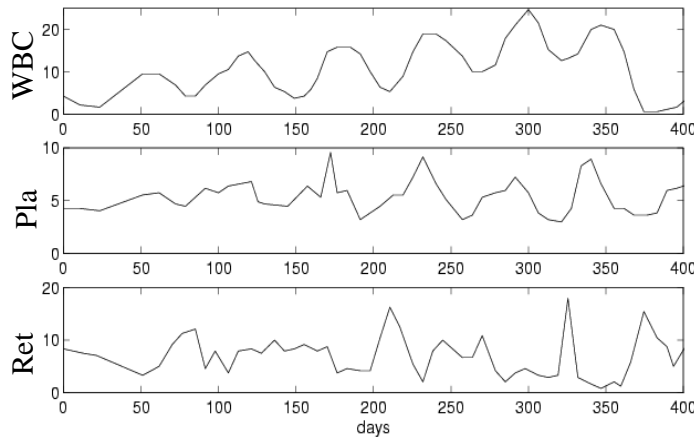

Figure 8.4: Leukocyte, platelet and reticulocyte counts for a patient with chronic myelogenous leukaemia. Units are: leukocytes,  $10^{10}$  cells  $l^{-1}$ ; platelets,  $10^{11}$  cells  $l^{-1}$ ; reticulocytes,  $10^{10}$  cells  $l^{-1}$ . Figure provided courtesy of Michael Mackey.

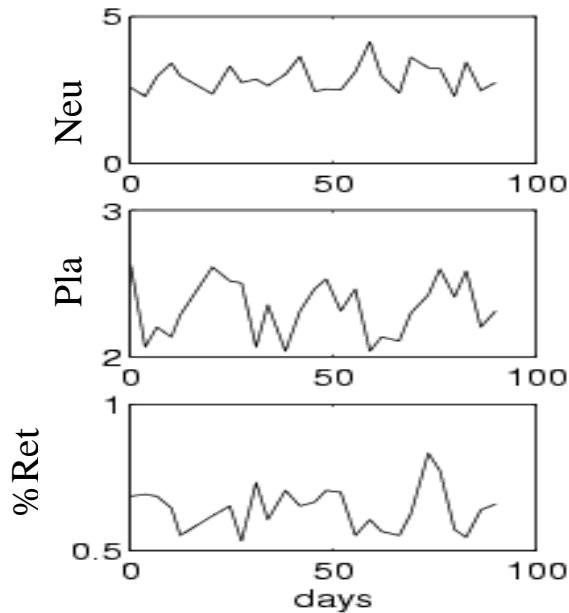

Figure 8.5: Neutrophil, platelet and reticulocyte counts for a patient with polycythemia vera. Units are: neutrophils,  $10^9$  cells  $l^{-1}$ ; platelets,  $10^{11}$  cells  $l^{-1}$ ; reticulocytes, in percentage (of all blood cells). Figure provided courtesy of Michael Mackey.

Cyclical thrombocytopenia, in which platelet counts oscillate with a period of between 20 and 40 days, has been reported. The oscillations are from normal to low levels.

### 8.3 Stem cell control models

The reproductive cycle of a cell was diagrammatically represented in figure 8.2. Reproduction of cells is controlled by various proteins called growth inducers. For example, IL-3 (interleukin-3) is a growth inducer for all stem cells, while other growth inducers are specific to different committed cell lines.

Differentiation of cells is controlled by another set of proteins called differentiation inducers, for example *erythropoietin* stimulates production of red blood cells, while a number of proteins stimulate white blood cell production; for example, G-CSF (granulocyte colony stimulating factor) stimulates production of granulocytes. Causative factors for increased CSF production are tissue injury or infection.

In this section we present a simple model for the growth inducer effected control of the cell cycle, and particularly for that of stem cells. We have in mind that an oscillatory instability in the controlled cell cycle may provide an explanation for the oscillations in some of the diseases described above, such as cyclical neutropenia and chronic myelogenous leukaemia.

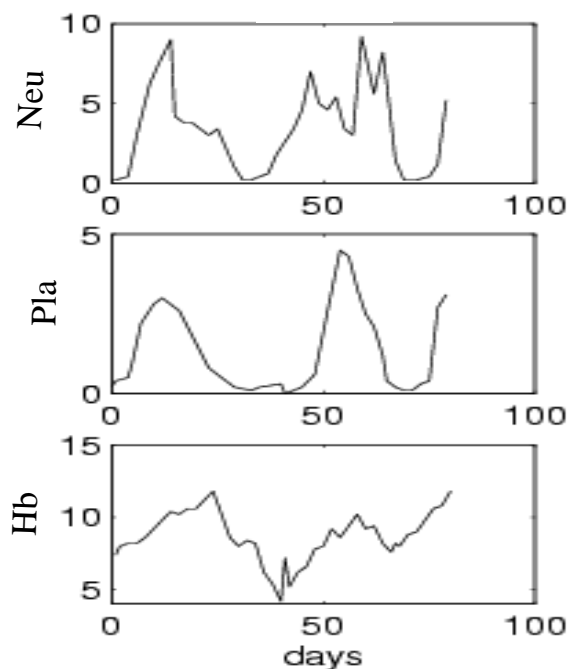

Figure 8.6: Neutrophil, platelet and haemoglobin counts for a patient with aplastic anaemia. Units are: neutrophils,  $10^9$  cells  $l^{-1}$ ; platelets,  $10^{11}$  cells  $l^{-1}$ ; Hb, g  $dl^{-1}$ . Figure provided courtesy of Michael Mackey.

### 8.3.1 The $G_0$ model

The model is based on the diagram in figure 8.2. We let  $N$  denote the density of cells in the resting phase, and  $P$  denote the density of cells in the proliferative phase. We suppose the recruitment rate from the resting phase is proportional to  $N$ , that cell apoptosis occurs in the proliferative phase proportionally to  $P$ , and that cells are lost by differentiation from the resting phase at a rate proportional to  $N$ . As indicated in figure 8.2, the coefficients of proportionality are taken to be  $\beta$ ,  $\gamma$  and  $\delta$ , respectively. Conservation equations for the cell densities are then given by

$$\begin{aligned}\dot{P} &= -\gamma P + \beta(N)N - e^{-\gamma\tau}\beta(N_\tau)N_\tau, \\ \dot{N} &= -\beta(N)N - \delta N + 2e^{-\gamma\tau}\beta(N_\tau)N_\tau,\end{aligned}\tag{8.1}$$

where  $N_\tau = N(t-\tau)$ . The term  $e^{-\gamma\tau}\beta(N_\tau)N_\tau$  represents the flux from the proliferative phase to the resting phase. It is equal to the flux recruited from the resting phase, with allowance made for the time  $\tau$  spent in the proliferative phase, together with the exponential wastage factor due to apoptosis. The extra factor 2 in the equation for  $N$  arises from the fact of cell division on mitosis.

In these equations, we take  $\delta$  and  $\gamma$  to be constant, but we allow the specific recruitment rate  $\beta$  to depend on  $N$ , to represent the effect of growth inducer control

of proliferation, which is assumed to depend on the total number of resting phase cells. Other assumptions are equally possible, for example that control is effected by the proliferative phase density.

$\beta$  should be a decreasing function of  $N$ , and we take it to be a Hill function

$$\beta = \frac{\beta_0 \theta^n}{\theta^n + N^n}. \quad (8.2)$$

Note that in (8.1), the equation for  $P$  uncouples from that for  $N$ , so that we need consider only the equation for  $N$ . We non-dimensionalise it by scaling  $N \sim \theta$  and  $t \sim \tau$ . We then find the dimensionless equation for  $N$  in the form

$$\dot{N} = g(N_1) - g(N) + \varepsilon[\mu g(N_1) - N], \quad (8.3)$$

where

$$g(N) = \frac{bN}{1 + N^n}, \quad (8.4)$$

and the parameters are given by

$$b = \beta\tau, \quad \varepsilon = \delta\tau, \quad \mu = \frac{2e^{-\gamma\tau} - 1}{\delta\tau}. \quad (8.5)$$

We use typical values

$$\begin{aligned} \delta &= 0.05 \text{ d}^{-1}, \quad \beta_0 = 1.77 \text{ d}^{-1}, \quad \tau = 2.2 \text{ d}, \\ n &= 3, \quad \theta = 2.3 \times 10^3 \text{ cells } \mu\text{l}^{-1}, \quad \gamma = 0.2 \text{ d}^{-1}, \end{aligned} \quad (8.6)$$

to find

$$b \approx 3.9, \quad \mu \approx 2.6, \quad \varepsilon \approx 0.11. \quad (8.7)$$

The definition of the parameter  $\mu$  appears contorted, but it is in fact a natural one. We need  $\mu > 0$  in order that a steady cell population is viable, and we need  $\mu = O(1)$  in order that this steady state be of  $O(1)$ , which we need in order that the control by the Hill function for  $\beta$  be effective. Essentially, having  $\mu = O(1)$  allows the net gain of the resting cell population through proliferation to balance the loss to differentiation.

Provided  $\mu b > 1$ , there is a unique steady state for  $N$ . To assess its stability, we denote the steady state as  $N^*$ , and write  $N = N^* + u$ . Substituting this into the equation (8.3) and linearising, we derive the linear equation for  $u$ :

$$\dot{u} = g'[u_1 - u] + \varepsilon[\mu g' u_1 - u], \quad (8.8)$$

where  $g' = g'(N^*)$ . This has solutions  $u = \exp(\sigma t)$  providing

$$\sigma = -\alpha - \Gamma e^{-\sigma}, \quad (8.9)$$

where  $\alpha$  and  $\Gamma$  are defined by

$$\alpha = g' + \varepsilon, \quad \Gamma = -(1 + \varepsilon\mu)g'. \quad (8.10)$$



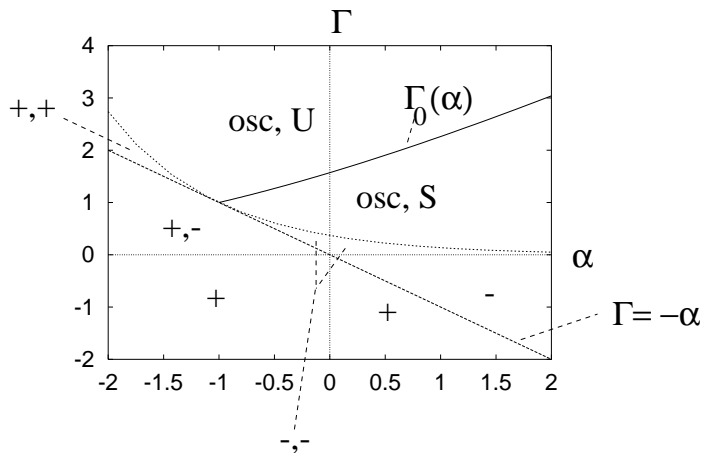

Figure 8.7: Stability map for red blood cell model. (This is the same map as that shown in figure 6.11.) The plus and minus signs indicate the sign of real values of the growth rate  $\sigma$ , when these exist.

(8.9) is an equation we have seen before, in chapter 6. Figure 8.7 shows the stability map in terms of the parameters  $\Gamma$  and  $\alpha$ . For the present case, we have that  $\Gamma + \alpha = \varepsilon(1 - \mu g')$ , and this is positive. (This follows from consideration of the graph of  $\mu g(N) - N$  if  $\mu b > 1$ .) Therefore the steady state is unstable if  $\Gamma > \Gamma_0(\alpha)$  (if  $\alpha > -1$  or if  $\alpha < -1$ ). Consulting the definitions of  $\Gamma$  and  $\alpha$ , we see that instability requires  $g' < 0$ , and (approximately, using the fact that  $\varepsilon$  is small)

$$g' < -1 - \frac{2}{3}\varepsilon(\mu - \frac{1}{2}), \quad (8.11)$$

where we use the fact that  $\Gamma'(-1) = \frac{1}{2}$ .

For small  $\varepsilon$ , the instability criterion is thus essentially that  $g'(N^*) < -1$ . Since  $g$  is

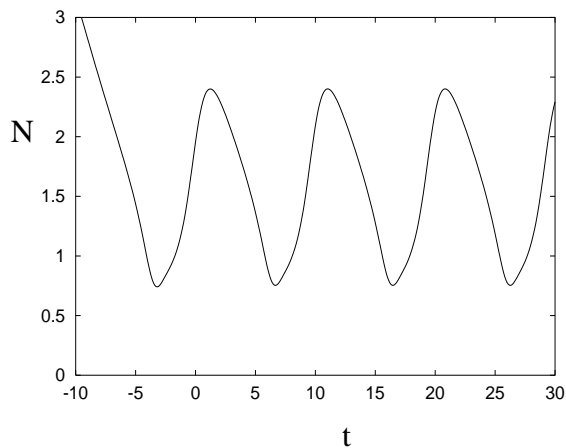

Figure 8.8: Solution of (8.3) with  $\varepsilon = 0.11$ ,  $b = 3.9$  and  $\mu = 1.2$ .

a unimodal function, this requires firstly that the most negative slope is less than  $-1$ , and then that  $N^*$  lies within the interval where  $g' < -1$ . Since  $g(N^*) = N^*/\mu$ , this is equivalent to  $\mu$  lying within a finite interval  $(\mu_-, \mu_+)$ . For the function  $g$  defined by (8.4), the criterion for a minimum slope less than  $-1$  is that

$$b > b_c = \frac{4n}{(n-1)^2}, \quad (8.12)$$

( $b_c = 3$  for  $n = 3$ ), and then the instability interval endpoints are

$$\mu_{\pm} = \frac{1}{2}(n-1) \left[ 1 \pm \left( 1 - \frac{b_c}{b} \right)^{1/2} \right]; \quad (8.13)$$

for  $n = 3$ ,  $b_c = 3$  and  $b = 3.9$ , we have  $\mu_- \approx 0.52$ ,  $\mu_+ \approx 1.48$ . Figure 8.8 shows the oscillations which result when  $\mu = 1.2$  within the instability interval.

### 8.3.2 Relaxation oscillations

One of the interesting features of many of the oscillations discussed previously is that they have relatively long periods, compared with the delay of 2 days in the cell cycle time. The reason for this is that the controlling time scale for the oscillations is the maturation time  $1/\delta \approx 20$  days, which is much longer than the cell cycle time. Indeed, we see from figure 8.8 that the dimensionless period is about 10, i. e., of  $O(1/\varepsilon)$ , which is dimensionally of  $O(1/\delta)$ . We can analyse these oscillations on the assumption that  $\varepsilon$  is small, and they then take the form of relaxation oscillations (albeit in an infinite dimensional system). We define a slow time variable

$$T = \varepsilon t, \quad (8.14)$$

so that the equation (8.3) becomes

$$N' = \frac{[g(N_\varepsilon) - g(N)]}{\varepsilon} + \mu g(N_\varepsilon) - N, \quad (8.15)$$

where  $N_\varepsilon = N(T - \varepsilon)$  and  $N' = dN/dT$ . The point is, that if  $N$  varies on the slow time scale  $T$ , then the delayed term can be Taylor expanded about  $T$ , thus yielding a first order differential equation for  $N$ . Carrying out the approximation, we find

$$\frac{dN}{dT} \approx \frac{\mu g(N) - N}{1 + g'(N)}, \quad (8.16)$$

and this describes evolution on a ‘slow manifold’ so long as  $g'(N) \neq -1$ . In the case where the steady state is unstable, that is,  $\mu_- < \mu < \mu_+$ , let  $N_{\pm}$  denote the intersections of  $N/\mu_{\pm}$  with  $g(N)$  (see figure 8.9); then when  $N < N_-$ ,  $N$  increases until it reaches  $N_-$ ; when  $N > N_+$ , it decreases until it reaches  $N_-$ . In either case, the

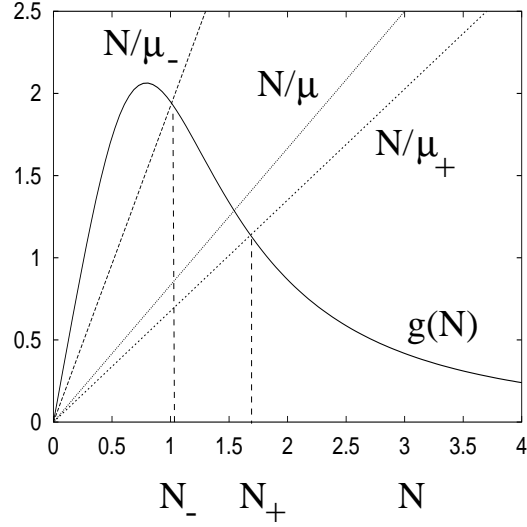

Figure 8.9: Graphs of  $g(N)$  and  $N/\mu$  for  $b = 3.9$ ,  $n = 3$ , and  $\mu = 1.2$  in the range  $(\mu_-, \mu_+) = (0.52, 1.48)$ . Also shown are graphs of  $N/\mu_-$  and  $N/\mu_+$ .

slowly varying approximation must break down, and there occurs a rapid transition, where  $N$  jumps on the  $t$  time scale. In this transition phase,  $N$  approximately satisfies

$$\frac{dN}{dt} = g(N_1) - g(N). \quad (8.17)$$

If a relaxation oscillation occurs, then we must have  $N$  tending to a constant as  $t \rightarrow \pm\infty$ , and direct integration of (8.17) indicates that in that case we must have

$$[N + g(N)]_{-\infty}^{\infty} = 0. \quad (8.18)$$

Numerical integration of (8.17) appears to confirm that indeed  $N$  tends to a constant as  $t \rightarrow \infty$ . Thus the relaxation oscillation traces out the path shown in figure 8.10, jumping rapidly from  $N_-$  up to  $N_U$ , slowly decreasing to  $N_+$ , jumping rapidly down to  $N_L$ , and then slowly increasing back up to  $N_-$ .

An approximation for the period is then determined by the time it takes to traverse the slow parts of the solution, and this is given (dimensionlessly) by  $P = P_0/\varepsilon$ , where

$$P_0 = \int_{N_+}^{N_U} \left( \frac{1 + g'}{N - \mu g} \right) dN + \int_{N_L}^{N_-} \left( \frac{1 + g'}{\mu g - N} \right) dN. \quad (8.19)$$

In dimensional terms, the period is thus  $P_0/\delta$ , and is directly proportional to the maturation time.

An instructive analogue follows by writing

$$\begin{aligned} v &= g(N_\varepsilon) + \varepsilon[\mu g(N_\varepsilon) - N], \\ \hat{v} &= \frac{g(N) - g(N_\varepsilon)}{\varepsilon}, \end{aligned} \quad (8.20)$$

when the functional differential equation (8.15) takes the form

$$\begin{aligned}\varepsilon N' &= v - g(N), \\ N' + \hat{v} &= \mu g(N) - N - \varepsilon \mu \hat{v}.\end{aligned}\tag{8.21}$$

With the single alteration that we take  $\hat{v} = v'$ , (8.21) forms a pair of ordinary differential equations whose oscillatory solutions have exactly the same form as those of the delay equation.

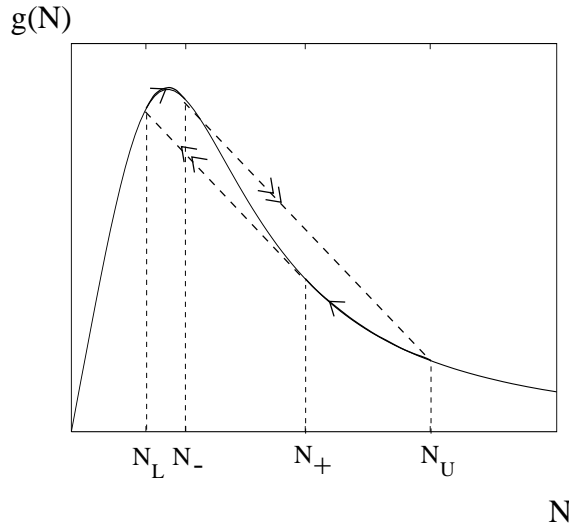

Figure 8.10: Phase diagram of the relaxation oscillations of (8.3).  $g(N)$  is plotted for  $b = 5$ ,  $n = 3$ .

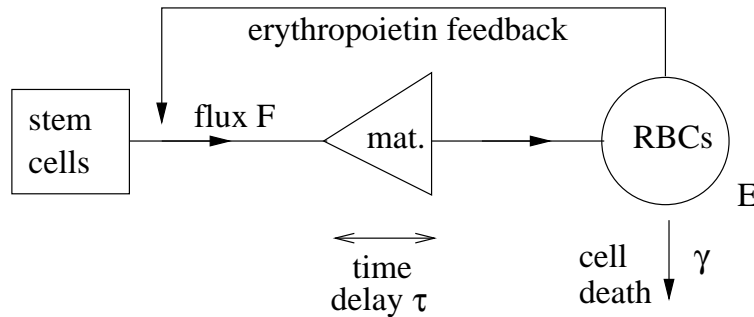

Figure 8.11: A schematic representation of erythropoietin feedback control of red blood cell production. The flux of cells  $F$  from the committed proerythroblasts is taken to depend on the RBC density  $E$ , with  $F(E)$  being a decreasing function. The delay  $\tau$  in the process of differentiation causes the flux delivered to the blood to depend on the value of  $E(t - \tau)$ .

## 8.4 Peripheral blood cell control models

Now we turn to a model which describes the peripheral control of red blood cell production by the hormone erythropoietin. Diagrammatically, the model is illustrated in figure 8.11. We denote the number of circulating red blood cells by  $E(t)$ , with units of cells  $\mu\text{l}^{-1}$ . The number of circulating RBCs directly affects the quantity of oxygen in the blood, and this controls the release of the hormone erythropoietin, which, we suppose, affects the flux  $F$  of RBCs released into the blood, both through the rate of commitment of pluripotential stem cells to the erythroid line, and by the rate of maturation of the cell lineage. Because of the time  $\tau$  which development of the mature blood cells takes, the flux  $F$  is in fact a function of the delayed erythrocyte density,  $E_\tau \equiv E(t - \tau)$ . If we suppose that blood cells die as a simple first order decay process<sup>1</sup> with delay constant  $\gamma$ , then a model for  $E$  is the first order differential delay equation

$$\frac{dE}{dt} = F[E_\tau] - \gamma E, \quad (8.22)$$

where we take  $F$  to be a monotonically decreasing function. To be specific, let us suppose that  $F$  is given by the Hill function

$$F(E) = \frac{F_0 \theta^n}{\theta^n + E^n}. \quad (8.23)$$

We non-dimensionalise the equation by scaling  $E \sim \theta$ ,  $t \sim \tau$ , so that the dimensionless version of (8.22) can be written as

$$\dot{\xi} = \rho f(\xi_1) - \alpha \xi, \quad f(\xi) = \frac{1}{1 + \xi^n}, \quad (8.24)$$

where  $\xi_1 = \xi(t - 1)$ , and

$$\alpha = \gamma\tau, \quad \rho = \frac{F_0\tau}{\theta}. \quad (8.25)$$

Typical estimated values of the parameters are  $\gamma = 2.3 \times 10^{-2} \text{ d}^{-1}$  (i. e.,  $\text{day}^{-1}$ ),  $F_0 = 10^6 \text{ cells } \mu\text{l}^{-1} \text{ d}^{-1}$ ,  $n = 8$ ,  $\theta = 3.5 \times 10^6 \text{ cells } \mu\text{l}^{-1}$ ,  $\tau = 6 \text{ d}$ . With these values, we find  $\rho \approx 1.7$ ,  $\alpha \approx 0.14$ . The equation for  $\xi$  has a unique steady state  $\xi^*$  (indeed this is evidently the case for any decreasing function  $f(\xi)$ ), and its stability is determined by linearisation about the steady state. We write  $\xi = \xi^* + \tilde{\xi}$ , linearise, and then solutions of the resulting linear equation are  $\exp(\sigma t)$ , where

$$\sigma = -\alpha - \Gamma e^{-\sigma}, \quad (8.26)$$

and

$$\Gamma = \rho |f'(\xi^*)|. \quad (8.27)$$

Again, the stability is described by figure 8.7. For positive  $\Gamma$  and  $\alpha$ , as here, the steady state loses stability in a Hopf bifurcation for  $\Gamma > \Gamma_0(\alpha)$ . For small values of

---

<sup>1</sup>This is an unrealistic simplification, since in reality red blood cells have a finite lifetime of about 120 days.

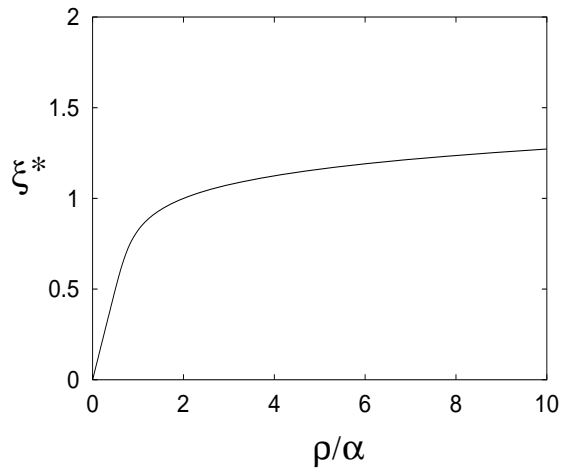

Figure 8.12: Variation of  $\xi^*$  with  $\rho/\alpha$ .

$\alpha$ , instability occurs approximately if  $\Gamma > \Gamma_0(0) = \pi/2$ , and the resulting blood cell population oscillates periodically. The frequency is approximately  $\pi/2$ , so that the dimensionless period is  $\approx 4$ , and the dimensional period is  $\approx 4\tau$ , or about 24 days with the values suggested here.

To apply this model to haemolytic anaemia, we would propose an increased value of  $\gamma$ , representing a shortened life span for red blood cells in the circulation. Other things being equal, increasing  $\gamma$  simply has the effect of increasing  $\alpha$ ; however, since  $\alpha$  is small, the instability criterion remains essentially the same,  $\Gamma \gtrsim \pi/2$ . In addition, changing  $\alpha$  has a dramatic effect on  $\Gamma$  through the variation of the steady state  $\xi^*$  (and thus  $|f'(\xi^*)|$ ). The steady state is given by  $\xi^*(1 + \xi^{*n}) = \rho/\alpha$ , and thus  $\xi^*$  is a monotonically increasing function of  $\rho/\alpha$ , as shown in figure 8.12. Consultation of

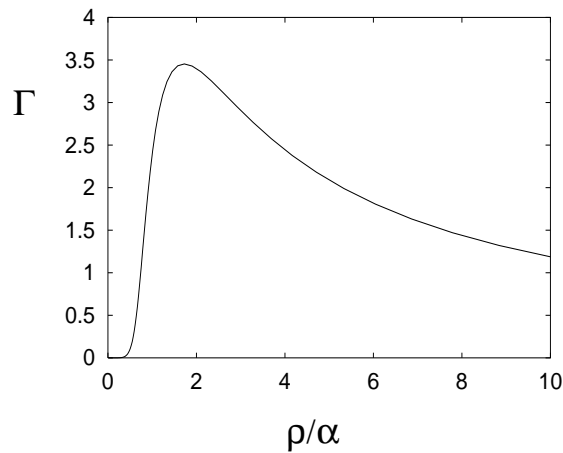

Figure 8.13: Variation of  $\Gamma$  with  $\rho/\alpha$ .

the graphs of  $\rho f(\xi)$  and  $\alpha\xi$  shows that  $\Gamma$  is a humped function of  $\alpha$ , as shown in figure 8.13. Further, because  $n$  is quite large, we see that when  $\xi^* < 1$ , then  $\xi^* \approx \rho/\alpha$ , and this must be when  $\alpha \gtrsim \rho$ ; conversely  $\xi^* \approx (\rho/\alpha)^{1/(n+1)}$  when  $\alpha \lesssim \rho$ . In particular, the maximum of  $\Gamma$  as a function of  $\alpha$  is when  $\alpha \sim \rho$ . Since our estimate for  $\rho/\alpha$  is approximately 12, it seems we can suppose always that  $\alpha < \rho$ , and thus that  $\Gamma$  increases monotonically as  $\alpha$  increases. Precisely, we find  $\Gamma = \alpha n \left[ 1 - \frac{\alpha \xi^*}{\rho} \right]$ , and using the approximation for  $\alpha < \rho$  with  $n$  large, we have

$$\Gamma \approx \alpha n; \quad (8.28)$$

thus an approximate instability criterion is

$$\alpha \gtrsim \frac{\pi}{2n}; \quad (8.29)$$

with the values we have used, this yields  $\alpha \gtrsim 0.2$ . Thus in this case, instability and consequent oscillations set in for a mild (50%) increase in the the blood cell removal rate  $\gamma$ . In principal, a sufficient increase of  $\gamma$  would re-stabilise the equilibrium, but this is not feasible in practice.

## 8.5 Maturation and delay

It is evident in the models we have studied so far that cell maturation, from committed stem cells through blast cells, colony forming units to fully mature blood cells, is an important constituent of the cell forming process. Since there are many different types of cells involved in maturation, it is natural to develop models which consider maturation stage as an independent variable, as well as age through the cell cycle, and time. Thus we generalise the  $G_0$  model of the cell cycle as indicated in figure 8.14, by letting the density of proliferative cells  $p$  and the density of resting phase cells  $n$  be functions of time  $t$ , maturation  $m$  and age  $a$ . The units of time are days (d), and we also measure age as a time, but we allow the units of maturation (mat) to be independent; for example, one might want to use cell generation number as a measure of maturation, and it is generally more flexible not to assume maturation is necessarily measured as a time.

We take age  $a$  to be measured from the beginning of the cell cycle, which is taken to be of duration  $\tau$ . Then for  $p$ , we have  $0 < a < \tau$ , while for  $n$ ,  $\tau < a < \infty$  (or one could have a maximum resting phase time). Maturation should proceed to a finite maximum, say  $m = m_F$ , when the mature cells are released into the blood. The total number of cells in a particular lineage is thus  $\int_0^{m_F} \int_0^\tau p(t, m, a) da dm$  in the proliferative phase, and  $\int_0^{m_F} \int_\tau^\infty n(t, m, a) da dm$  in the resting phase. This still assumes a single cell line.<sup>2</sup> The units of both  $p$  and  $n$  are cells age<sup>-1</sup> mat<sup>-1</sup>.

---

<sup>2</sup>In reality we should have cell densities  $p_i$  and  $n_i$ , where  $i$  labels the committed cell type.

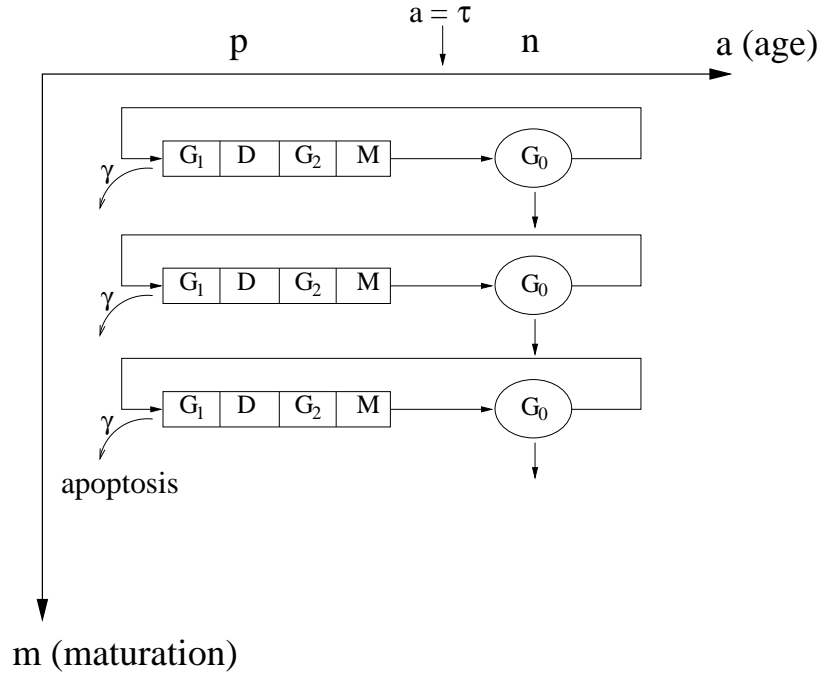

Figure 8.14: A schematic illustration of cell maturation and proliferation.

A particular conceptual difficulty concerns the primitive (uncommitted) stem cells at  $m = 0$ . We think of the stem cell pool as consisting of a finite number of cells, and these must then be described separately from  $p$  and  $n$ . We denote the proliferative and resting cell densities at  $m = 0$  as  $p_0(t, a)$  and  $n(t, a)$ , with units of cells  $\text{age}^{-1}$ .

Conservation laws for  $p$  and  $n$  follow from first principles, in a similar way to other age dependent population models, except that here there are two age-like variables. Conservation of proliferative cells implies

$$\frac{\partial p}{\partial t} + \frac{\partial p}{\partial a} + \frac{\partial(Vp)}{\partial m} = -\gamma p, \quad (8.30)$$

where  $V$  is the maturation rate, assumed positive, with units of  $\text{mat d}^{-1}$  (maturation units per day), and  $\gamma$  is the specific rate of apoptosis, assumed constant. We suppose (8.30) applies during the cell cycle of length  $\tau$  (which might depend on  $m$ ), thus for  $0 < a < \tau$ ; then for  $a > \tau$ , the cells in the resting phase satisfy the equation

$$\frac{\partial n}{\partial t} + \frac{\partial n}{\partial a} + \frac{\partial(Vn)}{\partial m} = -Rn, \quad (8.31)$$

which differs from (8.30) by the rate of recruitment  $R$  (units:  $\text{d}^{-1}$ ) back to the proliferative phase; cell mortality is taken to be zero in the resting phase. Equation (8.31) applies for  $a > \tau$ .

At the end of the cell cycle,  $a = \tau$ , we apply a boundary condition describing the conversion of  $p$  to  $n$ . This simply represents the fact of cell division on mitosis:

$$n(t, m, \tau) = 2p(t, m, \tau). \quad (8.32)$$



The analogue of the renewal equation describing birth in age-structured population models is the recruitment equation:

$$p(t, m, 0) = RN(t, m), \quad (8.33)$$

where  $N$  is the total cell density (with respect to  $m$  only) in the resting phase,

$$N = \int_{\tau}^{\infty} n da. \quad (8.34)$$

This follows from the basic integral conservation law for  $p$ ; when integrated over  $a$ , it is seen that the influx to  $p$  at the beginning of the cell cycle is just  $p(t, m, 0)$ .

If  $R > 0$  everywhere, it is reasonable to suppose that  $n \rightarrow 0$  as  $a \rightarrow \infty$ , and then integration of (8.31) with respect to  $a$  from  $\tau$  to  $\infty$  yields

$$\frac{\partial N}{\partial t} + \frac{\partial(VN)}{\partial m} = -RN + 2p(t, m, \tau). \quad (8.35)$$

Next we solve (8.30) for  $p$ , using the recruitment equation as the initial condition at  $a = 0$ . We parameterise this as

$$t = s, \quad m = \mu, \quad a = 0, \quad p = R(s, \mu)N(s, \mu), \quad (8.36)$$

valid for  $s, \mu > 0$ . These form the initial data for the characteristic equations for (8.30),

$$\dot{a} = 1, \quad \dot{m} = V, \quad \dot{p} = -(\gamma + V')p, \quad (8.37)$$

where  $V' = \partial V/\partial m$ ; to be specific, we will assume  $V = V(m)$ , so that  $V'(m) = dV/dm$ . The solution of the characteristic equations is

$$\begin{aligned} a &= t - s, \quad \int_{\mu}^m \frac{d\rho}{V(\rho)} = t - s, \\ p &= R(s, \mu)N(s, \mu) \exp \left[ - \int_s^t [\gamma + V'(m)] dt \right]. \end{aligned} \quad (8.38)$$

Now define a function  $\nu(m, a)$  by

$$\int_{\nu}^m \frac{d\rho}{V(\rho)} = a. \quad (8.39)$$

Then  $a = t - s$ ,  $\mu = \nu(m, a)$ . Also  $dt = dm/V(m)$  on a characteristic, thus for  $t > a$  (and also  $\nu > 0$ ),

$$p(t, m, a) = R[t-a, \nu(m, a)]N[t-a, \nu(m, a)] \exp \left[ - \int_{\nu(m, a)}^m \{ \gamma + V'(\rho) \} \frac{d\rho}{V(\rho)} \right]; \quad (8.40)$$

simplifying and putting  $a = \tau$ , we have

$$p(t, m, \tau) = R[t-\tau, \nu(m, \tau)]N[t-\tau, \nu(m, \tau)] \exp \left[ - \int_{\nu(m, \tau)}^m \frac{\gamma d\rho}{V(\rho)} \right] \frac{V[\nu(m, \tau)]}{V(m)}, \quad (8.41)$$

for  $t > \tau$  and  $\nu > 0$ . Finally, (8.35) becomes

$$\begin{aligned} \frac{\partial N}{\partial t} + \frac{\partial}{\partial m}(VN) &= -RN \\ &+ 2R[t - \tau, \nu(m, \tau)]N[t - \tau, \nu(m, \tau)] \exp \left[ - \int_{\nu(m, \tau)}^m \frac{\gamma d\rho}{V(\rho)} \right] \frac{V[\nu(m, \tau)]}{V(m)}. \end{aligned} \quad (8.42)$$

Note that

$$\int_{\nu(m, \tau)}^m \frac{d\rho}{V(\rho)} \equiv \tau. \quad (8.43)$$

It is convenient to define a modified maturation variable  $\xi$  by

$$\xi = \int_0^m \frac{d\rho}{V(\rho)}; \quad (8.44)$$

$\xi$  has units of time, and indeed it is equal to the elapsed time during maturation. Note that  $\nu > 0$  if  $\xi > \tau$ . The lower limit can be chosen for convenience, and allows us to fix  $\xi$  at some reference point; here we choose this to be the initial maturation stage (note that this cannot be done if  $V(0) = 0$ ). Now if

$$F(m) \equiv f(\xi), \quad (8.45)$$

then we find

$$F[\nu(m, \tau)] = f(\xi - \tau). \quad (8.46)$$

We change variable from  $m$  to  $\xi$ , and define

$$\begin{aligned} v(\xi) &\equiv V(m), \\ M &\equiv NV \end{aligned} \quad (8.47)$$

(note that  $M d\xi = N dm$ , so that  $M$  is cell density in terms of the variable  $\xi$ ; the units of  $M$  are cells  $d^{-1}$ ). After a little manipulation, we find

$$\frac{\partial M}{\partial t} + \frac{\partial M}{\partial \xi} = -RM + 2e^{-\gamma\tau} R_{\tau, \tau} M_{\tau, \tau}, \quad (8.48)$$

where

$$R_{\tau, \tau} = R[t - \tau, \xi - \tau], \quad M_{\tau, \tau} = M[t - \tau, \xi - \tau], \quad (8.49)$$

and we write  $M$  and  $R$  as functions of  $\xi$  and  $t$  rather than  $m$  and  $t$ .

This equation applies if  $t > \tau$  and  $\xi > \tau$ . To complete the specification of the equation for  $M$ , we have to consider initial conditions at  $t = 0$ , and the rate of committal of the pluripotential stem cell population at  $m = 0$ . If we suppose that

$$p = p_I(\xi, a) \quad \text{at} \quad t = 0, \quad (8.50)$$

then one can show (cf. question 8.8) that  $M$  satisfies

$$\frac{\partial M}{\partial t} + \frac{\partial M}{\partial \xi} = -RM + Q, \quad (8.51)$$

where

$$Q = \begin{cases} 2e^{-\gamma\tau}R[t - \tau, \xi - \tau]M[t - \tau, \xi - \tau], & t > \tau, \quad \xi > \tau, \\ 2e^{-\gamma t}p_I[\xi - t, \tau - t]v(\xi - t), & t < \tau, \quad \xi > t, \\ 2e^{-\gamma\xi}V_0p_0[t - \xi, \tau - \xi], & t > \xi, \quad \xi < \tau. \end{cases} \quad (8.52)$$

This equation requires prescription of an initial condition for  $M$  at  $t = 0$ , and a boundary condition at  $\xi = 0$ , which will be derived in the following subsection. The effect of the initial condition is washed out of the system after a time

$$\xi_F = \int_0^{m_F} \frac{d\rho}{V(\rho)}. \quad (8.53)$$

After a time  $\tau$ , the effect of the initial condition for  $p_I$  becomes irrelevant, and only the first and third conditions in (8.52) are important.

### 8.5.1 Stem cell committal

Recall that we denote the primitive stem cell (age-dependent) densities to be  $p_0$  and  $n_0$  for proliferative and resting phases, respectively. By analogy to the committed cell lineage, conservation laws for these are of the form

$$\begin{aligned} \frac{\partial p_0}{\partial t} + \frac{\partial p_0}{\partial a} &= -(\gamma_0 + V_0)p_0, \\ \frac{\partial n_0}{\partial t} + \frac{\partial n_0}{\partial a} &= -(V_0 + R_0)n_0, \end{aligned} \quad (8.54)$$

where  $V_0$  is the rate of loss of stem cells to maturation, and  $\gamma_0$  is the apoptotic rate. We suppose they are constants. Note that  $V_0$  is unrelated to  $V$ , indeed the units of  $V_0$  and  $V$  are not even the same:  $V$  has units of  $\text{mat d}^{-1}$ , while  $V_0$  has units of  $\text{d}^{-1}$ . Note also that  $p_0$  and  $n_0$  have units of  $\text{cells age}^{-1}$  (unlike  $p$  and  $n$ ).

The primitive loss to maturation must balance the source for  $p$  and  $n$  at  $m = 0$ , thus

$$V_0p_0 = (Vp)|_{m=0}, \quad V_0n_0 = (Vn)|_{m=0}, \quad (8.55)$$

and the units are consistent.

Analogously to (8.30) and (8.31), we have

$$\begin{aligned} p_0(t, 0) &= R_0N_0, \\ n_0(t, \tau) &= 2p_0(t, \tau), \end{aligned} \quad (8.56)$$

where

$$N_0 = \int_{\tau}^{\infty} n_0 da. \quad (8.57)$$

Integration over  $a$  now yields

$$\frac{dN_0}{dt} = -V_0N_0 - R_0N_0 + 2p_0|_{a=\tau}, \quad (8.58)$$

and

$$(NV)|_{m=0} = N_0V_0. \quad (8.59)$$

In order to find  $p_0$  we must solve

$$\frac{\partial p_0}{\partial t} + \frac{\partial p_0}{\partial a} = -(\gamma_0 + V_0)p_0, \quad (8.60)$$

with parametric initial conditions on  $a = 0, s > 0$ :

$$p_0 = R_0(s)N_0(s), \quad a = 0, \quad t = s. \quad (8.61)$$

For  $t > a$ , the solution is

$$p_0 = R_0(t - a)N_0(t - a) \exp \left[ - \int_{t-a}^t (\gamma_0 + V_0) ds \right], \quad (8.62)$$

whereas for  $t < a$  the solution depends on the initial condition posed at  $t = 0, a > 0$ . Specifically, if  $p_0 = p_{00}(a)$  at  $t = 0$ , then

$$p_0 = p_{00}(a - t) \exp \left[ - \int_0^t (\gamma_0 + V_0) ds \right], \quad t < a. \quad (8.63)$$

Putting  $a = \tau$ , we find

$$\frac{dN_0}{dt} = -(R_0 + V_0)N_0 + 2R_0(t - \tau)N_0(t - \tau)e^{-(\gamma_0 + V_0)\tau}, \quad t > \tau, \quad (8.64)$$

which prescribes the control system for  $N_0$ . This is a precise analogue for (8.1)<sub>2</sub>, and indeed provides a formal derivation of the latter equation. It describes pluripotential stem cell control independently of the maturation process, providing we can assume the stem cell recruitment rate  $R_0$  is a function only of the resting stem cell population,  $N_0$ . For  $t < \tau$ , the equation for  $N_0$  involves the initial condition for  $p_0$ , and we can equivalently simply prescribe initial data for  $N_0$  there.

Finally, the two equations (8.64) and (8.48) are coupled through (8.59), which provides the requisite boundary condition for  $M$  at  $\xi = 0$ :

$$M = V_0N_0 \quad \text{at} \quad \xi = 0. \quad (8.65)$$

The equation for  $M$  itself takes the form, if we restrict attention to values of  $t > \tau$ ,

$$\frac{\partial M}{\partial t} + \frac{\partial M}{\partial \xi} = -RM + Q, \quad (8.66)$$

where

$$Q = \begin{cases} 2e^{-\gamma\tau}R[t - \tau, \xi - \tau]M[t - \tau, \xi - \tau], & \xi > \tau, \\ 2e^{-(\gamma_0 + V_0)\tau}e^{(\gamma_0 + V_0 - \gamma)\xi}V_0R_0(t - \tau)N_0(t - \tau), & \xi < \tau, \end{cases} \quad (8.67)$$

and we have used the appropriate expression (8.62) for  $p_0(t, a)$  in  $t > a$ .

## 8.5.2 Non-dimensionalisation

The equation (8.66) is simply non-dimensionalised. We write  $t$  and  $\xi$  in terms of  $\tau$ , and use  $N_0 V_0$  (or its mean) as a scale for  $M$ . In dimensionless terms, and for  $\xi > 1$ , (8.66) is now conveniently written in the form

$$\frac{\partial M}{\partial t} + \frac{\partial M}{\partial \xi} = -rM + (1 + \lambda)r_{1,1}M_{1,1}, \quad (8.68)$$

where  $M_{1,1} = M[t - 1, \xi - 1]$  (similarly for  $r$ ), and

$$\lambda = 2e^{-\gamma\tau} - 1 \quad (8.69)$$

should be positive (otherwise cell lines will die), and  $r = R\tau$ . Also,  $M = O(1)$  at  $\xi = 0$ .

## 8.5.3 Steady state

Let us suppose  $r$  in (8.68) is constant, and for simplicity ignore the distinct form of the equation when  $\xi < 1$ . The equation for  $M$  is linear, and has a steady solution of the form

$$M = e^{s\xi}, \quad (8.70)$$

where  $s$  is the unique positive root of

$$s = [(1 + \lambda)e^{-s\tau} - 1] r \quad (8.71)$$

(we assume  $\gamma\tau < \ln 2$ , so that  $\lambda > 0$ ). The cell density with respect to maturation time thus grows exponentially.

Direct consideration of (8.71) shows that  $s$  increases if  $R$  increases, and decreases if  $\tau$  or  $\gamma$  increase. If we use the same typical values of the parameters as before, i. e.,

$$R = 1.8 \text{ d}^{-1}, \quad \tau = 2.2 \text{ d}, \quad \gamma = 0.2 \text{ d}^{-1}, \quad (8.72)$$

then a good approximation to  $s$  is

$$s \approx \frac{r \ln(1 + \lambda)}{1 + r} \quad (8.73)$$

(see question 8.9 for a better approximation, as well how to derive this), and in fact this appears to be a uniformly good approximation. This suggests that  $s \sim O(1)$  (unless  $r \ll 1$ ), and thus that the amplification factor of the cell flux from committal to mature blood cell is  $\sim \exp(\xi_m)$ , where  $\xi_m$  is the dimensionless maturation time given by

$$\xi_m = \xi_F / \tau \quad (8.74)$$

( $\xi_F$  is the dimensional maturation time). Estimates of cell cycle time  $\tau$  of order 2 days, and of maturation time of order 20 days (in some cases) suggest an amplification of order  $10^4$ , and such a large amplification appears consistent with the apparent difficulty in isolating primitive stem cells (and thus their sparsity).

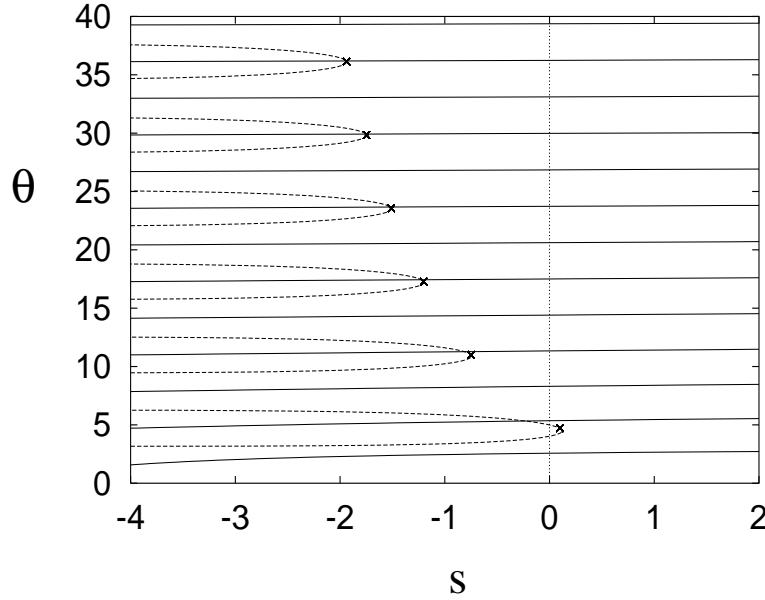

Figure 8.15: The zeros of (8.76) are the intersections of the solid curves  $s = -\alpha - \frac{\theta}{\tan \theta}$  and the dashed curves  $s = \ln \left\{ \frac{\Gamma \sin \theta}{\theta} \right\}$  in the complex  $\sigma = s + i\theta$  plane. The crosses are approximations for large  $\theta$ . Values used are  $\alpha = 4$  and  $\Gamma = -5.2$ .

### 8.5.4 Wave propagation

Suppose now that the primitive stem cell population  $N_0$  oscillates periodically, because of an instability in its control mechanism. If the period is  $2\pi/\omega$ , then (8.68) has solutions of the same period of the form

$$M = \sum_{p,q} c_{pq} e^{\sigma_q \xi + ip\omega(t-\xi)}, \quad (8.75)$$

provided  $\sigma_q$  satisfies a similar equation to (8.71), i. e.,

$$\sigma = -\alpha - \Gamma e^{-\sigma}, \quad (8.76)$$

where

$$\alpha = R\tau, \quad \Gamma = -R\tau(1 + \lambda). \quad (8.77)$$

Note that since a viable population requires  $\lambda > 0$ , we have  $\Gamma + \alpha < 0$ , and there is always a single positive root, which can be labelled with  $q = 0$  (see question 8.3). The others are complex (conjugates), and are labelled with increasing frequency as  $q = \pm 1, \pm 2$ , etc.

The complex roots are shown in figure 8.15, which also shows that the complex

roots  $\sigma = s \pm i\theta$  are well approximated by their high frequency approximation

$$\theta \approx \left(n + \frac{1}{2}\right) \pi, \quad n \in \mathbf{Z}_+, \quad s \approx -\ln \left( \frac{\left(n + \frac{1}{2}\right) \pi}{|\Gamma|} \right), \quad (8.78)$$

where  $n$  is even if  $\Gamma > 0$  and odd if  $\Gamma < 0$ ; it is only the lowest (and most unstable) frequency mode which is not adequately approximated.

The issue of whether *any* periodic initial data for (8.66) in the interval  $0 < \xi < \tau$  can be represented in the form (8.75) is tantamount to the issue of whether the modes  $\exp(\sigma\eta)$  form a complete basis for representation of functions of  $\eta \in (0, 1)$ . Such an enquiry is beyond the scope of the present notes.

(8.75) shows that periodic variations in stem cell density will propagate down the cell lineage as a travelling wave. For the normal case where  $\sigma_0 > 0$  and  $\text{Re } \sigma_q < 0$  for  $q \neq 0$ , the oscillatory components die away at large  $\xi$ , leaving only the ‘fundamental’,

$$M = \sum_p c_{p0} e^{\sigma_0 \xi + ip\omega(t-\xi)}, \quad (8.79)$$

a travelling wave whose amplitude grows as it propagates.

### 8.5.5 Spontaneous oscillations

Of course the solution in (8.75) also represents the steady state, if  $\omega = 0$ , or equivalently we select only the  $p = 0$  mode. In our discussion of the steady state, we selected the unique positive growing mode  $\sigma_0$  (denoted as  $s$  in (8.71)). The other complex modes could also be important if they have positive real part, causing oscillations as maturation progresses; and as figure 8.16 shows, such oscillatory modes do occur for larger values of  $|\Gamma|$ . For  $\alpha = 4$ , for example, the first complex pair of solutions of (8.76) has positive real part if  $|\Gamma| > 6.683$ . It seems feasible that such oscillations might swamp the exponential growth, but in fact this is not the case, since it is easy to show that  $\text{Re } \sigma_0 > \text{Re } \sigma_j$  for any complex  $\sigma_j$  with positive real part, so that the pure exponential growth term will dominate in general. (See also question 8.12.)

### 8.5.6 Peripherally controlled oscillations

The more interesting question concerning (8.68) is whether oscillatory instability can be induced by the dependence of the parameters on cell density. Various choices are possible, depending on which control concerns us. One obvious possibility is differentiation-induced control, where we might suggest that the recruitment rate  $r$  in (8.68) is a decreasing function of the total maturing cell density, i. e.,  $r = r(\bar{M})$ , where

$$\bar{M} = \int_0^{\xi_m} M d\xi. \quad (8.80)$$

This might be relevant in the development of acute myelogenous leukaemia, at the onset of blast crisis, when the body is flooded with immature blood cells.

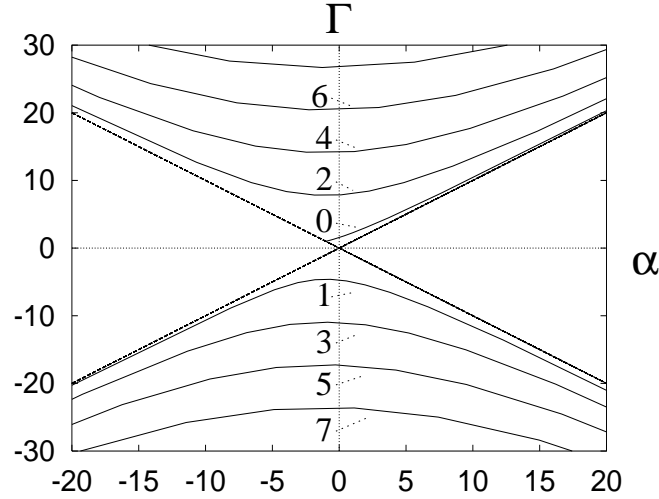

Figure 8.16: Expanded version of the map shown in figure 8.7. The curves are plotted parametrically as  $\alpha = -\Omega/\tan\Omega$ ,  $\Gamma = \Omega/\sin\Omega$ . Figure 8.7 showed the (principal) Hopf bifurcation curve corresponding to the range  $\Omega \in (0, \pi)$ ; further curves from the ranges  $(\pi, 2\pi)$ ,  $(2\pi, 3\pi)$ , etc., are added alternately above and below the  $\alpha$  axis in the order indicated (the curve labelled  $n$  corresponds to  $\Omega \in (n\pi, (n+1)\pi)$ ). Because  $\text{Re} \frac{\partial\sigma}{\partial\Gamma}\bigg|_{i\Omega} = \frac{\Gamma - \cos\Omega}{|\Gamma - e^{i\Omega}|^2}$  is positive for the curves above the  $\alpha$  axis and negative below, all of the pairs of eigenvalues  $\sigma$  cross the imaginary axis to the right as each bifurcation curve is crossed. Therefore between the curves labelled 1 and 3 there is one pair with  $\text{Re}\sigma > 0$ , between 3 and 5 there are two, and so on. The dashed lines are the asymptotes  $\Gamma = \pm\alpha$ .

The other possibility is peripheral control, where the mature blood cell density affects the differentiation rate of committed stem cells. For example, in erythropoiesis, we suppose the circulating erythrocyte density has a direct effect on the differentiation rate of pluripotential stem cells. To model this, let  $B$  be the number of circulating red blood cells<sup>3</sup>. The dimensionless flux of mature blood cells to the bloodstream is  $M(\xi_m, t)$ , and therefore a simple model for RBC number is

$$\frac{dB}{dt} = M(\xi_m, t) - aB, \quad (8.81)$$

where the second term represents the removal of RBC via apoptosis.<sup>4</sup> Since the stem cell committal rate is  $V_0$ , and this appears in the initial condition for  $M$  at  $\xi = 0$ , the natural way to include peripheral control in the model for  $M$  is to have the initial

<sup>3</sup>Rather than cell density, as it makes the units simpler.

<sup>4</sup>This first order decay term is equivalent to choosing an exponential distribution of death times, which is not very realistic, but will serve for illustration.



condition dependent on  $B$ , that is,

$$M = h(B) \quad \text{at} \quad \xi = 0. \quad (8.82)$$

Some advantage accrues if we suppose that  $\xi_m \gg 1$ , or  $\xi_F \gg \tau$ , meaning that the maturation time is significantly longer than the cell cycle time, or equivalently that there are a large number of generations in the cell lineage. Let us define

$$\varepsilon = \frac{1}{\xi_m}, \quad (8.83)$$

and the slow time and maturation scales

$$T = \varepsilon t, \quad X = \varepsilon \xi. \quad (8.84)$$

We also define

$$\lambda = \varepsilon \mu, \quad (8.85)$$

and suppose that  $\mu = O(1)$ . Essentially we are revisiting the relaxation oscillation analysis of section 8.3. The partial differential equation for  $M$  takes the form

$$\frac{\partial M}{\partial T} + \frac{\partial M}{\partial X} = \frac{-rM + r_{\varepsilon, \varepsilon} M_{\varepsilon, \varepsilon}}{\varepsilon} + \mu r_{\varepsilon, \varepsilon} M_{\varepsilon, \varepsilon}, \quad (8.86)$$

and expanding in a Taylor series as we did before, we have

$$\frac{\partial[(1+r)M]}{\partial T} + \frac{\partial[(1+r)M]}{\partial X} \approx \mu r M, \quad (8.87)$$

with the boundary condition

$$M = h(B) \quad \text{at} \quad X = 0. \quad (8.88)$$

If we suppose  $r$  is constant, then the solution of this is

$$M = h[B(T - X)] \exp\left[\frac{\mu r X}{1+r}\right], \quad (8.89)$$

and the emitted cell flux at  $X = 1$  ( $\xi = \xi_m$ ) is

$$M(1) = Ah[B(T - 1)], \quad (8.90)$$

where the amplification factor  $A$  is

$$A = \exp\left[\frac{\mu r}{1+r}\right]. \quad (8.91)$$

Therefore the RBC conservation law becomes the delay recruitment model

$$\frac{dB}{dT} = Ah(B_1) - \gamma B, \quad (8.92)$$

where  $\gamma = a\xi_m$ . We have seen this model relentlessly. Oscillations will occur as a consequence of instability of the (unique) steady state if  $A|h'|$  is large enough. Generally, as  $\gamma$  increases (RBC lifetime shortens), the equilibrium RBC number decreases and  $|h'|$  increases, thus promoting the kind of oscillations seen in haemolytic anaemia, for example.

## 8.6 Notes and references

### 8.6.1 Age and maturation

#### Exercises

8.1 Describe the way in which blood cells are produced, describe the different types of blood cell and explain their function. In what ways are cell numbers normally controlled?

For red blood cells, explain the rôle of hypoxia and erythropoietin in the control of differentiation.

A mathematical model of red blood cell numbers is given by the equation

$$\frac{dE}{dt} = F(E_\tau) - \gamma E,$$

where  $F(E)$  is assumed to be given by the Hill function

$$F = \frac{F_0 \theta^n}{E^n + \theta^n}.$$

In what way does this represent the effect of erythropoietin control?

Non-dimensionalise the model to obtain the form

$$\dot{\xi} = \frac{\rho}{1 + \xi^n} - \delta \xi,$$

and give the definitions of  $\rho$  and  $\delta$ . Use the values  $\gamma = 2 \times 10^{-2} \text{ day}^{-1}$ ,  $F_0 = 10^6$  cells  $\mu\text{l}^{-1}$ ,  $n = 8$ ,  $\theta = 3.5 \times 10^6$  cells  $\mu\text{l}^{-1}$ ,  $\tau = 6$  days, to evaluate  $\rho$  and  $\delta$ .

Show that there is a unique steady state  $\xi = \xi^*$ , and find approximate formulae for  $\xi^*$  when  $\delta \ll 1$  and  $\delta \gg 1$ . Draw a rough graph of  $\xi^*$  as a function of  $\delta$ .

Hence show that  $|f'(\xi^*)|$  varies non-monotonically with  $\delta$ , where  $f(\xi) = 1/(1 + \xi^n)$ , and that  $|f'(\xi^*)|$  is maximum when

$$\delta = \rho \left( \frac{n+1}{n-1} \right)^{1/n} \frac{n+1}{2n}.$$

Assuming that  $\delta$  is small, show that the steady state is unstable if, approximately,  $\rho|f'(\xi^*)| \gtrsim \pi/2$ , and deduce that, if  $n$  is large, this criterion is approximately

$$\delta n \gtrsim \frac{\pi}{2}.$$

8.2 What is meant by the  $G_0$  model of stem cell proliferation? Describe the way in which a simple model for the populations  $P$  of proliferative cells and  $N$  of resting cells can be written in the form

$$\dot{P} = -\gamma P + \beta(N)N - e^{-\gamma\tau}\beta(N_\tau)N_\tau,$$

$$\dot{N} = -\beta(N)N - \delta N + 2e^{-\gamma\tau}\beta(N_\tau)N_\tau.$$

Suppose that  $\beta(N)$  is given by the Hill function

$$\beta(N) = \frac{\beta_0\theta^n}{\theta^n + N^n}.$$

By suitably non-dimensionalising the model, derive the dimensionless form

$$\dot{N} = g(N_1) - g(N) + \varepsilon[\mu g(N_1) - N],$$

where

$$g(N) = \frac{bN}{1 + N^n},$$

and give the definitions of the parameters  $\mu$ ,  $b$  and  $\varepsilon$ .

Use the values  $\theta = 2 \times 10^3$  cells  $\mu\text{l}^{-1}$ ,  $\beta_0 = 1.8 \text{ d}^{-1}$ ,  $\gamma = 0.2 \text{ d}^{-1}$ ,  $\delta = 0.05 \text{ d}^{-1}$ ,  $\tau = 2.2 \text{ d}$ , to find typical values of  $b$ ,  $\mu$  and  $\varepsilon$ .

Show that there is a unique positive steady state if  $\mu\beta > 1$ , and show that it is unstable if  $\text{Re } \sigma > 0$ , where

$$\sigma = -\alpha - \gamma e^{-\sigma},$$

and

$$\alpha = g' + \varepsilon, \quad \gamma = -(1 + \varepsilon\mu)g'.$$

8.3 Suppose that  $\sigma$  satisfies

$$\sigma = -\alpha - \gamma e^{-\sigma},$$

where  $\alpha$  and  $\gamma$  are (not necessarily positive) constants.

Show that if  $\alpha > 0$ ,  $\text{Re } \sigma < 0$  if  $|\gamma| < \alpha$ , and that  $\sigma = 0$  is a root if  $\gamma = -\alpha$ .

Show that  $\sigma = \pm i\Omega \neq 0$  if  $\gamma = \Gamma_0(\alpha)$ , where

$$\tan \Omega = -\frac{\Omega}{\alpha}, \quad \Gamma_0 = \frac{\Omega}{\sin \Omega},$$

for  $\Omega \in [0, \pi]$ . Show that  $\Gamma_0(\alpha)$  is a positive monotone increasing function of  $\alpha$  which terminates at  $\alpha = -1$ , where  $\Gamma_0 = 1$ .

By consideration of the graph of  $\sigma - \gamma(1 - e^{-\sigma})$ , show that when  $\gamma + \alpha = 0$ ,  $\sigma = 0$  is the only real root if  $\gamma < 0$ , there is a second which is negative if  $0 < \gamma < 1$ , and a second which is positive when  $\gamma > 1$ .

Show that when  $\gamma > 0$ , the two real roots collide when  $\gamma = \gamma_c(\alpha) = \exp[-(\alpha + 1)]$ .

Use the above facts to show that, if  $\sigma_+$  and  $\sigma_-$  denote the two roots  $\pm i\Omega$  when  $\gamma = \Gamma_0$ , then

$$\sigma_{\pm} \text{ are complex for } \alpha \in (\gamma_c^{-1}(\gamma), \Gamma_0^{-1}(\gamma)), \text{ and } \text{Re } \sigma_{\pm} > 0;$$

$\sigma_{\pm}$  are complex for  $\gamma \in (\gamma_c(\alpha), \Gamma_0(\alpha))$ , and  $\text{Re } \sigma_{\pm} < 0$ ;

$\sigma_{\pm}$  are real for  $\gamma < \gamma_c(\alpha)$ , and:

$$\sigma_{\pm} > 0 \text{ for } \gamma \in (-\alpha, \gamma_c(\alpha)) \text{ when } \alpha < -1;$$

$$\sigma_{\pm} < 0 \text{ for } \gamma \in (-\alpha, \gamma_c(\alpha)) \text{ when } \alpha > -1;$$

$$\sigma_+ > 0 > \sigma_- \text{ for } 0 < \gamma < -\alpha, \alpha < 0;$$

there is only one real root  $\sigma_+$  for  $\gamma < 0$ , and:

$$\sigma_+ > 0 \text{ for } \gamma < -\alpha, \sigma_+ < 0 \text{ for } \gamma > -\alpha.$$

Hence sketch the stability regions in  $(\gamma, \alpha)$  parameter space.

Use the definitions in question 8.2 to show that  $\gamma + \alpha \geq 0$ , and deduce that the positive fixed point is oscillatorily unstable for large enough  $\mu$  if  $0 > g' > -1 - \varepsilon$ , and that it is unstable for  $g' < -1 - \varepsilon$ .

8.4 Red blood cell precursors are produced from pluripotential stem cells in the bone marrow at a rate  $F$ . They mature for a period of  $\tau$  days before being released into the blood, where they circulate for a further  $A$  days. If the apoptotic rates in bone marrow and blood are  $\delta$  and  $\gamma$ , respectively, show that the developing cell density  $p$  and circulating RBC density  $e$  satisfy the equations

$$\begin{aligned} \frac{\partial p}{\partial t} + \frac{\partial p}{\partial m} &= -\delta p, \\ \frac{\partial e}{\partial t} + \frac{\partial e}{\partial a} &= -\gamma e, \end{aligned}$$

for  $0 < m < \tau$  and  $0 < a < A$ , where

$$p(t, 0) = F[E(t)], \quad e(t, 0) = p(t, \tau),$$

and we assume  $F$  depends on the total circulating blood cell population,

$$E = \int_0^A e \, da.$$

Solve the equations using the method of characteristics, and hence show that for  $t > \tau + A$ ,  $E$  satisfies

$$\dot{E} = F[E_{\tau}]e^{-\delta\tau} - F[E_{A+\tau}]e^{-\delta\tau-\gamma A} - \gamma E, \quad t > \tau + A.$$

Compare this model to that which assumes no age limit to the circulating RBC. Under what circumstances does the model reduce to the no age limit model?

Suppose that  $F = F_0 f$ , where  $f$  is  $O(1)$  and is a positive monotone decreasing function. Show how to non-dimensionalise the model to the form

$$\dot{E} = \mu[f(E_1) - f(E_{\Lambda+1})e^{-\mu\Lambda} - E],$$

where  $\mu = \gamma\tau$  and  $\Lambda = A/\tau$ . Supposing that  $A = 120$  days and  $\tau = 6$  days, explain why you might expect  $\mu$  to be small.

Write down an equation for the exponent  $\sigma$  in solutions  $\propto \exp(\sigma t)$  describing small perturbations about the steady state, and show that if  $\sigma \sim O(1)$ , then the steady state is stable if  $|f'| < 1$ .

8.5 The function  $g(N)$  is defined by

$$g(N) = \frac{bN}{1 + N^n},$$

where  $b$  and  $n$  are positive. Suppose that  $\mu$  is positive. Show that there is a unique positive solution  $N^*$  of the equation  $N = \mu g(N)$  providing  $\mu b > 1$ . By graphical means, or otherwise, show that  $1 - \mu g'(N^*) > 0$ .

Now suppose that the parameters  $\Gamma$  and  $\alpha$  are defined by

$$\Gamma = -(1 + \varepsilon\mu)g', \quad \alpha = g' + \varepsilon,$$

where  $g' = g'(N^*)$  and  $\varepsilon$  is small and positive. Show that  $\Gamma + \alpha > 0$  and that  $\alpha < -1$  if  $g' + 1 < -\varepsilon$ .

Let  $\Gamma_0(\alpha)$  be defined by

$$\tan \Omega = -\frac{\Omega}{\alpha}, \quad \Gamma_0 = \frac{\Omega}{\sin \Omega},$$

for  $\Omega \in (0, \pi)$ . Show that as  $\Omega \rightarrow 0$ ,  $\Gamma_0 \approx 1 + \frac{1}{6}\Omega^2$ ,  $\alpha + 1 \approx \frac{1}{3}\Omega^2$ , and deduce that

$$\Gamma_0 \approx 1 + \frac{1}{2}(\alpha + 1) \dots$$

as  $\alpha \rightarrow -1$ . Hence show that for small  $\varepsilon$ ,  $\Gamma > \Gamma_0(\alpha)$  if, approximately,  $\alpha + 1 \lesssim \frac{2}{3}\varepsilon(\mu + 1)$ .

Deduce that for small  $\varepsilon$ , the instability criterion  $\alpha < -1$  or  $\Gamma > \Gamma_0(\alpha)$  is satisfied if

$$g' \lesssim -1 + \frac{2}{3}\varepsilon(\mu - \frac{1}{2}).$$

8.6 The Hopf bifurcation curve in figure 8.7 is defined parametrically by

$$\Gamma_0(\alpha) = \frac{\Omega}{\sin \Omega}, \quad \alpha = -\frac{\Omega}{\tan \Omega},$$

for  $\Omega \in (0, \pi)$ . By expanding for small  $\Omega$ , show that

$$\Gamma_0 = 1 + \frac{1}{6}\Omega^2 + \frac{7}{360}\Omega^4 + \frac{31}{15120}\Omega^6 + O(\Omega^8),$$

and that

$$\alpha + 1 = \frac{1}{3}\Omega^2 + \frac{1}{45}\Omega^4 + \frac{2}{945}\Omega^6 + O(\Omega^8).$$

Deduce that

$$\Gamma_0 = 1 + \frac{1}{2}(\alpha + 1) + \frac{3}{40}(\alpha + 1)^2 - \frac{9}{2800}(\alpha + 1)^3 + O[(\alpha + 1)^4],$$

i. e.,

$$\Gamma_0 \approx 1 + 0.5(\alpha + 1) + 0.075(\alpha + 1)^2 - 0.0032(\alpha + 1)^3 + O[(\alpha + 1)^4].$$

Plot  $\Gamma_0$  versus  $\alpha$  using suitable graphical software, and show that an accurate quadratic approximation for  $\alpha \in (-1, 2)$  is

$$\Gamma_0 \approx 1 + 0.5(\alpha + 1) + 0.058(\alpha + 1)^2,$$

and that an accurate cubic approximation for  $\alpha \in (-1, 5)$  is

$$\Gamma_0 \approx 1 + 0.5(\alpha + 1) + 0.075(\alpha + 1)^2 - 0.005(\alpha + 1)^3.$$

Can you find a value of  $c$  for which

$$\Gamma_0 \approx 1 + 0.5(\alpha + 1) + 0.075(\alpha + 1)^2 - 0.0032(\alpha + 1)^3 + c(\alpha + 1)^4$$

provides an accurate approximation for larger values of  $\alpha$ ?

Show (plot it and compare with the quadratic approximation) that a better two coefficient approximation is given by

$$\Gamma_0 = \frac{1 + b(\alpha + 1) + c(\alpha + 1)^2}{1 + c(\alpha + 1)},$$

if  $b = 0.65$  and  $c = 0.15$ . Why would these values of  $b$  and  $c$  be chosen? Show (graphically) that an even better approximation is obtained if  $b = 0.69$  and  $c = 0.3$ . (The maximum error for  $\alpha < 100$  is less than 0.05.) How could you extend this type of approximation to larger values of  $\alpha$ ?

8.7 Suppose that  $v$  and  $N$  satisfy the pair of ordinary differential equations

$$\begin{aligned}\varepsilon N' &= v - g(N), \\ N' + v' &= \mu g(N) - N - \varepsilon \mu v',\end{aligned}$$

where  $N' = dN/dT$ ,  $\varepsilon$  is small and

$$g(N) = \frac{bN}{1 + N^n};$$

the parameters  $\varepsilon$ ,  $b$ ,  $\mu$  and  $n$  are all positive, and  $n > 1$ .

Let

$$b_c = \frac{4n}{(n-1)^2},$$

and suppose that  $b > b_c$ . Let  $\mu_{\pm}$  be the roots ( $\mu_- < \mu_+$ ) of

$$b\mu^2 - (n-1)b\mu + n = 0,$$

and suppose that  $\mu_- < \mu < \mu_+$ . Show that  $\mu_-b > 1$ .

Let

$$N_{\pm} = \mu_{\pm}b - 1,$$

and let  $N_U$  and  $N_L$  be the values of  $N$  where the lines of slope  $-1$  through  $N_-$  and  $N_+$ , respectively, intersect  $g(N)$ .

Show that a relaxation oscillation occurs, and describe diagrammatically (in terms of  $N_-$ ,  $N_U$ ,  $N_+$  and  $N_L$ ) how  $N$  and  $v$  vary during the oscillation in the  $(N, v)$  phase plane.

Show that the period is approximately  $P_0$ , where

$$P_0 = \int_{N_+}^{N_U} \left( \frac{1+g'}{N-\mu g} \right) dN + \int_{N_L}^{N_-} \left( \frac{1+g'}{\mu g - N} \right) dN.$$

8.8 Derive the equation of conservation of proliferating cells in an age and maturation structured model of cell development,

$$\frac{\partial p}{\partial t} + \frac{\partial p}{\partial a} + \frac{\partial(Vp)}{\partial m} = -\gamma p,$$

from first principles, by consideration of a suitable integral conservation law.

If  $r^*(t, m)$  is the rate of recruitment of resting phase cells to the proliferative phase, derive the recruitment condition at  $a = 0$ ,

$$p(t, m, 0) = r^*(t, m).$$

Now suppose that  $V = V(m) > 0$  and that  $\gamma$  is constant, and that additional initial/boundary conditions are

$$p = p_I^*(m, a) \quad \text{at} \quad t = 0,$$

$$pV = q(t, a) \quad \text{at} \quad m = 0.$$

Show that, if  $Q = 2p(t, m, \tau)V(m)$ , then

$$Q = \begin{cases} 2e^{-\gamma\tau}r[t-\tau, \xi-\tau]v(\xi-\tau), & t > \tau, \quad \xi > \tau, \\ 2e^{-\gamma t}p_I[\xi-t, \tau-t]v(\xi-t), & t < \tau, \quad \xi > t, \\ 2e^{-\gamma\xi}q[t-\xi, \tau-\xi], & t > \xi, \quad \xi < \tau. \end{cases}$$

where

$$\xi = \int_0^m \frac{d\rho}{V(\rho)}$$

and

$$v(\xi) = V(m), \quad p_I(\xi, a) = p_I^*(m, a), \quad r(t, \xi) = r^*(t, m).$$

8.9 The positive constant  $\alpha$  is determined by the solution of the transcendental equation

$$\alpha = R[(1 + \lambda) \exp(-\alpha\tau) - 1],$$

where  $\lambda$ ,  $R$  and  $\tau$  are positive constants. Suppose that typical values of these are  $\lambda = 0.288$ ,  $R = 1.8$ , and  $\tau = 2.2$ . Show that  $\Lambda = \lambda R\tau \approx 1.14$ .

Hence show that an approximate solution for  $\alpha$  based on the estimates  $\Lambda \sim 1$ ,  $\lambda \ll 1$ , can be written in the form

$$\alpha \approx \frac{R}{1 + R\tau} \left[ \ln(1 + \lambda) + \frac{1}{2} \left( \frac{\ln(1 + \lambda)}{1 + R\tau} \right)^2 \dots \right].$$

Figure 8.17 shows that this approximation is essentially exact for all  $\lambda \in (0, 1)$  when  $\Lambda = 1.14$ . Plot the approximate exact solutions numerically for other values of  $\Lambda$ , and show that the approximation remains excellent for all  $\Lambda \gtrsim 0.2$ .

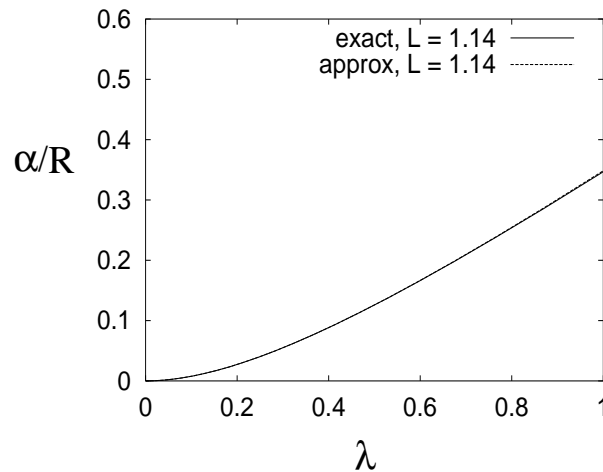

Figure 8.17: Approximate and exact solutions for ( $L =$ )  $\Lambda = 1.14$ . The approximation is essentially exact for all  $\lambda$ , and this remains true for all  $\Lambda > 0.2$ .

*It may be useful to define  $a = \alpha/\lambda R$ , and then show that*

$$a = \frac{1}{\Lambda} [\ln(1 + \lambda) - \ln(1 + \lambda a)],$$

*whence  $a = O(\lambda)$ , so that*

$$a \approx \frac{1}{\Lambda} [\ln(1 + \lambda) - \lambda a + \frac{1}{2} \lambda^2 a^2].$$



8.10 The complex quantity  $\sigma = s + i\theta$  satisfies the transcendental equation

$$\sigma = -\alpha - \Gamma e^{-\sigma}.$$

Show that the roots are given by the intersection of the curves

$$s = -\alpha - \frac{\theta}{\tan \theta}$$

and

$$s = \ln \left\{ \frac{\Gamma \sin \theta}{\theta} \right\}.$$

Show that as  $\sigma \rightarrow \infty$ ,  $s \rightarrow -\infty$ , and deduce that for roots with  $\theta > 0$ ,

$$\theta \approx \left(n + \frac{1}{2}\right) \pi, \quad s \approx -\ln \left( \frac{\left(n + \frac{1}{2}\right) \pi}{|\Gamma|} \right),$$

where  $n$  is an even integer for  $\Gamma > 0$  and an odd integer for  $\Gamma < 0$ .

Plot the exact and approximate roots for  $\alpha = 1$  and  $\Gamma = 2$ , and show that the two sets are the same except for the lowest frequency root.

8.11 Show that if, in (8.66) and (8.67),  $R = (1 + \lambda)R_0$ ,  $\lambda = 2e^{-\gamma\tau} - 1$ ,  $\gamma_0 + V_0 = \gamma$ , and all these quantities and also  $N_0$  are constant, then the equation (8.66) for  $M$  can be written as

$$\frac{\partial M}{\partial t} + \frac{\partial M}{\partial \xi} = -RM + (1 + \lambda)RM_{1,1},$$

with initial data being

$$M = M_0 = N_0V_0 \quad \text{for} \quad \xi \in (0, \tau) \quad \text{and} \quad t > \xi.$$

By careful consideration of how the characteristic equations are solved, show that for  $t > \xi$ ,  $M = M(\xi) \equiv M_0u[(\xi - \tau)/\tau]$ , where  $u(t)$  satisfies

$$\frac{du}{dt} = -\alpha u - \Gamma u_1,$$

and  $\alpha = R\tau$ ,  $\Gamma = -(1 + \lambda)R\tau$ , and  $u = 1$  for  $t \in [-\tau, 0)$ .

By taking the Laplace transform of the equation (exercising due care with the delayed term), show that the Laplace transform  $U(p)$  of  $u$  is given by

$$U(p) = \frac{h(p)}{f(p)},$$

where

$$f(p) = p + \alpha + \Gamma e^{-p}$$

and

$$h(p) = 1 - \Gamma \left( \frac{1 - e^{-p}}{p} \right).$$

Deduce that  $U$  can also be written as

$$U(p) = \frac{\Lambda e^p}{p[(p + \alpha)e^p + \Gamma]} + \frac{1}{p},$$

where

$$\Lambda = \lambda R \tau.$$

Hence show that if the inversion contour for  $U$  is completed as a square with upper and lower sides at  $\text{Im } p = \pm(n + \frac{1}{2})\pi$ , with  $n$  even for  $\Gamma < 0$ , as here, then by taking the limit as  $n \rightarrow \infty$ ,  $u$  can be found as

$$u = \sum_{j=-\infty}^{\infty} c_j \exp(p_j t),$$

where  $p_j$  are the zeros of  $f(p)$ . Write down the definition of the constants  $c_j$  in terms of  $p_j$ , and show that they can be expressed as

$$c_j = \frac{1}{p_j(1 + \alpha + p_j)},$$

so that  $c_j = O(1/j^2)$  for  $j \gg 1$ .

8.12 Suppose that  $u(t)$  satisfies the functional differential equation

$$\dot{u} = -\alpha u - \Gamma u_1,$$

where  $u_1 = u(t - 1)$ , and  $\alpha > 0$  and  $\Gamma < 0$ . If the initial function is  $u = 1$  for  $t \in [-1, 0)$ , show that  $u > 0$  for all  $t > 0$ .

Show that solutions  $u = \exp(\sigma t)$  satisfy the transcendental equation

$$\sigma = -\alpha - \Gamma e^{-\sigma}.$$

Show that there exists precisely one real root  $\sigma_0$  of this equation, and that it is positive if also  $\Gamma < -\alpha$ .

Let  $s + i\omega$  be any complex root of the transcendental equation. Show that if  $\sigma_0 > 0$  and also  $s > 0$ , then necessarily  $\sigma_0 > s$ .

Show that if  $\sigma = i\Omega$  for some values of  $\alpha$  and  $\Gamma$ , then

$$\Gamma = \frac{\Omega}{\sin \Omega}, \quad \alpha = -\frac{\Omega}{\tan \Omega}.$$

This defines a family of curves  $C_n$  labelled by the value of the integer  $n \geq 0$ , where  $\Omega \in (n\pi, (n+1)\pi)$ . Show that on each curve  $C_n$ ,

$$\operatorname{Re} \frac{\partial \sigma}{\partial \Gamma} \Big|_{i\Omega} = \frac{\Gamma - e^{-i\Omega}}{|\Gamma - e^{i\Omega}|^2},$$

and deduce that the imaginary values of  $\sigma$  on each  $C_n$  cross from left to right as  $|\Gamma|$  increases. (*Hint: note that  $|\Gamma| = |\Omega/\sin \Omega| > 1$  for all  $\Omega$ .*) Hence evaluate the number of complex zeros with  $\operatorname{Re} \sigma > 0$  between  $C_n$  and  $C_{n+2}$ , for any value of  $n$ .

Show that a crude approximation to  $C_n$  when  $n$  is large is

$$\Gamma \approx (-1)^n [\alpha^2 + n^2\pi^2]^{1/2},$$

and thus that a better one is

$$\Gamma \approx (-1)^n \left[ \alpha^2 + \left\{ n\pi + \cos^{-1} \left( \frac{-\alpha}{\sqrt{\alpha^2 + n^2\pi^2}} \right) \right\}^2 \right]^{1/2}.$$

Show graphically that the better approximation is excellent for  $n \geq 1$ .

# Glossary

*Acetylcholine*

*Adrenaline (epinephrine)*

*Afferent nerves*

*Alveoli*

*Aorta*

*Apnea*

Absence of breathing.

*Apoptosis*

Pre-programmed cell death.

*Apneustic centre*

*Arteries*

These are the blood vessels which carry freshly oxygenated blood from the (left ventricle of the) heart to the tissues, where the oxygen load is consumed, and metabolically produced carbon dioxide is taken up.

*Autonomic control*

*Baroreceptors*

*Baroreflex*

*Basophil*

*Blast cells*

*Bradycardia*

A slow heart rate.

*Bronchi*

*Capillary bed*

As the arteries transport blood away from the heart, they divide into finer and finer passageways, first arterioles, and finally capillaries, extremely thin tubes which perfuse tissue and which can efficiently exchange blood gases with the tissue cells.

*Carbonic anhydrase*

An enzyme contained in red blood cells which facilitates the reaction of water and carbon dioxide to form bicarbonate ions, in which form most of the CO<sub>2</sub> in the blood is transported.

*Carotid arteries*

*Carotid sinus*

*Catecholamines*

*Cerebro-spinal fluid (CSF)*

*Chemoreceptors*

*Cheyne-Stokes respiration*

This is an oscillatory kind of breathing in which a waxing and waning pattern of breathing alternates with periods of complete *apnea*, with a typical period of a minute or so. Common causes of Cheyne-Stokes breathing are heart failure, stroke, and ascent to high altitude, when the period is less.

*Chronotropic effect*

*Compliance*

*Dead space*

*Diaphragm*

*Diastole*

*Dicrotic notch*

*Dorsal respiratory neurons*

*Efferent nerves*

*Elastance*

*Eosinophil*

*Erythrocytes*

*Erythropoietin*

A hormone which controls red blood cell production. Low blood oxygen levels stimulate production of erythropoietin in the kidneys, and this in turn stimulates erythrocyte production in the marrow, by encouraging the production of proerythroblasts, and by quickening their rate of maturation to form erythrocytes.

*Glossopharyngeal nerves*

*Granulocytes*

A collective name for the three types of white blood cell having a granular appearance: neutrophils, basophils, and eosinophils.

*Granulopoietin*

*Haematocrit*

The percentage of blood consisting of cells.

*Haematopoietic stem cells*

These are the most primitive cells resident in the bone marrow, which collectively give rise to the various kinds of blood cells: *erythrocytes*, *platelets* and white blood cells. The process of maturation which they undergo is called differentiation. Isolation of stem cells is difficult, insofar as no real most primitive cell has ever been really identified. It is likely that stem cells are very scarce, and that they can survive in the resting phase for a long time.

*Haemoglobin*

*Hypercapnea*

*Hyperpnea*

*Inotropic effect*

*Intercostal muscles*

*Leukocytes*

General term for white blood cells.

*Lymph nodes*

*Lymphocytes*

*Mayer waves*

*Megakaryocytes*

*Minute ventilation*

*Monocyte*

*Myelocytes*

*Myocytes*

*Myocardium*

*Neutrophil*

*Noradrenaline (norepinephrine)*

*Parasympathetic nervous system*

*Phagocytosis*

The process of cell ingestion by means of which granulocytes and monocytes destroy antigens.

*Plasma cells*

*Platelets*

Platelets are cell fragments which are formed by the disintegration of *megakaryocytes*. They circulate in the blood with a life span of about ten days, and are instrumental in clotting during wound healing.

*Pneumotaxic centre*

*Residual volume*

*Respiratory sinus arrhythmia*

*Reticulocytes*

*Stroke volume*

*Sympathetic nervous system*

*Systole*

*Thoracic cavity*

*Thrombocytes*

Another name for *platelets*.

*Thrombocytopenia*

A disease signalled by low circulating numbers of thrombocytes, or platelets.

*Thrombocytopenic purpura*

Another name for thrombocytopenia, arising from the purplish blotches on the skin of those afflicted.

*Thrombopoietin*

*Tidal volume*

*Trachea*

*Vagus nerves*

*Vasoconstriction*

*Vasodilation*

*Veins*

*Ventral respiratory neurons*

*Windkessel*



## References

- Batzel, J. J. and H. T. Tran 2000a Modeling variable delay and instability in the control system for human respiration: application to infant non-rem sleep. *J. Appl. Math. Comp.* **110**, 1–51.
- Berne, R. M. and M. N. Levy 1996 Principles of physiology, 2nd ed. Mosby, St. Louis.
- Brown, H. and R. Kozlowski 1997 Physiology and pharmacology of the heart. Blackwell Science, Oxford.
- De Boer, R. W., J. M. Karemaker and J. Strackee 1987 Hemodynamic fluctuations and baroreflex sensitivity in humans: a beat-to-beat model. *Amer. J. Physiol.* **253**, 680–689.
- Fowler, A. C. 2013 Note on a paper by Omta *et al.* on sawtooth oscillations. *SeMA Journal* **62**, 1–13.
- Fowler, A. C. 2014 Starvation kinetics of oscillating microbial populations. *Math. Proc. R. Ir. Acad.* **114** (2), 173–189.
- Glass, L. and M. C. Mackey 1988 From clocks to chaos. Princeton University Press, Princeton, New Jersey.
- Grindrod, P. 1991 Patterns and waves. O. U. P., Oxford.
- Grodins, F. S., J. Buell and A. J. Bart 1967 Mathematical analysis and digital simulation of the respiratory control system. *J. Appl. Physiol.* **22**, 260–276.
- Guyton, A. C. and J. E. Hall 2000 Textbook of Medical Physiology, 10th ed. W. B. Saunders, Philadelphia.
- Houghton, A. R. and D. Gray 1997 Making sense of the ECG, a hands-on guide. Arnold, London.
- Huppert, A., B. Blasius, R. Olinky and L. Stone 2005 A model for seasonal phytoplankton blooms. *J. Theor. Biol.* **236**, 276–290.
- Julian, D. G., J. C. Cowan and J. M. McLenachan 1998 Cardiology. Saunders, Edinburgh.
- Katz, B. 1966 Nerve, muscle and synapse. McGraw-Hill, New York.
- Keener, J. and J. Sneyd 1998 Mathematical physiology. Springer-Verlag, Berlin.
- Khoo, M. C. K., R. E. Kronauer, K. P. Strohl, and A. S. Slutsky 1982 Factors inducing periodic breathing in humans: a general model. *J. Appl. Physiol.* **53**, 644–659.

- Levick, J. R. 2000 An introduction to cardiovascular physiology, 3rd ed. Butterworth-Heinemann, Oxford.
- Lewis, T. 1925 Mechanism and graphical registration of the heart beat. Shaw and Sons, London.
- Mackey, M.C. and L. Glass 1977 Oscillations and chaos in physiological control systems. *Science* **197**, 287–289.
- Murray, J.D. 1993 Mathematical biology, 2nd ed. Springer-Verlag, Berlin.
- Omta, A.W., G.A.K. van Voorn, R.E.M. Rickaby and M.J. Follows 2013 On the potential role of marine calcifiers in glacial-interglacial dynamics. *Global Biogeochem. Cycles* **27**, 692–704.
- Ottesen, J. T. 1997 Modelling of the baroreflex-feedback mechanism with time-delay. *J. Math. Biol.* **36**, 41–63.
- Segel, L. A. 1984 Modeling dynamic phenomena in molecular and cellular biology. C. U. P., Cambridge.
- Ursino, M. 1998 Interaction between carotid baroregulation and the pulsating heart: a mathematical model. *Amer. J. Physiol.* **275**, H1733–H1747.
- Whitham, G. B. 1974 Linear and nonlinear waves. John Wiley, New York.