

A2.2: Complex Analysis

Dmitry Belyaev¹

May 16, 2026

¹These notes are closely based on previous versions of the notes by Kevin McGerty, Ben Green, Panos Papazoglou and Richard Earl. Many thanks to them all. The syllabus of the course has been changed since 2024. Please contact Dmitry Belyaev belyaev@maths.ox.ac.uk if you have any comments or corrections.

Contents

Foreword	iii
0.1 Synopsis	iii
0.2 Further reading	iv
Introduction	v
0.3 Basic notations	v
1 Complex differentiability	1
1.1 Complex differentiability	2
1.2 Cauchy-Riemann equations	4
1.2.1 Wirtinger derivatives	8
1.3 Harmonic functions	10
1.4 Power series	11
1.4.1 Power series about other points	14
1.4.2 The exponential and trigonometric functions	14
1.4.3 Properties of exponential and trigonometric functions	16
1.4.4 Logarithms and powers	17
1.5 Branch cuts and multifunctions	20
2 Paths and Integration	27
2.1 Paths	27
2.2 Integration along a path	30
2.3 Cauchy's theorem	40
2.4 Deformation theorem and homotopy	45
2.5 Winding numbers	49
3 Cauchy's Formula and its applications	55
3.1 Cauchy's Integral Formula	55
3.2 Homotopy version of Cauchy's theorem	58
3.2.1 Cycles	58

3.2.2	The homology form of Cauchy's theorem	61
3.3	Applications of the Integral Formula	63
3.4	The identity theorem	66
3.5	Isolated singularities	68
3.6	The argument principle	77
3.7	Applications of the Residue theorem	80
3.7.1	On the computation of residues	81
3.7.2	Residue Calculus	84
3.7.3	Jordan's Lemma and applications	86
3.7.4	Summation of infinite series	90
3.7.5	Keyhole contours	92
Appendices		95
A Homotopy version of Cauchy's theorem		99
B Remark on the Inverse Function Theorem		105

Foreword

The aim of this part of the course is to study functions $f : \mathbb{C} \rightarrow \mathbb{C}$, asking what it means for them to be differentiable, how to integrate them, and looking at the applications of all this. We will see that complex differentiation is only superficially similar to the real differentiation and complex differentiable functions have a lot of unique properties. One of the main goals of this course is to explore a beautiful and very unusual theory of such functions.



In these lecture notes there will be several parts with the danger sign in the margin. This sign gives you a warning that this is a more tricky part and it is easy to make a mistake if you don't pay enough attention.



I will use the star in the margin to mark several remarks that I think are very important and give valuable intuition about what is going on.



Finally, there will be several smaller bits that are not part of the syllabus and not examinable. They will be explicitly marked as non-examinable material and there will be a marginal sign.

0.1 Synopsis

Complex differentiation. Holomorphic functions. Cauchy-Riemann equations (different versions). Real and imaginary parts of a holomorphic function are harmonic. [2 lectures]

Recap on power series and differentiation of power series. Exponential function and logarithm function. Fractional powers — examples of multi-functions. The use of cuts as a method of defining a branch of a multifunction. [2 lectures]

Path integration. Winding numbers. Cauchy's Theorem (partial proof only). Homology form of Cauchy's Theorem (sketch of proof only — students referred to various texts for proof.) Fundamental Theorem of Calculus in the path integral/holomorphic situation. [4 lectures]

Cauchy's Integral formulae. Taylor expansion. Liouville's Theorem. Morera's Theorem. Identity Theorem. [2 lectures]

Laurent's expansion. Classification of isolated singularities. Calculation of principal parts, particularly residues. The argument principle and applications. [3 lectures]

Residue Theorem. Evaluation of integrals by the method of residues (straightforward examples only but to include the use of Jordan's Lemma and simple poles on contour of integration). [3 lectures]

0.2 Further reading

These lecture notes provide all the essential information for the course and they follow lectures quite closely. On the other hand, there are many excellent textbooks that discuss the foundations of complex analysis in more detail and (very importantly!) from slightly different perspectives. If you are stuck with one of the arguments in these notes I advise you to consult other sources that could explain it in a different way. There is a huge list of Complex Analysis textbooks. I do not aim to provide a comprehensive list, below are just a few textbooks that I like.

Lars V. Ahlfors. Complex analysis. Third Edition. New York: McGraw-Hill, 1979.

Churchill, Ruel V.; Brown, James Ward Complex variables and applications. 4th ed. McGraw-Hill Book Company. X, 339 p. (1984).

Conway, John B. Functions of one complex variable. (English) Zbl 0277.30001 Graduate Texts in Mathematics. 11. New York-Heidelberg-Berlin: Springer-Verlag. xi, 313 p. (1973).

Gamelin, Theodore W. Complex analysis. (English) Zbl 0978.30001 Undergraduate Texts in Mathematics. New York, NY: Springer. xvi, 478 p. (2001).

Needham, Tristan Visual complex analysis. 25th-anniversary edition. With a new foreword by Roger Penrose. Oxford: Oxford University Press 675 p. (2023).

Introduction

0.3 Basic notations

This course runs in parallel with the Metric Spaces course. We will use some notions and a few results from metric spaces.

We can identify \mathbb{C} with the plane \mathbb{R}^2 by taking real and imaginary parts. Thus we have the correspondence

$$z \in \mathbb{C} \longleftrightarrow (x, y) = (\operatorname{Re} z, \operatorname{Im} z) \in \mathbb{R}^2.$$

In particular, this allows us to treat \mathbb{C} as a metric space by introducing the distance

$$d(z, w) = \sqrt{(\operatorname{Re} z - \operatorname{Re} w)^2 + (\operatorname{Im} z - \operatorname{Im} w)^2}$$

which obviously can be written as

$$d(z, w) = |z - w|$$

where $|\cdot|$ is the modulus of a complex number.

Let us write down some basic properties of the modulus $|z|$. Recall that $e^{i\theta} = \cos \theta + i \sin \theta$ when $\theta \in \mathbb{R}$. For now, we will take this as the *definition* of $e^{i\theta}$, which is more-or-less what was done in Prelims Complex Analysis. Later on, we will define the complex exponential function e^z and link the two concepts.

Lemma 0.3.1. *Let $z, w \in \mathbb{C}$. Then*

1. $|z|^2 = z\bar{z}$, where \bar{z} is the complex conjugate of z ;
2. If $z = re^{i\theta}$, where $r \in [0, \infty)$ and $\theta \in \mathbb{R}$, then $|z| = r$;
3. $|zw| = |z||w|$.

Proof. (1) If $z = a + ib$ then $z\bar{z} = (a + ib)(a - ib) = a^2 + b^2$.

(2) We have $z = r \cos \theta + ir \sin \theta$ and so

$$|z| = \sqrt{r^2 \cos^2 \theta + r^2 \sin^2 \theta} = r.$$

(3) One can calculate directly, writing $z = a + ib$ and $w = c + id$. Alternatively, write $z = re^{i\theta}$, $w = r'e^{i\alpha}$, and then observe that $zw = rr'e^{i(\theta+\alpha)}$ and use (2). \square

We will also use some basic topological notions that will be discussed more extensively in the Metric Spaces.

Definition 0.3.2. We say that $U \subset \mathbb{C}$ is *open* if for every $z \in U$ there is some $\epsilon > 0$ such that an open ball $B(z, \epsilon) := \{w \in \mathbb{C} : |z - w| < \epsilon\} \subset U$.

Any open set U containing z is called a *neighbourhood* of z .

In complex analysis, it is often convenient to work with connected open sets, and these are called domains.

Definition 0.3.3. A connected open subset $D \subseteq \mathbb{C}$ of the complex plane will be called a *domain*.

Chapter 1

Complex differentiability

Now we come to a crucial part in the course – the discussion of what it means for a function $f : \mathbb{C} \rightarrow \mathbb{C}$ to be differentiable. We begin with a quick refresher on limits, the material that may be found (in the real case) in Prelims.

Suppose that $a \in \mathbb{C}$, and that U is a neighbourhood of a . That is, U contains some ball $B(a, r)$, $r > 0$, but U itself need not be open. Suppose that $f : U \setminus \{a\} \rightarrow \mathbb{C}$ is a function: that is, f is defined on U , except not at a . Then we say that $\lim_{z \rightarrow a} f(z) = L$ if the following is true: for all $\varepsilon > 0$, there is some $\delta > 0$ such that if $0 < |z - a| < \delta$ then $|f(z) - L| < \varepsilon$ (and we assume $\delta < \eta$ so that f is defined when $|z - a| < \delta$).

Sometimes it is convenient to write f in terms of its real and imaginary parts $f(z) = u(z) + iv(z)$, where u and v are real-valued functions. From the definition of the modulus it is easy to see that $\lim_{z \rightarrow a} f(z) = L$ if and only if $\lim_{z \rightarrow a} u(z) = \operatorname{Re} L$ and $\lim_{z \rightarrow a} v(z) = \operatorname{Im} L$.

Remark 1.0.1. Similarly, $z = x + iy \rightarrow z_0 = x_0 + iy_0$ if and only if $x \rightarrow x_0$ and $y \rightarrow y_0$. But you have to be very careful with the order of limits. In general,

$$\lim_{x \rightarrow x_0, y \rightarrow y_0} f(x + iy), \quad \lim_{x \rightarrow x_0} \lim_{y \rightarrow y_0} f(x + iy) \quad \text{and} \quad \lim_{y \rightarrow y_0} \lim_{x \rightarrow x_0} f(x + iy)$$

are three different limits. If the first limit exists, then two others exist as well and have the same value, but this is the only connection.



For example, let us consider $f(z) = f(x + iy) = xy/(x + y)$ and $z_0 = 0$. It is easy to see that

$$\lim_{x \rightarrow 0} \lim_{y \rightarrow 0} f(x + iy) = \lim_{y \rightarrow 0} \lim_{x \rightarrow 0} f(x + iy) = 0$$

but

$$\lim_{z \rightarrow 0} f(z)$$

does not exist.

1.1 Complex differentiability

With the relevant notions of limit having been recalled, we can give the definition of a (complex) derivative. In fact, it is the same as the definition of real derivative, but with complex numbers in place of reals.

Definition 1.1.1 (Complex differentiability). Let $a \in \mathbb{C}$, and suppose that $f : U \rightarrow \mathbb{C}$ is a function, where $U \subset \mathbb{C}$ is an open set containing a . In particular, f is defined on some ball $B(a, r)$. Then we say that f is (complex) differentiable at a if

$$\lim_{z \rightarrow a} \frac{f(z) - f(a)}{z - a}$$

exists. If the limit exists, we write $f'(a)$ for it and call this the derivative of f at a .

Since we will be talking exclusively about functions on \mathbb{C} , we just use the terms differentiable/derivative and omit the word ‘complex’. The following lemma collects the basic facts about derivatives. We omit the proof, which is essentially identical to the real case.

Lemma 1.1.2. *Let $a \in \mathbb{C}$, let U be a neighbourhood of a and let $f, g : U \rightarrow \mathbb{C}$.*

1. (Sums, products) *If f, g are differentiable at a then $f + g$ and fg are differentiable at a and $(f + g)'(a) = f'(a) + g'(a)$, $(fg)'(a) = f'(a)g(a) + f(a)g'(a)$.*
2. (Quotients) *If f, g are differentiable at a and $g(a) \neq 0$ then f/g is differentiable at a and*

$$(f/g)'(a) = \frac{f'(a)g(a) - f(a)g'(a)}{g(a)^2}.$$

3. (Chain rule) *If U and V are open subsets of \mathbb{C} and $f : V \rightarrow U$ and $g : U \rightarrow \mathbb{C}$ are functions, where f is differentiable at $a \in V$ and g is differentiable at $f(a) \in U$, then $g \circ f$ is differentiable at a with*

$$(g \circ f)'(a) = g'(f(a))f'(a).$$

Just as in the real case, the basic rules of differentiation stated above allow one to check that polynomial functions are differentiable: using the product rule and induction one sees that z^n has derivative nz^{n-1} for all $n \geq 0$ (as a constant obviously has derivative 0, and $f(z) = z$ has derivative 1). Then by linearity it follows every polynomial is differentiable.

Just as in the real-variable case (Prelims Analysis II) one can formulate complex differentiability in the following form, which is in fact the better form to use in most instances including the proof of Lemma 1.1.2.

Lemma 1.1.3. *Let $a \in \mathbb{C}$, let U be a neighbourhood of a and let $f : U \rightarrow \mathbb{C}$. Then f is differentiable at a , with derivative $f'(a)$, if and only if we have*

$$f(z) = f(a) + f'(a)(z - a) + \varepsilon(z)(z - a),$$

where $\varepsilon(z) \rightarrow 0$ as $z \rightarrow a$.

It is an easy exercise to check that this definition is indeed equivalent to (really just a reformulation of) the previous one.

Finally, we give an important definition.

Definition 1.1.4 (Holomorphic function). Let $U \subseteq \mathbb{C}$ be an open set (for example, a domain). Let $f : U \rightarrow \mathbb{C}$ be a function. If f is complex differentiable at every $a \in U$, we say that f is *holomorphic* on U .

Sometimes one says that f is holomorphic at a point a ; this means that there is some open set U containing a on which f is holomorphic.

Remark 1.1.5. Some authors prefer to use the term *analytic* instead of holomorphic. Strictly speaking, an analytic function is a function f that is infinitely differentiable and its Taylor series converges to f . This looks like a much stronger property, but later in this course we will see that these two properties are equivalent.

This is the first time we can see something very special about complex analysis. In real analysis, there are functions that are differentiable but not twice differentiable, that are twice differentiable but not thrice etc. There are even functions that are infinitely differentiable but not analytic. So in the real analysis classes of differentiable, twice differentiable, thrice differentiable, ..., infinitely differentiable and analytic functions are all different. In complex analysis they are all the same.



1.2 Cauchy-Riemann equations

A function from \mathbb{C} to \mathbb{C} may also be thought of as a function from \mathbb{R}^2 to \mathbb{R}^2 , and it is useful to study what differentiability means in this language and compare it with our notion of complex differentiability.

Let $z_0 \in \mathbb{C}$, and let U be a neighbourhood of z_0 . Let $f : U \rightarrow \mathbb{C}$ be a function. We abuse notation and identify $\mathbb{C} \cong \mathbb{R}^2$ in the usual way, and identify z_0 with (x_0, y_0) (thus $z_0 = x_0 + iy_0$). Then (again with some abuse of notation) we may think of U as an open subset of \mathbb{R}^2 and write $f = (u, v)$, where $u, v : \mathbb{R}^2 \rightarrow \mathbb{R}$ (the letters u, v are quite traditional in this context, and sometimes we call these the *components* of f). Another way to think of this is that $f(z) = f(x + iy) = f(x, y) = u(x, y) + iv(x, y)$.

Example 1.2.1. Consider the function $f(z) = z^2$ (which is holomorphic on all of \mathbb{C}). Since $(x + iy)^2 = (x^2 - y^2) + 2ixy$, we see that the components of f are given by $u(x, y) = x^2 - y^2$, $v(x, y) = 2xy$.

In the Metric Spaces course we have defined the notion of partial derivatives of a function $u : \mathbb{R}^2 \rightarrow \mathbb{R}$

$$\partial_x u(a) := \lim_{h \rightarrow 0} \frac{u(a_1 + h, a_2) - u(a_1, a_2)}{h}$$

(if the limit exists) and

$$\partial_y u(a) := \lim_{k \rightarrow 0} \frac{u(a_1, a_2 + k) - u(a_1, a_2)}{k}.$$

It is important to note that h, k in these limits are *real*. We define partial derivatives of v in the same way.

An important fact is that if f is differentiable then these partial derivatives *do* exist, and moreover, they are subject to a constraint.

Theorem 1.2.2 (Cauchy-Riemann equations). *Let $z_0 \in \mathbb{C}$, let U be a neighbourhood of z_0 , and let $f : U \rightarrow \mathbb{C}$ be a function which is complex differentiable at z_0 . Let $u, v : \mathbb{R}^2 \rightarrow \mathbb{R}$ be the components of f . Then the four partial derivatives $\partial_x u$, $\partial_y u$, $\partial_x v$, $\partial_y v$ exist at z_0 . Moreover, we have the Cauchy-Riemann equations*

$$\partial_x u = \partial_y v, \quad \partial_x v = -\partial_y u, \tag{1.2.1}$$

$$\text{and } f'(z_0) = \partial_x u(z_0) + i\partial_x v(z_0).$$

Remark 1.2.3. By the Cauchy-Riemann equations, there are in fact four different expressions for $f'(z_0)$ using the partial derivatives.

Remark 1.2.4. The important point to take away from Theorem 1.2.2 is that a complex differentiable function is much more than simply a pair of real differentiable functions. For instance, the function $f(z) = \operatorname{Re} z$. For this function $u(x, y) = x$ and $v(x, y) = 0$. This function is as differentiable as one could wish for from the real point of view, but it is *not* a complex differentiable function since the Cauchy-Riemann equations fail to hold. Indeed, $\partial_x u = 1 \neq 0 = \partial_y v$.

Exercise 1.2.5. Use the definition of complex differentiability to verify directly that the function $f(z) = \operatorname{Re} z$ is not differentiable anywhere.

Proof. By the definition of complex differentiability

$$f'(z_0) = \lim_{z \rightarrow z_0} \frac{f(z) - f(z_0)}{z - z_0}.$$

In particular, this shows that the limit exists and is the same if we consider a particular way in which z approaches z_0 . First, we consider $z = z_0 + h$ where h is real and $h \rightarrow 0$. Then we can see that

$$\begin{aligned} f'(z_0) &= \lim_{h \rightarrow 0} \frac{u(x_0 + h, y_0) + iv(x_0 + h, y_0) - u(x_0, y_0) - iv(x_0, y_0)}{h} \\ &= \lim_{h \rightarrow 0} \frac{u(x_0 + h, y_0) - u(x_0, y_0)}{h} + i \lim_{h \rightarrow 0} \frac{v(x_0 + h, y_0) - v(x_0, y_0)}{h} \\ &= \partial_x u(z_0) + i\partial_x v(z_0). \end{aligned}$$

In the second line we used that h is real and that a limit of a complex function exists if and only if limits of its real and imaginary parts exist and are equal to the real and imaginary parts of the function's limit. In particular, this proves that $\partial_x u$ and $\partial_x v$ exist and

$$f'(z_0) = \partial_x u(z_0) + i\partial_x v(z_0).$$

Next, we consider a different way to approach z_0 . Let us consider $z = z_0 + ih$ where h is real and $h \rightarrow 0$. As before

$$\begin{aligned} f'(z_0) &= \lim_{h \rightarrow 0} \frac{u(x_0, y_0 + h) + iv(x_0, y_0 + h) - u(x_0, y_0) - iv(x_0, y_0)}{ih} \\ &= -i \lim_{h \rightarrow 0} \frac{u(x_0, y_0 + h) - u(x_0, y_0)}{h} + \lim_{h \rightarrow 0} \frac{v(x_0, y_0 + h) - v(x_0, y_0)}{h} \\ &= -i\partial_y u(z_0) + \partial_y v(z_0). \end{aligned}$$

Here, we use essentially the same argument and the fact that $1/i = -i$. This proves that $\partial_y u$ and $\partial_y v$ exist and

$$f'(z_0) = -i\partial_y u(z_0) + \partial_y v(z_0).$$

Combining two different expressions for $f'(z_0)$ we get

$$\partial_x u(z_0) + i\partial_x v(z_0) = -i\partial_y u(z_0) + \partial_y v(z_0).$$

Equating real and imaginary parts of both sides and using that the partial derivatives are real we get the Cauchy-Riemann equations. \square

There is an alternative way of proving Theorem 1.2.2 which also explains the difference between real and complex differentiability.

Alternative proof of Theorem 1.2.2. First, we show that the function f is real-differentiable. We know that complex differentiability implies that

$$f(z) = f(z_0) + f'(z_0)(z - z_0) + \epsilon(z)(z - z_0), \quad (1.2.2)$$

where $\epsilon(z) \rightarrow 0$ as $z \rightarrow z_0$. Next, we want to rewrite this expression in real terms, i.e. identifying \mathbb{C} with \mathbb{R}^2 . Writing $f'(z_0) = re^{i\theta} = r \cos \theta + ir \sin \theta$ we can rewrite the derivative term $f'(z_0)(z - z_0)$ as

$$\begin{pmatrix} r \cos \theta(x - x_0) - r \sin \theta(y - y_0) \\ r \cos \theta(y - y_0) + r \sin \theta(x - x_0) \end{pmatrix} = \begin{pmatrix} r \cos \theta & -r \sin \theta \\ r \sin \theta & r \cos \theta \end{pmatrix} \begin{pmatrix} x - x_0 \\ y - y_0 \end{pmatrix}. \quad (1.2.3)$$

Hence this term is just a linear transformation given by a simple matrix. We can see that geometrically this linear transformation is very simple. It is just a rotation by angle θ and scaling by factor r . This should not be surprising since multiplication by a complex number $re^{i\theta}$ is equivalent to multiplying the modulus by r and adding θ to the argument. This is exactly the scaling by r and rotation by θ .

Recall from the Matric Spaces course that a function $f : \mathbb{R}^2 \rightarrow \mathbb{R}^2$ is real differentiable at $z_0 = (x_0, y_0)$ if there is a linear function $L = df_{z_0} : \mathbb{R}^2 \rightarrow \mathbb{R}^2$ such that

$$f(z) = f(z_0) + L(z - z_0) + R(z)$$

where $|R(z)|/|z - z_0| \rightarrow 0$ as $z \rightarrow z_0$ and L in the standard basis (that conveniently coincide with our use of real and imaginary parts) is given by the matrix

$$\begin{pmatrix} \partial_x u(x_0, y_0) & \partial_y u(x_0, y_0) \\ \partial_x v(x_0, y_0) & \partial_y v(x_0, y_0) \end{pmatrix}$$

where $\partial_x u$, $\partial_y u$, $\partial_x v$ and $\partial_y v$ are partial derivatives of u and v .

Comparing this with formulas (1.2.2) and (1.2.3) we can see that f is indeed real differentiable, partial derivatives of u and v exist and

$$\begin{pmatrix} \partial_x u(x_0, y_0) & \partial_y u(x_0, y_0) \\ \partial_x v(x_0, y_0) & \partial_y v(x_0, y_0) \end{pmatrix} = \begin{pmatrix} r \cos \theta & -r \sin \theta \\ r \sin \theta & r \cos \theta \end{pmatrix}.$$

This immediately gives the Cauchy-Riemann equations and that $f'(z_0) = r \cos \theta + ir \sin \theta = \partial_x u(x_0, y_0) + i\partial_x v(x_0, y_0)$. \square



Remark 1.2.6 (non-examinable). The second proof sheds some light on the difference between real and complex differentiability. In both cases $f(z) - f(z_0)$ can be well approximated by a linear function. But in one case it is *real* linear and in the other case it is *complex* linear. Being complex linear is a stronger property since the set of scalars is larger. So any complex linear function is real linear, but not the other way round. A real matrix of any complex linear transformation has a very special form as in (1.2.3).

The Cauchy-Riemann equations are essentially the only requirement for complex differentiability.

Theorem 1.2.7. *Suppose that $U \subseteq \mathbb{C}$ is open and that $f : U \rightarrow \mathbb{C}$ is a function. Let the components of f be (u, v) , where $u, v : \mathbb{R}^2 \rightarrow \mathbb{R}$. Suppose that all four partial derivatives $\partial_x u, \partial_y u, \partial_x v, \partial_y v$ exist, are continuous in U , and satisfy the Cauchy-Riemann equations. Then f is holomorphic on U with derivative $\partial_x u + i\partial_x v$.*

Proof. The heavy lifting for this theorem has been done in the Metric Spaces course. Theorem 1.3.1 from the Metric Spaces lecture notes tells us that the existence of continuous partial derivatives implies that f is *real* differentiable. So for any $z_0 \in U$

$$f(z) = f(z_0) + L(z - z_0) + R(z)$$

where $L = df_{z_0}$ is a real linear transformation with the matrix (in the standard basis)

$$\begin{pmatrix} \partial_x u(x_0, y_0) & \partial_y u(x_0, y_0) \\ \partial_x v(x_0, y_0) & \partial_y v(x_0, y_0) \end{pmatrix}$$

and $|R|/|z - z_0| \rightarrow 0$. Using the Cauchy-Riemann equation it can be rewritten as

$$\begin{pmatrix} \partial_x u(x_0, y_0) & -\partial_x v(x_0, y_0) \\ \partial_x v(x_0, y_0) & \partial_x u(x_0, y_0) \end{pmatrix}.$$

As we have discussed in the second proof of Theorem 1.2.2 this matrix corresponds to the complex multiplication by $\partial_x u(x_0, y_0) + i\partial_x v(x_0, y_0)$. Hence

$$f(z) = f(z_0) + (\partial_x u(x_0, y_0) + i\partial_x v(x_0, y_0))(z - z_0) + R(z).$$

This is exactly the formula from Lemma 1.1.3 which shows that f is complex differentiable and $f'(z_0) = \partial_x u(x_0, y_0) + i\partial_x v(x_0, y_0)$. \square

The assumption that function is continuously differentiable is important. Otherwise, we could have a function such that its partial derivatives satisfy the Cauchy-Riemann ‘by coincidence’ and this is not enough to imply differentiability.

Example 1.2.8. Let $f(z) = xy/(x^2 + y^2)$ for $z \neq 0$ and define $f(0) = 0$. Then $u = f$ and $v = 0$. It is easy to see that all partial derivatives at $z_0 = 0$ vanish (since $f = 0$ along both axes) so they satisfy the Cauchy-Riemann equations there. On the other hand, this function is not differentiable at 0, it is not even continuous there.

Remark 1.2.9. Complex conjugation is a very natural and useful transformation of \mathbb{C} but it completely ruins differentiability. Let f be differentiable at z_0 and that $f'(z_0) \neq 0$. Define $g(z) = \bar{f}(z)$ and $h(z) = f(\bar{z})$. Then g is not differentiable at z_0 and h is not differentiable at \bar{z}_0 . This can be checked by direct computation of partial derivatives and checking that they do not satisfy the Cauchy-Riemann equations.

The following basic fact will be established again later in the course in a different way and in greater generality, but we will need it in this section when establishing the basic properties of the exponential function.

Lemma 1.2.10. *Suppose $f : \mathbb{C} \rightarrow \mathbb{C}$ is holomorphic and that f' is identically zero. Then f is constant.*

Proof. Let the components of f be (u, v) . By Theorem 1.2.2, the partial derivative $\partial_x u$ exists and is zero. This means that, for fixed y , the function $x \mapsto u(x, y)$ is differentiable with derivative zero. By the real-variable version of the lemma we are trying to prove (which is a simple consequence of the mean value theorem) we see that $u(x, y)$ is constant as a function of x , for fixed y . Similarly, since $\partial_y u$ exists and is zero, $u(x, y)$ is constant as a function of y , for fixed x . Therefore, for arbitrary (x, y) and (x', y') we have $u(x, y) = u(x', y) = u(x', y')$, which means that u is constant. By an identical argument, v is constant. \square

1.2.1 Wirtinger derivatives

Although we will not use them again in this course, we briefly mention another way to state the Cauchy-Riemann equations.

Definition 1.2.11. Let $f : U \rightarrow \mathbb{C}$ be a function with components (u, v) , and suppose that the partial derivatives of these exist. Then we define the

Wirtinger (partial) derivatives by

$$\partial_z f := \frac{1}{2}(\partial_x f - i\partial_y f) = \frac{1}{2}(\partial_x - i\partial_y)u + i\frac{1}{2}(\partial_x - i\partial_y)v$$

and

$$\partial_{\bar{z}} f := \frac{1}{2}(\partial_x f + i\partial_y f) = \frac{1}{2}(\partial_x + i\partial_y)u + i\frac{1}{2}(\partial_x + i\partial_y)v.$$

Lemma 1.2.12. *Let U be an open subset of \mathbb{C} and let $f: U \rightarrow \mathbb{C}$. Then f satisfies the Cauchy-Riemann equations if and only if $\partial_{\bar{z}} f = 0$, moreover, in this case $f' = \partial_z f$.*

Proof. Straightforward calculation. □



Remark 1.2.13 (Non-examinable). Wirtinger derivatives are very natural. Let us write $x = (z + \bar{z})/2$ and $y = (z - \bar{z})/(2i)$ and pretend for a second that we change the variables¹ from (x, y) to (z, \bar{z}) . Then we get Wirtinger derivatives from the change of variables formula.

Using this ‘change of variables’ any function of x and y can be written as a function of z and \bar{z} . Then the Cauchy-Riemann equation could be *informally* interpreted as the fact that f depends on z but not on \bar{z} and $f' = \partial_z f$. Although Wirtinger derivatives are *not* partial derivatives with respect to z and \bar{z} , they behave like this for all practical purposes. For example, let us consider $f(z) = x^2 + y^2 = |z|^2 = z\bar{z}$. A simple computation shows that

$$\partial_z z\bar{z} = \partial_z f = \frac{1}{2}(2x - i2y) = \bar{z}$$

and

$$\partial_{\bar{z}} z\bar{z} = \partial_{\bar{z}} f = \frac{1}{2}(2x + i2y) = z.$$

In light of this, Remark 1.2.9 becomes very natural. If f is differentiable and $g = \bar{f}$ then

$$\partial_{\bar{z}} g = \frac{1}{2}(\partial_x g + i\partial_y g) = \frac{1}{2}\overline{\partial_x f - i\partial_y f} = \overline{\partial_z f} = \bar{f}'.$$

So, unless $f' = 0$, function g is not holomorphic. On the other hand, it satisfies a different equation $\partial_z g = 0$. Such functions are called *anti-holomorphic* functions.



Finally, it is very important to remember that although this remark gives valuable intuition, it is not rigorous and can not be used in proofs.

¹This is not really true since as complex variables z and \bar{z} are not independent variables

1.3 Harmonic functions

In this brief section, we introduce the notion of a harmonic function and the relation of this concept to complex differentiability. We will return to this in much more detail later in the course.

We begin with the basic definitions.

Definition 1.3.1. Suppose that $u : \mathbb{R}^2 \rightarrow \mathbb{R}$ is a function on some open set $U \subseteq \mathbb{R}^2$ which is twice differentiable (that is, the partial derivatives themselves have partial derivatives). Then we define the *Laplacian* $\Delta u = \partial_{xx}u + \partial_{yy}u$, where $\partial_{xx}u = \partial_x(\partial_x u) = \partial_x^2 u$ and similarly for $\partial_{yy}u$.

Definition 1.3.2. Suppose that $u : \mathbb{R}^2 \rightarrow \mathbb{R}$ is a function on some open set $U \subseteq \mathbb{R}^2$ which is twice differentiable. Then we say that u is *harmonic* if $\Delta u = 0$.

The reason for introducing this notion here is the following important result.

Theorem 1.3.3. *Let $U \subseteq \mathbb{C}$ be open, and suppose that $f : U \rightarrow \mathbb{C}$ is holomorphic. Let the components of f be (u, v) , and suppose that they are both twice continuously differentiable. Then u and v are harmonic.*

Proof. From the Cauchy-Riemann equations,

$$\partial_{xx}u = \partial_{xy}v (= \partial_x \partial_y v), \quad \partial_{yy}u = -\partial_{yx}v.$$

However, one knows (Prelims) that under the stated conditions we have the symmetry property of partial derivatives

$$\partial_{xy}v = \partial_{yx}v,$$

and the result follows. □

Let us make some further comments on this result:

- We will show later in the course that a holomorphic function such as f is in fact infinitely (complex) differentiable. (This is a rather remarkable and important fact, not true at all in real-variable analysis.) Therefore the assumption that u, v be twice differentiable is automatically satisfied and can be omitted in the statement of the theorem, once one has established that result later in the course.

- The symmetry of mixed partial derivatives means that we can factorise $\Delta = (\partial_x - i\partial_y)(\partial_x + i\partial_y)$. So in terms of Wirtinger derivatives we can write $\Delta = 4\partial_z\partial_{\bar{z}}$.
- If $u, v : \mathbb{R}^2 \rightarrow \mathbb{R}$ are harmonic functions such that $f(z) = u(z) + iv(z)$ is holomorphic, we say that u and v are *harmonic conjugates*.
- [Non-examinable] It can be shown that if u is harmonic in a simply connected domain i.e. a domain without holes (we will discuss it in more detail later), then it has a harmonic conjugate v and so it is a real part of a holomorphic functions.



1.4 Power series

In this section we look at the power series of a complex variable. Much of the theory parallels the real-variable theory as seen in Prelims Analysis II and the proofs go over verbatim. For the most part we will omit them.

A (formal) power series is really just a sequence $(a_n)_{n=0}^{\infty}$ of complex numbers, but we call it a power series because we are interested in understanding $\sum_{n=0}^{\infty} a_n z^n$. *A priori*, however, this sum may not converge for even a single nonzero z ; nonetheless, it is conventional to write $\sum_{n=0}^{\infty} a_n z^n$, rather than be technically formal and correct and refer to the sequence $(a_n)_{n=0}^{\infty}$.

We say that a power series $\sum_{n=0}^{\infty} a_n z^n$ *converges* at a point z if the sequence of partial sums $\sum_{n=0}^k a_n z^n$ tends to a limit as $k \rightarrow \infty$. For such z , $\sum_{n=0}^{\infty} a_n z^n$ makes sense as an actual complex number.

Definition 1.4.1 (Radius of convergence). Let $\sum_{n=0}^{\infty} a_n z^n$ be a power series, and let S be the set of $z \in \mathbb{C}$ at which it converges. The *radius of convergence* of the power series is $\sup\{|z| : z \in S\}$, or ∞ if the set S is unbounded. Note that S is always nonempty since $0 \in S$.

The following result is mostly, but not entirely, in Prelims Analysis I. We will prove it again, albeit at a moderately high speed.

Proposition 1.4.2. *Let $\sum_{n=0}^{\infty} a_n z^n$ be a power series, let S be the subset of \mathbb{C} on which it converges and let R be its radius of convergence. Then we have*

$$B(0, R) \subseteq S \subseteq \bar{B}(0, R). \quad (1.4.1)$$

The series converges absolutely on $B(0, R)$ and if $0 \leq r < R$ then it converges uniformly on $\bar{B}(0, r)$. Moreover, we have

$$\frac{1}{R} = \limsup_n |a_n|^{1/n}. \quad (1.4.2)$$

Remark. The statement is uncontroversial when $0 < R < \infty$. Suitably interpreted, the proposition makes sense when $R = 0$ and $R = \infty$ as well, and we consider the statement to include these cases:

- When $R = 0$, one should take $B(0, R) = \emptyset$ and $\bar{B}(0, R) = \{0\}$, so (1.4.1) is the statement that $S \subseteq \{0\}$ in this case (which is trivial). Statement (1.4.2) should be taken to mean that $\limsup_n |a_n|^{1/n} = \infty$ (which is not so trivial).
- When $R = \infty$, one should take $B(0, R) = \bar{B}(0, R) = \mathbb{C}$, so (1.4.1) is the statement that $S = \mathbb{C}$. Statement (1.4.2) should be taken to mean that $\lim_{n \rightarrow \infty} |a_n|^{1/n} = 0$.

Proof. We begin with (1.4.1), which was essentially proven in Prelims. The containment $S \subseteq \bar{B}(0, R)$ is immediate from the definition of the radius of convergence (even when $R = \infty$). The other containment $B(0, R) \subseteq S$, as well as the statement that the series converges absolutely on $B(0, R)$, are both consequences of the statement that the series converges uniformly on $\bar{B}(0, r)$ when $0 \leq r < R$. This is because $B(0, R) = \bigcup_{r < R} \bar{B}(0, r)$ (this is also true when $R = \infty$).

Let us, then, prove this statement. By definition of R , there is some w , $|w| > r$, such that $\sum_{n=0}^{\infty} a_n w^n$ converges. In particular, the terms of the sum are bounded: $|a_n w^n| \leq M$ for some M . But then if $|z| \leq r$ we have

$$|a_n z^n| = |a_n w^n| \left| \frac{z}{w} \right|^n \leq M \left| \frac{r}{w} \right|^n.$$

The geometric series $\sum_n \left| \frac{r}{w} \right|^n$ converges, since $|w| > r$. Therefore, by the Weierstrass test (for series) $\sum_{n=0}^{\infty} a_n z^n$ converges uniformly for $|z| \leq r$.

Now we turn to the formula (1.4.2), which is not always covered in Prelims. Suppose the radius of convergence is R . Let $0 \leq r < R$. By the above, there is some w , $|w| > r$, such that $|a_n w^n| \leq M$ for all n . We may clearly assume that $M \neq 0$. Taking n th roots gives $|a_n|^{1/n} |w| \leq M^{1/n}$. Since $M^{1/n} \rightarrow 1$ as $n \rightarrow \infty$, this implies that $\limsup_n |a_n|^{1/n} \leq \frac{1}{|w|} < \frac{1}{r}$. Since $r < R$ was arbitrary, it follows that $\limsup_n |a_n|^{1/n} \leq \frac{1}{R}$. (This is perfectly legitimate when $R = \infty$ as well, with the interpretation that $\frac{1}{R} = 0$ in this case.)

In the other direction, suppose that $\limsup_n |a_n|^{1/n} = L$ and that $L \in (0, \infty)$. If $L' > L$, this means that $|a_n|^{1/n} \leq L'$ for all sufficiently large n . Therefore $|a_n z^n| \leq |L' z|^n$ (for sufficiently large n), and by the geometric series formula the series $\sum_n a_n z^n$ converges provided $|z| < \frac{1}{L'}$. Therefore $R \geq \frac{1}{L'}$. Since $L' > L$ was arbitrary, $R \geq \frac{1}{L}$, that is to say $\limsup_n |a_n|^{1/n} \geq \frac{1}{R}$.

The argument is valid with minimal changes when $L = 0$; we have shown that $R > \frac{1}{L'}$ for all $L' > 0$, and so $R = \infty$, and so the inequality $\limsup_n |a_n|^{1/n} \geq \frac{1}{R}$ remains true (with the interpretation discussed above).

When $L = \infty$, the inequality is vacuously true. Putting all this together concludes the proof. \square

The next lemma is about sums and products of power series.

Lemma 1.4.3. *Let $\sum_{n=0}^{\infty} a_n z^n$ and $\sum_{n=0}^{\infty} b_n z^n$ be power series with radii of convergence R_1 and R_2 respectively. For $|z| < \min(R_1, R_2)$, write $s(z), t(z)$ for the functions to which these series converge.*

1. *The power series $\sum_{n=0}^{\infty} (a_n + b_n) z^n$ converges in $|z| < \min(R_1, R_2)$, to $s(z) + t(z)$.*
2. *The power series $\sum_{n=0}^{\infty} (\sum_{k+l=n} a_k b_l) z^n$ converges in $|z| < \min(R_1, R_2)$, to $s(z)t(z)$.*

Proof. See Prelims Analysis I Problem Sheet 7 (for the real variable case; the complex case is the same). Note that $\min(R_1, R_2)$ is only a lower bound for the radius of convergence in each case – it is easy to find examples where the actual radius of convergence of the sum or product is strictly larger than this. \square

Next, we differentiate power series term by term.

Proposition 1.4.4 (Differentiation of power series). *Let $\sum_{n=0}^{\infty} a_n z^n$ be a power series, with the radius of convergence R . Let $s(z)$ be the function to which this series converges on $B(0, R)$. Then power series $t(z) = \sum_{n=1}^{\infty} n a_n z^{n-1}$ also has radius of convergence R and on $B(0, R)$ the power series s is complex differentiable with $s'(z) = t(z)$. In particular, a power series is infinitely complex-differentiable within its radius of convergence.*

Proof. This is proved in the real variable case Prelims Analysis II (see Theorem 8.16 in the current lecture notes); the proof adapts to the complex case with trivial changes. \square

1.4.1 Power series about other points

We conclude with some remarks about power series about points z_0 other than 0, which come up frequently in complex analysis.

Such power series are functions given by an expression of the form

$$f(z) = \sum_{n=0}^{\infty} a_n (z - z_0)^n.$$

All the results we have shown above immediately extend to these more general power series, since if

$$g(z) = \sum_{n=0}^{\infty} a_n z^n,$$

then the function f is obtained from g simply by composing with the translation $z \mapsto z - z_0$. In particular, the chain rule shows that

$$f'(z) = \sum_{n=1}^{\infty} n a_n (z - z_0)^{n-1}.$$

Remark 1.4.5. Let $f(z) = \sum_{n=0}^{\infty} a_n (z - z_0)^n$ be a function given by a power series with positive radius of convergence R . Since the radius of convergence for the derivative $f'(z) = \sum n a_n (z - z_0)^{n-1}$ is at least $R > 0$, it shows that f' is also holomorphic in $B(z_0, R)$. By induction, all derivatives of f . Moreover, $f(z_0) = a_0$, $f'(z_0) = a_1$, etc, so



$$f(z) = \sum_{n=0}^{\infty} \frac{f^{(n)}(z_0)}{n!} (z - z_0)^n,$$

so f is given by its Taylor series. Such functions are called *analytic*. Theorem 1.4.4 proves that analytic functions are holomorphic. Later in the course we will see that all holomorphic functions are analytic.

1.4.2 The exponential and trigonometric functions

With the basic facts about complex power series under our belt, we can define some of the most important functions in mathematics as functions of a complex variable.

Example 1.4.6. The functions

$$e^z = \exp(z) = \sum_{n=0}^{\infty} \frac{z^n}{n!},$$

$$\cos(z) = \sum_{n=0}^{\infty} (-1)^n \frac{z^{2n}}{(2n)!},$$

and

$$\sin(z) = \sum_{n=0}^{\infty} (-1)^n \frac{z^{2n+1}}{(2n+1)!}$$

are all holomorphic on all of \mathbb{C} and their derivatives are given by term-by-term differentiation of the series. In particular,

$$\exp' = \exp, \quad \cos' = -\sin, \quad \sin' = \cos.$$

Also

$$e^{iz} = \exp(iz) = \cos z + i \sin z.$$

Clearly, when z is real these formulas coincide with definitions of real \exp , \sin and \cos from Prelims. This is a very natural way to extend a function from \mathbb{R} to \mathbb{C} . Not all functions that are infinitely differentiable in \mathbb{R} can be extended to the complex plane.



Example 1.4.7. Consider $f(x) = 1/(1+x^2)$. This is a perfectly nice real function. It is real analytic and for every $x_0 \in \mathbb{R}$ there is $r = r(x_0) > 0$ such that the Taylor series of f at x_0 converges to f in $B(x_0, r)$. In particular, these power series can be used to extend f to some region in \mathbb{C} . Of course, in this particular case, there is a much simpler way to extend our function: we can just write $f(z) = 1/(1+z^2)$. This function is well defined and holomorphic in $\mathbb{C} \setminus \{i, -i\}$



Remark 1.4.8 (Non-examinable). Sometimes, extensions are not so simple and it is not obvious that there is a natural *maximal* domain where the extension exists and that extensions are unique. There is a rich and important theory of analytic extensions, but it is beyond the scope of this course.



Example 1.4.9 (Non-examinable). One of the most important examples of analytic extension is the Riemann zeta function. For real $x > 1$ we define

$$\zeta(x) = \sum_{n=1}^{\infty} \frac{1}{n^x}.$$



It is a standard fact that this series converges for all $x > 1$. With a little bit of work² one can show that this series converges if we replace x by a complex number z with $\operatorname{Re} z > 1$. This is not a power series, so it is not obvious that ζ is holomorphic, but it can be shown that it is. Riemann has shown that this function can be analytically extended to $\mathbb{C} \setminus \{1\}$.

1.4.3 Properties of exponential and trigonometric functions

From the definition we can immediately see that

$$\sin(-z) = -\sin z, \quad \cos(-z) = \cos z$$

and so

$$\cos z = \frac{e^{iz} + e^{-iz}}{2}, \quad \sin z = \frac{e^{iz} - e^{-iz}}{2i}.$$

We can also see that hyperbolic sine and cosine are very closely related to sine and cosine. They all defined by similar formulas in terms of \exp , the only difference is in the factor i .

We can also properly understand Euler's formula $e^{i\theta} = \cos \theta + i \sin \theta$ for $\theta \in \mathbb{R}$. Note also that

The exponential function also satisfies the following extremely important property.

Proposition 1.4.10. *We have $\exp(z + w) = \exp(z) \exp(w)$.*

Proof. Fix $a \in \mathbb{C}$, and consider the function $f(z) = \exp(z) \exp(a - z)$. Differentiating and using the product rule and chain rule, we see that

$$f'(z) = \exp(z) \exp(a - z) - \exp(z) \exp(a - z) = 0.$$

Therefore, by Lemma 1.2.10, f is constant. It follows that

$$f(z) = f(0) = \exp(a),$$

that is to say

$$\exp(z) \exp(a - z) = \exp(a).$$

Substituting $a = z + w$ gives the stated result. \square

Corollary 1.4.11. *For $x, y \in \mathbb{R}$ we have $e^{x+iy} = e^x(\cos y + i \sin y)$.*

²In particular, we have not yet defined what n^z means for complex z

1.4.4 Logarithms and powers

There are several ways to define the real logarithm, but arguably the most natural one is to say that \log is the inverse of \exp . Since in the real case \exp is a monotone function that maps $(-\infty, \infty)$ to $(0, \infty)$, the logarithm is uniquely defined for all positive real numbers.

In \mathbb{C} things become immediately more complicated. From Corollary 1.4.11 we can see that the range of \exp is $\mathbb{C} \setminus \{0\}$, but the function is not one-to-one. If $e^w = z$ then $e^{w+2\pi in} = z$ for any $n \in \mathbb{Z}$. In other words, if z has a logarithm then it has infinitely many³. It turns out that there is no canonical choice of logarithm and, worse still, there is no way to define the logarithm as a holomorphic function on all of $\mathbb{C} \setminus \{0\}$. We will pay closer attention to these points in the coming lectures, but for now we record the following positive results.

The good news is that Corollary 1.4.11 gives us a way to solve the equation $\exp(w) = z$. By writing $w = u + iv$ and $z = |z|(\cos \theta + i \sin \theta)$ we get

$$e^w = e^u(\cos(v) + i \sin(v)) = r(\cos \theta + i \sin \theta) = z$$

This implies $\exp(u) = |z|$, $\cos(v) = \cos \theta$ and $\sin(v) = \sin \theta$. Since u is real we must have $u = \log |z|$ and the last two equations imply that that $v - \theta$ must be an integer multiple of 2π .

At this point, there are two possible ways to continue. One is to accept that the equation $\exp(w) = z$ has infinitely many solutions and define the logarithm as a multifunction (this is like a function but it could have many values) or to choose one of the solutions and to declare it to be the ‘right one’. We will explore both possibilities but we will start with the second one.

First, we will need a simple version of the Inverse Function Theorem. Later in this course, we will have the full version.

Proposition 1.4.12 (Simplified Inverse function Theorem). *Let $f : U \rightarrow \mathbb{C}$ be a holomorphic function. Let z_0 be a point in U and assume that there is $V \subset U$ containing z_0 such that f is one-to-one on $V \rightarrow f(V) = W$ and the inverse function $g = f^{-1} : W \rightarrow V$ is continuous. Then g is differentiable at $w_0 = f(z_0)$ and $g'(w_0) = 1/f'(z_0)$.*

Remark 1.4.13. The main difference with the usual inverse function theorem is that here we assume the existence and continuity of the inverse function.

³This is exactly the same problem that we encounter trying to define \sin^{-1} and \cos^{-1} in \mathbb{R} .





In Prelims we have shown that if $f(x)$ is continuously differentiable and $f'(x_0) \neq 0$, then f is locally monotone and this almost immediately implied that f is locally invertible and the inverse is continuous. The main problem is that \mathbb{C} can not be ordered and monotonicity makes no sense. Eventually, we will overcome this problem, but it will happen much later in this course. The good news is that for many functions it is not too difficult to prove that the inverse exists and is continuous, so Proposition 1.4.12 gives that the inverse is holomorphic.

Proof. The proof is straightforward and essentially the same as in Prelims. Let us consider $f(z) = w \rightarrow w_0 = f(z_0)$ and write

$$\frac{g(w) - g(w_0)}{w - w_0} = \frac{z - z_0}{f(z) - f(z_0)} \rightarrow \frac{1}{f'(z_0)}.$$

Here we used that $z \rightarrow z_0$ which follows from the continuity of g . \square

Proposition 1.4.14. *Slightly abusing notations we define $D = \mathbb{C} \setminus (-\infty, 0]$. That is, D is the complex plane minus the negative real axis (and 0). Define the function $\text{Log} : D \rightarrow \mathbb{C}$ as follows: if $z = |z|e^{i\theta}$ with $\theta \in (-\pi, \pi]$ then set*

$$\text{Log}(z) := \log |z| + i\theta.$$

Then Log is holomorphic on D and

$$\text{Log}'(z) = \frac{1}{z}.$$

Remark 1.4.15. It might look like a circular argument since we define Log in terms of \log . But in fact, \log is a *real* function that we have defined in Prelims. So essentially, we define the complex logarithm in terms of the real logarithm.



Definition 1.4.16. The values $\theta \in (-\pi, \pi]$ such that $z = |z|e^{i\theta}$ is called the *principal value* of the argument of z and the function Log defined in Proposition 1.4.14 is called the *principal value* of the logarithm.

Remark 1.4.17. The notation Log is not universal. Many authors use \log for all versions of the logarithm. We will always use Log for the principal value and other notations for other versions.

Proof of Proposition 1.4.14. We are going to apply Proposition 1.4.12 and in order to do so we just have to show that Log is a continuous inverse of \exp . It is an inverse by construction, so we just need to prove continuity.

We know that $|z|$ and \log are continuous, so the real part of Log is continuous, so it remains to show that the argument $\theta = \theta(z)$ is a continuous function of z .

By the law of cosines

$$\cos(\theta(z+h) - \theta(z)) = \frac{|z|^2 + |z+h|^2 - |h|^2}{2|z||z+h|}.$$

It is easy to see that for all $|z| > 0$ this converges to 1 as $h \rightarrow 0$. Since $z \in D$ and $\theta \in (-\pi, \pi)$ this implies that $\theta(z+h) \rightarrow \theta(z)$. This completes the proof that Log is continuous.

Note, that it is important that we exclude the negative real line from D . If we were to include it and define the argument to be π there, then θ would not be continuous. For example, $\theta(-1) = \pi$ but $\theta(-1-i\epsilon) \rightarrow -\pi$ as $\epsilon \rightarrow 0+$.



By Proposition 1.4.12 Log is differentiable and its inverse is $1/\exp'(\text{Log}(z)) = 1/\exp(\text{Log}(z)) = 1/z$. Since this argument works for any $z \in D$, this proves that Log is holomorphic in D and its derivative is $1/z$. \square

Remark 1.4.18. This argument is essentially the same as the proof of the Inverse Function Theorem from Prelims. In a similar way one can prove a complex version of this theorem. The main difficulty is in proving that if $f' \neq 0$ then the function locally is one-to-one and there is a local inverse. In Prelims, we have used monotonicity for this, but complex numbers are not ordered and there is no way to generalise this argument. The result is still correct, but we will not prove it here.

Remark 1.4.19. There is yet another possibility to prove that Log is holomorphic. We can write $\text{Log} = u + iv$ where $u = (1/2)\log(x^2 + y^2)$ and $v = \arctan(y/x)$ and check that u and v are continuously differentiable and satisfy the Cauchy-Riemann equations. Then, by Theorem 1.2.7, Log is holomorphic. The downside is that the expression for v is correct only for $x > 0$, for other parts of D one has to write other similar expressions. This argument is not very difficult, but has too many technicalities.

Remark 1.4.20. Finally, there is a completely different approach to the definition of complex logarithm. As in \mathbb{R} we can define the logarithm as the integral of $\int_1^z 1/w dw$, but this requires the notion of the integral and there are other subtleties so we do not use this approach. On the other hand, by the end of this course you will see that this approach makes perfect sense.

Since we now have a version of the logarithm, we can define complex powers as well:

Definition 1.4.21. Let $\alpha, z \in \mathbb{C}$ and $z \neq 0$. Then we define the *principal value* of z^α as $\exp(\alpha \operatorname{Log}(z))$.

It is important to note that these versions of the logarithm and power inherit many properties from their real counterparts, but not all of them. For example



$$\operatorname{Log}(e^{4\pi i/3}) = \operatorname{Log}(e^{-2\pi i/3}) = \frac{-2\pi i}{3} \neq \frac{4\pi i}{3} = \operatorname{Log}(e^{2\pi i/3}) + \operatorname{Log}(e^{2\pi i/3}).$$

Similarly,

$$\sqrt{\frac{1}{-1}} = \sqrt{-1} = i \neq -i = \frac{1}{i} = \frac{\sqrt{1}}{\sqrt{-1}}.$$

1.5 Branch cuts and multifunctions

Many functions like logarithm, roots, and inverse trigonometric functions are defined as functions that are inverse of functions that are not injective. So, potentially, they could have many values. On the other hand, our definition of a function does not allow this. One way to overcome this issue is to extend the definition.

Definition 1.5.1. A *multi-valued function* or *multifunction* on a subset $U \subseteq \mathbb{C}$ is a map $f: U \rightarrow \mathcal{P}(\mathbb{C})$ assigning to each point in U a subset⁴ of the complex numbers.

Sometimes, like in the previous section with the principal value of the logarithm or when we choose the positive square root of a positive real number, we would like to make a unique choice of a value. This is formalized in the following definition:

Definition 1.5.2. Let $f: U \rightarrow \mathcal{P}(\mathbb{C})$ be a multifunction. A *branch* of f on a subset $V \subseteq U$ is a function $g: V \rightarrow \mathbb{C}$ such that $g(z) \in f(z)$, for all $z \in V$. If g is continuous (or holomorphic) on V we refer to it as a continuous, (respectively holomorphic) branch of f .

Definition 1.5.3. Suppose that $f: U \rightarrow \mathcal{P}(\mathbb{C})$ is a multi-valued function defined on an open subset U of \mathbb{C} . We say that $z_0 \in U$ is not a branch point of f if there is an open disk⁵ $D \subseteq U$ containing z_0 such that there is

⁴We use the notation $\mathcal{P}(X)$ to denote the *power set* of X , that is, the set of all subsets of X .

⁵In fact any simply connected domain – see our discussion of the homotopy form of Cauchy’s theorem.

a holomorphic branch of f defined on $D \setminus \{z_0\}$. We say z_0 is a *branch point* otherwise. When $\mathbb{C} \setminus U$ is bounded, we say that f does not have a branch point at ∞ if there is a holomorphic branch of f defined on $\mathbb{C} \setminus B(0, R) \subseteq U$ for some $R > 0$. Otherwise, we say that ∞ is a branch point of f .

Branch cut for a multifunction f is a collection of curves in the plane on whose complement we can pick a holomorphic branch of f . Thus branch cuts must contain all the branch points.

Remark 1.5.4. In order to distinguish between multifunctions and functions, it is sometimes useful to introduce some notation: if we wish to consider $z \mapsto z^{1/2}$ as a multifunction, then to emphasize that we mean a multifunction we will write $[z^{1/2}]$. Thus $[z^{1/2}] = \{w \in \mathbb{C} : w^2 = z\}$. Similarly we write $[\log(z)] = \{w \in \mathbb{C} : e^w = z\}$. This is not a uniform convention in the subject, quite often depending on the context $z^{1/2}$ might be a multifunction or a branch of a multifunction or even the ‘main’ branch.

Example 1.5.5. Consider the square root ‘function’ $f(z) = z^{1/2}$. Unlike the case of real numbers, every complex number has a square root, but just as for the real numbers, there are two possibilities unless $z = 0$. Indeed if $z = x + iy$ and $w = u + iv$ has $w^2 = z$ we see that

$$u^2 - v^2 = x; \quad 2uv = y,$$

and so

$$u^2 = \frac{x + \sqrt{x^2 + y^2}}{2}, \quad v^2 = \frac{-x + \sqrt{x^2 + y^2}}{2}.$$

where the requirement that u^2, v^2 are non-negative determines the signs. Hence taking square roots we obtain the two possible solutions for w satisfying $w^2 = z$. (Note it looks like there are four possible sign combinations in the above, however the requirement that $2uv = y$ means the sign of u determines that of v .) In polars it looks simpler: if $z = re^{i\theta}$ then $w = \sqrt{r}e^{i\theta/2}$. The tricky part is that we have to consider *all* possible values of θ . Note that if θ is some possible value of the argument, then all other possible values are of the form $\theta + 2\pi n$, $n \in \mathbb{Z}$, so all possible values of w are $\sqrt{r}e^{i\theta/2}e^{i\pi n}$. The last factor takes one of two values 1 and -1 depending on whether n is even or odd. So all solutions are $\pm\sqrt{r}e^{i\theta/2}$.

To make this a single-valued function we have to make a choice of θ . For example, we can do it by requiring $\theta \in [0, 2\pi)$. This creates a branch in \mathbb{C} , but it is discontinuous along $[0, \infty)$. On the other hand, it is continuous and in fact holomorphic in a smaller domain $D = \mathbb{C} \setminus [0, \infty)$. In this case $[0, \infty)$ is the corresponding branch cut.





Example 1.5.6. Another important example of a multi-valued function which we have already discussed is the complex logarithm: as a multifunction we have $[\text{Log}(z)] = \{\log(|z|) + i(\theta + 2n\pi) : n \in \mathbb{Z}\}$ where $z = |z|e^{i\theta}$. It is important to note, that θ is not defined uniquely, there are many possible values of θ such that $z = |z|e^{i\theta}$, but they all different by integer multiples of 2π , so the set of values $[\text{Log}(z)]$ does not depend on the choice of θ . To obtain a branch of the multifunction we must make a choice of argument function $\arg: \mathbb{C} \rightarrow \mathbb{R}$ which is continuous in some (smaller) domain D . Given this choice, we may define a branch

$$\text{Log}(z) = \log(|z|) + i \arg(z), \quad z \in D$$

which is a continuous function in D . This is exactly how we have constructed the principal value of the logarithm in Proposition 1.4.14. It corresponds to the branch cut $[-\infty, 0]$.

Instead, we can choose θ differently, for example, $\theta \in [0, 2\pi)$. This could correspond to a branch cut $[0, \infty)$ and the corresponding branch of the logarithm will be holomorphic in $D = \mathbb{C} \setminus [0, \infty)$. The proof of holomorphicity of this branch is exactly the same as the proof of Proposition 1.4.14.

Example 1.5.7. Another important class of examples of multifunctions are the *complex power* multifunctions $z \mapsto [z^\alpha]$ where $\alpha \in \mathbb{C}$: These are given by

$$z \mapsto \exp(\alpha \cdot [\log(z)]) = \{\exp(\alpha \cdot w) : w \in \mathbb{C}, e^w = z\}$$

Note this includes the square root multifunction we discussed above, which can be defined without the use of the exponential function. Indeed if $\alpha = m/n$ is rational, $m \in \mathbb{Z}, n \in \mathbb{Z}_{>0}$, then $[z^\alpha] = \{w \in \mathbb{C} : w^m = z^n\}$. For $\alpha \in \mathbb{C} \setminus \mathbb{Q}$ however, we can only define $[z^\alpha]$ using the exponential function. Clearly from its definition, anytime we choose a branch $L(z)$ of $[\log(z)]$ we obtain a corresponding branch $\exp(\alpha \cdot L(z))$ of $[z^\alpha]$. If we pick $L(z)$ to be the principal branch of $[\log(z)]$, then the corresponding branch of $[z^\alpha]$ is called the *principal branch* of $[z^\alpha]$.

Multivalued logarithm and power functions share a lot of nice properties with their real counterparts.

Proposition 1.5.8. For $\alpha, z, w \in \mathbb{C}$ with $z, w \neq 0$

$$[\log z] + [\log w] = [\log zw],$$

and

$$[z^\alpha][w^\alpha] = [(zw)^\alpha].$$

Proof. Let θ and ϕ be some values of $\arg(z)$ and $\arg(w)$, then $[\log z] = \{\log |z| + i\theta + 2\pi in, n \in \mathbb{Z}\}$ and $[\log w] = \{\log |w| + i\phi + 2\pi ik, k \in \mathbb{Z}\}$. Adding two sets term-by-term we get

$$\begin{aligned} [\log z] + [\log w] &= \{\log |z| + \log |w| + i(\theta + \phi) + 2\pi i(k + n), k, n \in \mathbb{Z}\} \\ &= \{\log |zw| + i(\theta + \phi) + 2\pi im, m \in \mathbb{Z}\} = [\log(zw)]. \end{aligned}$$

Similarly,

$$\begin{aligned} [z^\alpha] &= \{|z|^\alpha \exp(i\alpha\theta + i\alpha 2\pi in)\} \\ [w^\alpha] &= \{|w|^\alpha \exp(i\alpha\phi + i\alpha 2\pi ik)\} \end{aligned}$$

and multiplying them term-by-term we get

$$\begin{aligned} [z^\alpha][w^\alpha] &= \{|zw|^\alpha \exp(i\alpha(\theta + \phi) + i\alpha 2\pi i(n + k)), k, n \in \mathbb{Z}\} \\ &= \{|zw|^\alpha \exp(i\alpha(\theta + \phi) + i\alpha 2\pi im), m \in \mathbb{Z}\} = [(zw)^\alpha]. \end{aligned}$$

□



Remark 1.5.9. Not all properties of real functions are valid for complex multifunctions. For example, in general,

$$[z^\alpha][z^\beta] \neq [z^{\alpha+\beta}].$$

This can be seen by considering

$$[1^{1/2}][1^{1/2}] = \{-1, 1\}\{-1, 1\} = \{-1, 1\} \neq \{1\} = [1^1].$$

Some operations with multifunctions are a bit counter-intuitive, so one has to be very careful. One such example is given by the following exercise.

Exercise 1.5.10. Let z be any non-zero complex number. Then $[\log(-z)^2] = [\log z^2]$, by Proposition 1.5.8 this implies $[\log(-z)] + [\log(-z)] = [\log z] + [\log z]$, so $2[\log(-z)] = 2[\log z]$ and $[\log(-z)] = [\log z]$.

The last conclusion is clearly wrong since

$$\begin{aligned} [\log z] &= \{\log |z| + i\theta + 2\pi ik, k \in \mathbb{Z}\} \\ [\log(-z)] &= \{\log |z| + i\theta + \pi i + 2\pi ik, k \in \mathbb{Z}\}. \end{aligned}$$



Where is a mistake in this argument?

Example 1.5.11. Let $F(z)$ be the multi-function

$$[(1+z)^\alpha] = \{\exp(\alpha \cdot w) : w \in \mathbb{C}, \exp(w) = 1+z\}.$$

Using $\text{Log}(z)$ the principal branch of $[\log(z)]$ we obtain a branch $f(z)$ of $[(1+z)^\alpha]$ given by $f(z) = \exp(\alpha \cdot \text{Log}(1+z))$. Define

$$\binom{\alpha}{k} = \frac{1}{k!} \alpha \cdot (\alpha - 1) \dots (\alpha - k + 1).$$

We want to show that a version of the binomial theorem holds for this branch of the multifunction $[(1+z)^\alpha]$. Let

$$s(z) = \sum_{k=0}^{\infty} \binom{\alpha}{k} z^k,$$

By the ratio test, $s(z)$ has a radius of convergence equal to 1, so that $s(z)$ defines a holomorphic function in $B(0, 1)$. Moreover, you can check using the properties of power series established in a previous section, that within $B(0, 1)$, $s(z)$ satisfies $(1+z)s'(z) = \alpha \cdot s(z)$.

Now $f(z)$ is defined on $\mathbb{C} \setminus (-\infty, -1)$, and hence on all of $B(0, 1)$. Moreover $f'(z) = \alpha f(z)/(1+z)$. We claim that within the open ball $B(0, 1)$ the power series $s(z) = \sum_{n=0}^{\infty} \binom{\alpha}{k} z^k$ coincides with $f(z)$. Indeed if we set

$$g(z) = s(z)/f(z)$$

then $g(z)$ is holomorphic for every $z \in B(0, 1)$ since f never vanishes in the unit disc. Clearly

$$g'(z) = (s'(z)f(z) - f'(z)s(z))/f^2(z) = 0$$

since $s'(z) = \frac{\alpha \cdot s(z)}{1+z}$ and $f'(z) = \frac{\alpha \cdot f(z)}{1+z}$. Also $g(0) = 1$ so g is constant and $s(z) = f(z)$.

Here we use the fact that if a holomorphic function g has $g'(z) = 0$ on $B(0, 1)$ then it is constant. We have already proven this for \mathbb{C} and in fact the same proof applies to $B(0, 1)$. Indeed, as we saw in the case of \mathbb{C} , if $g'(z) = 0$ for all z then g is constant on any vertical and horizontal segment, which clearly implies that g is constant on $B(0, 1)$. We note that this follows also from the following general result that we will prove soon: if a holomorphic function g has $g'(z) = 0$ for all z in a domain U , then g is constant on U .

Example 1.5.12. A more interesting example is the function $f(z) = [(z^2 - 1)^{1/2}]$. Using the principal branch of the square root function, we obtain a branch f_1 of f on the complement of $E = \{z \in \mathbb{C} : z^2 - 1 \in (-\infty, 0]\}$, which one calculates is equal to $[-1, 1] \cup i\mathbb{R}$.

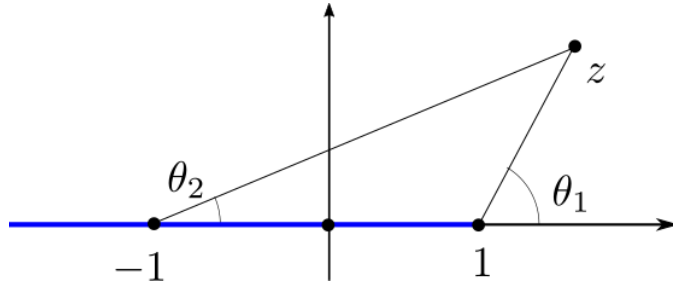
Figure 1.1: Defining the root of $z^2 - 1$.

Another approach is to write $[(z^2 - 1)^{1/2}] = [(z - 1)^{1/2}][(z + 1)^{1/2}]$ and to define branches of both factors. For both factors we will use the branch of $z^{1/2}$ with the branch cut $(-\infty, 0]$ which corresponds to using $\arg(z) \in (-\pi, \pi)$. This gives the branch

$$f(z) = |z - 1|^{1/2}|z + 1|^{1/2} \exp(i\theta_1/2) \exp(i\theta_2/2)$$

where θ_1 and θ_2 are arguments of $z - 1$ and $z + 1$ (see Figure 1.5.12). The first factor uses the branch cut $(-\infty, 1]$ and the second $(-\infty, -1]$, so the product has a branch cut $(-\infty, 1]$.

However let us examine the behaviour of the product: If z crosses the real axis at $\operatorname{Re}(z) < -1$, then θ_1 and θ_2 both jump by 2π , so that $(\theta_1 + \theta_2)/2$ jumps by 2π , and hence $\exp(i(\theta_1 + \theta_2)/2)$ is in fact continuous. On the other hand, if we cross the segment $(-1, 1)$ then only the factor $\sqrt{z - 1}$ switches sign, so our branch is discontinuous there. In a sense this means that jumps across $(-\infty, -1)$ cancel out and so the branch is continuous and holomorphic outside of the cut $[-1, 1]$.

Chapter 2

Paths and Integration

Paths will play a crucial role in our development of the theory of complex differentiable functions. In this section, we review the notion of a path and define the integral of a continuous function along a path.

2.1 Paths

Recall that a *path* in the complex plane is a continuous function $\gamma: [a, b] \rightarrow \mathbb{C}$. A path is said to be *closed* if $\gamma(a) = \gamma(b)$. The image of a path γ is

$$\{z \in \mathbb{C} : z = \gamma(t), \text{ some } t \in [a, b]\}.$$

In many cases, we will abuse notations and denote the image by γ as well. Usually, the meaning is clear from the context. In a few cases where it is important to distinguish between the path and its image, we will denote the image by γ^* .

Although for some purposes it suffices to assume that γ is continuous, in order to make sense of the integral along a path we will require our paths to be (at least piecewise) differentiable. We thus need to define what we mean for a path to be differentiable:

Definition 2.1.1. We will say that a path $\gamma: [a, b] \rightarrow \mathbb{C}$ is *differentiable* if its real and imaginary parts are differentiable as real-valued functions. Equivalently, γ is differentiable at $t_0 \in [a, b]$ if

$$\lim_{t \rightarrow t_0} \frac{\gamma(t) - \gamma(t_0)}{t - t_0}$$

exists, and then we denote this limit as $\gamma'(t_0)$. (If $t = a$ or b then we interpret the above as a one-sided limit.) We say that a path is C^1 if it is differentiable and its derivative $\gamma'(t)$ is continuous.

We will say a path is *piecewise C^1* if it is continuous on $[a, b]$ and the interval $[a, b]$ can be divided into subintervals on each of which γ is C^1 . That is, there is a finite sequence $a = a_0 < a_1 < \dots < a_m = b$ such that $\gamma|_{[a_i, a_{i+1}]}$ is C^1 . Thus in particular, the left-hand and right-hand derivatives of γ at a_i ($1 \leq i \leq m - 1$) may not be equal.

For any path $\gamma: [a, b] \rightarrow \mathbb{C}$ we define the *opposite* path γ^- by $\gamma^-: [0, b - a] \rightarrow \mathbb{C}$, $\gamma^-(t) = \gamma(b - t)$. As we will see later, integration is independent of a particular parametrization. This means that for the purpose of this course we can use any other version as long as it produces the opposite orientation. Other standard choices are $\gamma(b + a - t)$ on $[a, b]$ and $\gamma(ta + (1 - t)b)$ on $[0, 1]$.

If $\gamma_1: [a, b] \rightarrow \mathbb{C}$ and $\gamma_2: [c, d] \rightarrow \mathbb{C}$ are two paths such that $\gamma_1(b) = \gamma_2(c)$ then they can be *concatenated* to give a path $\gamma_1 \star \gamma_2$ which traverses first γ_1 and then γ_2 . Formally $\gamma_1 \star \gamma_2: [a, b + d - c] \rightarrow \mathbb{C}$ where

$$\gamma_1 \star \gamma_2(t) = \begin{cases} \gamma_1(t), & t \leq b \\ \gamma_2(t - b + c), & t \geq b \end{cases}$$

So a piecewise C^1 path is precisely a finite concatenation of C^1 paths.

Remark 2.1.2. Note that a C^1 path may not have a well-defined tangent at every point: if $\gamma: [a, b] \rightarrow \mathbb{C}$ is a path and $\gamma'(t) \neq 0$, then the line $\{\gamma(t) + s\gamma'(t) : s \in \mathbb{R}\}$ is tangent to γ^* , however, if $\gamma'(t) = 0$, the image of γ may have no tangent line there. Indeed consider the example of $\gamma: [-1, 1] \rightarrow \mathbb{C}$ given by

$$\gamma(t) = \begin{cases} t^2 & -1 \leq t \leq 0 \\ it^2 & 0 \leq t \leq 1. \end{cases}$$

Since $\gamma'(0) = 0$ the path is C^1 , even though it is clear there is no tangent line to the image of γ at 0. This shows that the image of a C^1 path can have a ‘corner’.

If $s: [a, b] \rightarrow [c, d]$ is a differentiable map, then we have the following version of the chain rule, which is proved in exactly the same way as the real-valued case. It will be crucial in our definition of the integral of functions $f: \mathbb{C} \rightarrow \mathbb{C}$ along paths.

Lemma 2.1.3. *Let $\gamma: [c, d] \rightarrow \mathbb{C}$ and $s: [a, b] \rightarrow [c, d]$ and suppose that s is differentiable at t_0 and γ is differentiable at $s_0 = s(t_0)$. Then $\gamma \circ s$ is differentiable at t_0 with derivative*

$$(\gamma \circ s)'(t_0) = s'(t_0) \cdot \gamma'(s(t_0)).$$

Proof. Let $\epsilon: [c, d] \rightarrow \mathbb{C}$ be given by $\epsilon(s_0) = 0$ and

$$\gamma(x) = \gamma(s_0) + \gamma'(s_0)(x - s_0) + (x - s_0)\epsilon(x),$$

(so that this equation holds for all $x \in [c, d]$), then $\epsilon(x) \rightarrow 0$ as $x \rightarrow s_0$ by the definition of $\gamma'(s_0)$, i.e. ϵ is continuous at t_0 . Substituting $x = s(t)$ into this we see that for all $t \neq t_0$ we have

$$\frac{\gamma(s(t)) - \gamma(s_0)}{t - t_0} = \frac{s(t) - s(t_0)}{t - t_0} (\gamma'(s(t)) + \epsilon(s(t))).$$

Now $s(t)$ is continuous at t_0 since it is differentiable there hence $\epsilon(s(t)) \rightarrow 0$ as $t \rightarrow t_0$, thus taking the limit as $t \rightarrow t_0$ we see that

$$(\gamma \circ s)'(t_0) = s'(t_0)(\gamma'(s_0) + 0) = s'(t_0)\gamma'(s(t_0)),$$

as required. □

Definition 2.1.4. Let $\phi: [a, b] \rightarrow [c, d]$ be continuously differentiable with $\phi(a) = c$ and $\phi(b) = d$, and let $\gamma: [c, d] \rightarrow \mathbb{C}$ be a C^1 -path, then setting $\tilde{\gamma} = \gamma \circ \phi$, by Lemma 2.1.3 we see that $\tilde{\gamma}: [a, b] \rightarrow \mathbb{C}$ is again a C^1 -path with the same image as γ and we say that $\tilde{\gamma}$ is a *reparametrization* of γ .

Definition 2.1.5. We will say two parametrized paths $\gamma_1: [a, b] \rightarrow \mathbb{C}$ and $\gamma_2: [c, d] \rightarrow \mathbb{C}$ are *equivalent* if there is a continuously differentiable bijective function $s: [a, b] \rightarrow [c, d]$ such that $s'(t) > 0$ for all $t \in [a, b]$ and $\gamma_1 = \gamma_2 \circ s$. It is straightforward to check that equivalence is indeed an equivalence relation on parametrized paths, and we will call the equivalence classes *oriented curves* in the complex plane. We denote the equivalence class of γ by $[\gamma]$. The condition that $s'(t) > 0$ ensures that the path is traversed in the same direction for each of the parametrizations γ_1 and γ_2 . Moreover, γ_1 is piecewise C^1 if and only if γ_2 is.

Remark 2.1.6. Note that if $\gamma: [a, b] \rightarrow \mathbb{C}$ is piecewise C^1 , then by choosing a reparametrization by a function $\psi: [a, b] \rightarrow [a, b]$ which is strictly increasing and has vanishing derivative at the points where γ fails to be C^1 , we can replace γ by $\tilde{\gamma} = \gamma \circ \psi$ to obtain a C^1 path with the same image. For this reason, some texts insist that C^1 paths have everywhere non-vanishing derivative.

In this course we will not insist on this. Indeed sometimes it is convenient to consider a *constant* path, that is a path $\gamma: [a, b] \rightarrow \mathbb{C}$ such that $\gamma(t) = z_0$ for all $t \in [a, b]$ (and hence $\gamma'(t) = 0$ for all $t \in [a, b]$).



Example 2.1.7. The most basic example of a closed curve is a circle: If $z_0 \in \mathbb{C}$ and $r > 0$ then the path $z(t) = z_0 + re^{2\pi it}$ (for $t \in [0, 1]$) is the simple closed path with *positive orientation* encircling z_0 with radius r . The path $\tilde{z}(t) = z_0 + re^{-2\pi it}$ is the simple closed path encircling z_0 with radius r and *negative orientation*.

Another useful path is a line segment: if $a, b \in \mathbb{C}$ then we denote by $\gamma_{[a,b]}: [0, 1] \rightarrow \mathbb{C}$ the path given by $t \mapsto a + t(b - a) = (1 - t)a + tb$ traverses the line segment from a to b . We denote the corresponding oriented curve by $[a, b]$ (which is consistent with the notation for an interval in the real line). One of the simplest classes of closed paths is triangles: given three points a, b, c , we define the triangle, or triangular path, associated to them, to be the concatenation of the associated line segments, that is $\gamma_{a,b,c} = \gamma_{[a,b]} \star \gamma_{[b,c]} \star \gamma_{[c,a]}$.

2.2 Integration along a path

To define the integral of a complex-valued function along a path, we first need to define the integral of functions $f: [a, b] \rightarrow \mathbb{C}$ on a closed interval $[a, b]$ taking values in \mathbb{C} . Last year in Analysis III the Riemann integral was defined for a function on a closed interval $[a, b]$ taking values in \mathbb{R} , but it is easy to extend this to functions taking values in \mathbb{C} : Indeed we may write $f(t) = u(t) + iv(t)$ where u, v are functions on $[a, b]$ taking real values. Then we say that f is Riemann integrable if both u and v are, and we define:

$$\int_a^b f(t)dt = \int_a^b u(t)dt + i \int_a^b v(t)dt$$

It is easy to check that the integral is then complex linear, that is, if f_1, f_2 are complex-valued Riemann integrable functions on $[a, b]$, and $\alpha, \beta \in \mathbb{C}$, then $\alpha f_1 + \beta f_2$ is Riemann integrable and

$$\int_a^b (\alpha f_1 + \beta f_2)dt = \alpha \int_a^b f_1 dt + \beta \int_a^b f_2 dt.$$

Note that if f is continuous, then its real and imaginary parts are also continuous, and so, in particular, Riemann integrable¹. The class of Riemann integrable (real or complex-valued) functions on a closed interval is however slightly larger than the class of continuous functions, and this will be useful to us at certain points. In particular, we have the following:

¹It is clear this definition extends to give a notion of the integral of a function $f: [a, b] \rightarrow \mathbb{R}^n$ – we say f is integrable if each of its components is, and then define the integral to be the vector given by the integrals of each component function.

Lemma 2.2.1. *Let $[a, b]$ be a closed interval and $S \subset [a, b]$ a finite set. If f is a bounded continuous function (taking real or complex values) on $[a, b] \setminus S$ then it is Riemann integrable on $[a, b]$.*

Proof. The case of complex-valued functions follows from the real case by taking real and imaginary parts. For the case of a function $f: [a, b] \setminus S \rightarrow \mathbb{R}$, let $a = x_0 < x_1 < x_2 < \dots < x_k = b$ be any partition of $[a, b]$ which includes the elements of S . Then on each open interval (x_i, x_{i+1}) the function f is bounded and continuous, and hence integrable. We may therefore set

$$\int_a^b f(t)dt = \int_{x_0}^{x_1} f(t)dt + \int_{x_1}^{x_2} f(t)dt + \dots + \int_{x_{k-1}}^{x_k} f(t)dt$$

The standard additivity properties of the integral then show that $\int_a^b f(t)dt$ is independent of any choices. \square

Remark 2.2.2. Note that normally when one speaks of a function f being integrable on an interval $[a, b]$ one assumes that f is defined on all of $[a, b]$. However, if we change the value of a Riemann integrable function f at a finite set of points, then the resulting function is still Riemann integrable and its integral is the same. Thus if one prefers the function f in the previous lemma to be defined on all of $[a, b]$ one can define f to take any values at all on the finite set S .

Lemma 2.2.3. *Suppose that $f: [a, b] \rightarrow \mathbb{C}$ is a complex-valued function. Then we have*

$$\left| \int_a^b f(t)dt \right| \leq \int_a^b |f(t)|dt.$$

Proof. First note that if $f(t) = u(t) + iv(t)$ then $|f(t)| = \sqrt{u^2 + v^2}$ so that if f is integrable then $|f(t)|$ is also integrable². We may write $\int_a^b f(t)dt = re^{i\theta}$, where $r \in [0, \infty)$ and $\theta \in [0, 2\pi)$. Now taking the components of f in the direction of $e^{i\theta}$ and $e^{i(\theta+\pi/2)} = ie^{i\theta}$, we may write $f(t) = \tilde{u}(t)e^{i\theta} + i\tilde{v}(t)e^{i\theta}$. Then by our choice of θ we have $\int_a^b f(t)dt = e^{i\theta} \int_a^b \tilde{u}(t)dt$, and so

$$\left| \int_a^b f(t)dt \right| = \left| \int_a^b \tilde{u}(t)dt \right| \leq \int_a^b |\tilde{u}(t)|dt \leq \int_a^b |f(t)|dt,$$

where in the first inequality we used the triangle inequality for the Riemann integral of real-valued functions. \square

²The simplest way to see this is to use that fact that if ϕ is continuous and f is Riemann integrable, then $\phi \circ f$ is Riemann integrable.

We are now ready to define the integral of a function $f: \mathbb{C} \rightarrow \mathbb{C}$ along a piecewise- C^1 curve.

Definition 2.2.4. If $\gamma: [a, b] \rightarrow \mathbb{C}$ is a piecewise- C^1 path and $f: \mathbb{C} \rightarrow \mathbb{C}$, then we define the integral of f along γ to be

$$\int_{\gamma} f(z)dz = \int_a^b f(\gamma(t))\gamma'(t)dt.$$

In order for this integral to exist in the sense we have defined, we have seen that it suffices for the functions $f(\gamma(t))$ and $\gamma'(t)$ to be bounded and continuous at all but finitely many t . Our definition of a piecewise C^1 -path ensures that $\gamma'(t)$ is bounded and continuous away from finitely many points (the boundedness follows from the existence of the left and right-hand limits at points of discontinuity of $\gamma'(t)$). For most of our applications, the function f will be continuous on the whole image γ^* of γ , but it will occasionally be useful to weaken this to allow $f(\gamma(t))$ finitely many (bounded) discontinuities.

Lemma 2.2.5. If $\gamma: [a, b] \rightarrow \mathbb{C}$ be a piecewise C^1 path and $\tilde{\gamma}: [c, d] \rightarrow \mathbb{C}$ is an equivalent path, then for any continuous function $f: \mathbb{C} \rightarrow \mathbb{C}$ we have

$$\int_{\gamma} f(z)dz = \int_{\tilde{\gamma}} f(z)dz.$$

In particular, the integral only depends on the oriented curve $[\gamma]$.

Proof. Since $\tilde{\gamma}$ is equivalent to γ there is a continuously differentiable function $s: [c, d] \rightarrow [a, b]$ with $s(c) = a$, $s(d) = b$ and $s'(t) > 0$ for all $t \in [c, d]$. Suppose first that γ is C^1 . Then by the chain rule, we have

$$\begin{aligned} \int_{\tilde{\gamma}} f(z)dz &= \int_c^d f(\gamma(s(t))) (\gamma \circ s)'(t)dt \\ &= \int_c^d f(\gamma(s(t))) \gamma'(s(t)) s'(t)dt \\ &= \int_a^b f(\gamma(s)) \gamma'(s)ds \\ &= \int_{\gamma} f(z)dz. \end{aligned}$$

where in the second last equality we used the change of variables formula. If $a = x_0 < x_1 < \dots < x_n = b$ is a decomposition of $[a, b]$ into subintervals

such that γ is C^1 on $[x_i, x_{i+1}]$ for $1 \leq i \leq n-1$ then since s is a continuous increasing bijection, we have a corresponding decomposition of $[c, d]$ given by the points $s^{-1}(x_0) < \dots < s^{-1}(x_n)$, and we have

$$\begin{aligned} \int_{\tilde{\gamma}} f(z) dz &= \int_c^d f(\gamma(s(t))) \gamma'(s(t)) s'(t) dt \\ &= \sum_{i=0}^{n-1} \int_{s^{-1}(x_i)}^{s^{-1}(x_{i+1})} f(\gamma(s(t))) \gamma'(s(t)) s'(t) dt \\ &= \sum_{i=0}^{n-1} \int_{x_i}^{x_{i+1}} f(\gamma(x)) \gamma'(x) dx \\ &= \int_a^b f(\gamma(x)) \gamma'(x) dx = \int_{\gamma} f(z) dz. \end{aligned}$$

where the third equality follows from the case of C^1 paths established above. \square

Definition 2.2.6. If $\gamma: [a, b] \rightarrow \mathbb{C}$ is a C^1 path then we define the *length* of γ to be

$$\ell(\gamma) = \int_a^b |\gamma'(t)| dt.$$

Using the chain rule as we did to show that the integrals of a function $f: \mathbb{C} \rightarrow \mathbb{C}$ along equivalent paths are equal, one can check that the length of a parametrized path is also constant on equivalence classes of paths, so, in fact, the above defines a length function for oriented curves. The definition extends in an obvious way to give a notion of length for piecewise C^1 -paths. More generally, one can define the integral *with respect to arc-length* of a function $f: U \rightarrow \mathbb{C}$ such that $\gamma^* \subseteq U$ to be

$$\int_{\gamma} f(z) |dz| = \int_a^b f(\gamma(t)) |\gamma'(t)| dt.$$

This integral is invariant with respect to C^1 reparametrizations $s: [c, d] \rightarrow [a, b]$ if we require $s'(t) \neq 0$ for all $t \in [c, d]$ (the condition $s'(t) > 0$ is not necessary because of this integral takes the modulus of $\gamma'(t)$). In particular $\ell(\gamma) = \ell(\gamma^-)$.

Remark 2.2.7 (Non-examinable). It is possible to relax the assumption that γ is (piecewise) C^1 and replace it with the assumption that it has a finite



length. The length can be defined using partitions (like in the definition of the Riemann integral) so we don't even need γ to be differentiable. Such curves are called *rectifiable*. With minimal modifications, everything we do in this course can be done for rectifiable curves.

The integration of functions along piecewise smooth paths has many of the properties that the integral of real-valued functions along an interval possesses. We record some of the most standard of these:

Proposition 2.2.8. *Let $f, g: U \rightarrow \mathbb{C}$ be continuous functions on an open subset $U \subseteq \mathbb{C}$ and $\gamma, \eta: [a, b] \rightarrow \mathbb{C}$ be piecewise- C^1 paths whose images lie in U . Then we have the following:*

1. (Linearity): For $\alpha, \beta \in \mathbb{C}$,

$$\int_{\gamma} (\alpha f(z) + \beta g(z)) dz = \alpha \int_{\gamma} f(z) dz + \beta \int_{\gamma} g(z) dz.$$

2. (Orientation): If γ^- denotes the opposite path to γ then

$$\int_{\gamma} f(z) dz = - \int_{\gamma^-} f(z) dz.$$

3. (Additivity): If $\gamma \star \eta$ is the concatenation of the paths γ, η in U , we have

$$\int_{\gamma \star \eta} f(z) dz = \int_{\gamma} f(z) dz + \int_{\eta} f(z) dz.$$

4. (Estimation Lemma.) We have

$$\left| \int_{\gamma} f(z) dz \right| \leq \sup_{z \in \gamma^*} |f(z)| \ell(\gamma).$$

Proof. Since f, g are continuous, and γ, η are piecewise C^1 , all the integrals in the statement are well-defined: the functions $f(\gamma(t))\gamma'(t)$, $f(\eta(t))\eta'(t)$, $g(\gamma(t))\gamma'(t)$ and $g(\eta(t))\eta'(t)$ are all Riemann integrable. It is easy to see that one can reduce these claims to the case where γ is smooth. The first claim is immediate from the linearity of the Riemann integral, while the second claim follows from the definitions and the fact that $(\gamma^-)'(t) = -\gamma'(a+b-t)$. The third follows immediately for the corresponding additivity property of Riemann integrable functions.

For the fourth part, first note that $\gamma([a, b])$ is compact in \mathbb{C} since it is the image of the compact set $[a, b]$ under a continuous map. It follows that the

function $|f|$ is bounded on this set so that $\sup_{z \in \gamma([a,b])} |f(z)|$ exists. Thus we have

$$\begin{aligned} \left| \int_{\gamma} f(z) dz \right| &= \left| \int_a^b f(\gamma(t)) \gamma'(t) dt \right| \\ &\leq \int_a^b |f(\gamma(t))| |\gamma'(t)| dt \\ &\leq \sup_{z \in \gamma^*} |f(z)| \int_a^b |\gamma'(t)| dt \\ &= \sup_{z \in \gamma^*} |f(z)| \ell(\gamma). \end{aligned}$$

where for the first inequality we use the triangle inequality for complex-valued functions as in Lemma 2.2.3 and the positivity of the Riemann integral for the second inequality. \square

Remark 2.2.9. We give part (4) of the above proposition a name (the “estimation lemma”) because it will be very useful later in the course. We will give one important application of it now:

Proposition 2.2.10. *Let $f_n: U \rightarrow \mathbb{C}$ be a sequence of continuous functions on an open subset U of the complex plane. Suppose that $\gamma: [a,b] \rightarrow \mathbb{C}$ is a path whose image is contained in U . If (f_n) converges uniformly to a function f on the image of γ then*

$$\int_{\gamma} f_n(z) dz \rightarrow \int_{\gamma} f(z) dz.$$

Proof. We have

$$\begin{aligned} \left| \int_{\gamma} f(z) dz - \int_{\gamma} f_n(z) dz \right| &= \left| \int_{\gamma} (f(z) - f_n(z)) dz \right| \\ &\leq \sup_{z \in \gamma^*} \{|f(z) - f_n(z)|\} \ell(\gamma), \end{aligned}$$

by the estimation lemma. Since we are assuming that f_n tends to f uniformly on γ^* we have $\sup\{|f(z) - f_n(z)| : z \in \gamma^*\} \rightarrow 0$ as $n \rightarrow \infty$ which implies the result. \square

Definition 2.2.11. Let $U \subseteq \mathbb{C}$ be an open set and let $f: U \rightarrow \mathbb{C}$ be a continuous function. If there exists a differentiable function $F: U \rightarrow \mathbb{C}$ with $F'(z) = f(z)$ then we say F is a *primitive* for f on U .

We will need a version of the chain rule for the composition of a complex with a real function:

Lemma 2.2.12. *Let U be an open subset of \mathbb{C} and let $f: U \rightarrow \mathbb{C}$ be a holomorphic function. If $\gamma: [a, b] \rightarrow U$ is a (piecewise) C^1 -path, then $f(\gamma(t))$ is differentiable at any t where γ is differentiable and*

$$\frac{d}{dt}(f(\gamma(t))) = f'(\gamma(t)) \cdot \gamma'(t)$$

Proof. Assume that γ is differentiable at $t_0 \in [a, b]$ and let $z_0 = \gamma(t_0) \in U$. By definition of f' , there is a function $\epsilon(z)$ such that

$$f(z) = f(z_0) + f'(z_0)(z - z_0) + \epsilon(z)(z - z_0)$$

where $\epsilon(z) \rightarrow 0 = \epsilon(z_0)$ as $z \rightarrow z_0$. But then

$$\frac{f(\gamma(t)) - f(\gamma(t_0))}{t - t_0} = f'(z_0) \cdot \frac{\gamma(t) - \gamma(t_0)}{t - t_0} + \epsilon(\gamma(t)) \cdot \frac{\gamma(t) - \gamma(t_0)}{t - t_0}.$$

But now consider the two terms on the right-hand side of this expression: the first term, as $t \rightarrow t_0$ tends to $f'(z_0)(\gamma'(t_0))$. On the other hand, for the second term, since $\frac{\gamma(t) - \gamma(t_0)}{t - t_0}$ tends to $\gamma'(t_0)$ as t tends to t_0 , we see that $\gamma(t) - \gamma(t_0)/(t - t_0)$ is bounded as $t \rightarrow t_0$, while since $\gamma(t)$ is continuous at t_0 since it is differentiable there, $\epsilon(\gamma(t)) \rightarrow \epsilon(\gamma(t_0)) = \epsilon(z_0) = 0$. It follows that the second term tends to zero, so that the left-hand side tends to $f'(z_0)(\gamma'(t_0))$ as $t \rightarrow t_0$, as required. \square

The fundamental theorem of calculus has the following important consequence³:

Theorem 2.2.13. *(Fundamental theorem of Calculus): Let $U \subseteq \mathbb{C}$ be open and let $f: U \rightarrow \mathbb{C}$ be a continuous function. If $F: U \rightarrow \mathbb{C}$ is a primitive for f and $\gamma: [a, b] \rightarrow U$ is a piecewise C^1 path in U then we have*

$$\int_{\gamma} f(z) dz = F(\gamma(b)) - F(\gamma(a)).$$

In particular, the integral of such a function f around any closed path is zero.

³You should compare this to the existence of a potential in vector calculus.

Proof. First suppose that γ is C^1 . Then we have

$$\begin{aligned}\int_{\gamma} f(z)dz &= \int_{\gamma} F'(z)dz = \int_a^b F'(\gamma(t))\gamma'(t)dt \\ &= \int_a^b \frac{d}{dt}(F \circ \gamma)(t)dt \\ &= F(\gamma(b)) - F(\gamma(a)),\end{aligned}$$

where in the second line we used the chain rule (lemma 2.2.12) and in the last line we used the Fundamental Theorem of Calculus from Prelims analysis on the real and imaginary parts of $F \circ \gamma$.

If γ is only⁴ piecewise C^1 , then take a partition $a = a_0 < a_1 < \dots < a_k = b$ such that γ is C^1 on $[a_i, a_{i+1}]$ for each $i \in \{0, 1, \dots, k-1\}$. Then we obtain a telescoping sum:

$$\begin{aligned}\int_{\gamma} f(z) &= \int_a^b f(\gamma(t))\gamma'(t)dt \\ &= \sum_{i=0}^{k-1} \int_{a_i}^{a_{i+1}} f(\gamma(t))\gamma'(t)dt \\ &= \sum_{i=0}^{k-1} (F(\gamma(a_{i+1})) - F(\gamma(a_i))) \\ &= F(\gamma(b)) - F(\gamma(a)),\end{aligned}$$

Finally, since γ is closed precisely when $\gamma(a) = \gamma(b)$ it follows immediately that the integral of f along a closed path is zero. \square

Remark 2.2.14. If $f(z)$ has finitely many points of discontinuity $S \subset U$ but is bounded near them, and $\gamma(t) \in S$ for only finitely many t , then provided F is continuous and $F' = f$ on $U \setminus S$, the same proof shows that the fundamental theorem still holds – one just needs to take a partition of $[a, b]$ to take account of those singularities along with the singularities of $\gamma'(t)$.

Theorem 2.2.13 already has an important consequence:

Corollary 2.2.15. *Let U be a domain and let $f: U \rightarrow \mathbb{C}$ be a function with $f'(z) = 0$ for all $z \in U$. Then f is constant.*

⁴The reason we must be careful about this case is that the Fundamental Theorem of Calculus only holds when the integrand is continuous.

Proof. Pick $z_0 \in U$. It has been shown in the Metric Spaces course that an open connected set of a normed space (in particular \mathbb{C}) is path-connected and in fact even polygonally connected, i.e. any two points of the set can be connected by the concatenation of finitely many line segments. It follows that any point w of U can be joined to z_0 by a piecewise C^1 -path $\gamma: [0, 1] \rightarrow U$ so that $\gamma(0) = z_0$ and $\gamma(1) = w$. Then by Theorem 2.2.13 we see that

$$f(w) - f(z_0) = \int_{\gamma} f'(z) dz = 0,$$

so that f is constant as required. \square

The following theorem is a kind of converse to the fundamental theorem:

Theorem 2.2.16. *If U is a domain (i.e. it is open and path connected) and $f: U \rightarrow \mathbb{C}$ is a continuous function such that for any closed path in U we have $\int_{\gamma} f(z) dz = 0$, then f has a primitive.*

Proof. Fix z_0 in U , and for any $z \in U$ set

$$F(z) = \int_{\gamma} f(z) dz$$

where $\gamma: [a, b] \rightarrow U$ with $\gamma(a) = z_0$ and $\gamma(b) = z$ (note that we abuse notations and use z as both the end-point of the curve and the dummy variable in the integration).

We claim that $F(z)$ is independent of the choice of γ . Indeed if γ_1, γ_2 are two such paths, let $\gamma = \gamma_1 \star \gamma_2^-$ be the path obtained by concatenating γ_1 and the opposite γ_2^- of γ_2 (that is, γ traverses the path γ_1 and then goes backward along γ_2). Then γ is a closed path and so, using Proposition 2.2.8 we have

$$0 = \int_{\gamma} f(z) dz = \int_{\gamma_1} f(z) dz + \int_{\gamma_2^-} f(z) dz,$$

hence since $\int_{\gamma_2^-} f(z) dz = - \int_{\gamma_2} f(z) dz$ we see that $\int_{\gamma_1} f(z) dz = \int_{\gamma_2} f(z) dz$.

Next, we claim that F is differentiable with $F'(z) = f(z)$. To see this, fix $w \in U$ and $\epsilon > 0$ such that $B(w, \epsilon) \subseteq U$ and choose a path $\gamma: [a, b] \rightarrow U$ from z_0 to w . If $z \in B(w, \epsilon) \subseteq U$, then the concatenation of γ with the straight-line path $s: [0, 1] \rightarrow U$ given by $s(t) = w + t(z - w)$ from w to z is

a path γ_1 from z_0 to z . It follows that

$$\begin{aligned} F(z) - F(w) &= \int_{\gamma_1} f(z)dz - \int_{\gamma} f(z)dz \\ &= \left(\int_{\gamma} f(z)dz + \int_s f(z)dz \right) - \int_{\gamma} f(z)dz \\ &= \int_s f(z)dz. \end{aligned}$$

But then we have for $z \neq w$

$$\begin{aligned} \left| \frac{F(z) - F(w)}{z - w} - f(w) \right| &= \left| \frac{1}{z - w} \left(\int_0^1 f(w + t(z - w))(z - w)dt \right) - f(w) \right| \\ &= \left| \int_0^1 (f(w + t(z - w)) - f(w))dt \right| \\ &\leq \sup_{t \in [0,1]} |f(w + t(z - w)) - f(w)| \rightarrow 0 \text{ as } z \rightarrow w \end{aligned}$$

as f is continuous at w . Thus F is differentiable at w with derivative $F'(w) = f(w)$ as claimed. \square

Remark 2.2.17. Note that any two primitives for a function f differ by a constant: This follows immediately from Corollary 2.2.15, since if F_1 and F_2 are two primitives, their difference $(F_1 - F_2)$ has zero derivative.

The combination of all of these results means that a continuous function has a primitive if and only if integrals around any closed path are equal to zero. Let us compare this with the real case. Any continuous function on a bounded interval is integrable and hence has a primitive. It is also easy to see that the integral along any closed path is zero because in \mathbb{R} closed paths go back and forth and so cancel out. This is not the case in \mathbb{C} as shown by an example below.



Example 2.2.18. Let $U = \mathbb{C} \setminus \{0\}$ and $f(z) = 1/z$ which is a continuous function in U . Let $\gamma(t) = e^{it} : [0, 2\pi] \rightarrow U$ be the unit circle. Then

$$\int_{\gamma} f(z)dz = \int_0^{2\pi} \frac{1}{e^{it}} ie^{it} dt = 2\pi i \neq 0.$$

This shows that $1/z$ does not have a primitive in U .



It is important to keep in mind that whether a function has a primitive depends not only on the function itself but also on the domain. In particular, $1/z$ has a primitive in $U = \mathbb{C} \setminus (-\infty, 0]$ since $\text{Log}'(z) = 1/z$ where Log is the principal value of the logarithm.

The argument above never used that Log is the principal value, any branch will work. If L is a branch of the logarithm in some domain U , then its derivative there must be $1/z$, hence $1/z$ has a primitive in U .

2.3 Cauchy's theorem

In this section, we prove one of the most fundamental results about holomorphic functions. Essentially the rest of the course will be based on this result. It has many different forms, here we will formulate some of them, but full proofs are beyond the scope of this course, so we will only prove a simpler version and give a brief indication of how the general result can be proved.

Theorem 2.3.1 (Cauchy or Cauchy-Goursat Theorem). *Let $U \subset \mathbb{C}$ be a domain and γ be a closed curve such that it and all bounded components of $\mathbb{C} \setminus \gamma^*$ are inside U . Let f be a function holomorphic in U . Then*

$$\int_{\gamma} f(z) dz = 0.$$

Remark 2.3.2. Note that in this theorem we do not assume that γ is simple.

We will start by proving this result in a very simple case when $\gamma = \gamma_{a,b,c}$ is the boundary of a triangle.

Proof of Theorem 2.3.1 for triangles. Let $T = T_0$ be a triangle with vertices A , B and C . Let $\gamma = \gamma_{A,B,C}$ be its boundary, Slightly abusing notations⁵ we will write $\gamma = \partial T$. We assume that it is positively (i.e. counter clockwise) oriented. This is not important since reversing orientation changes the sign but we will show that the integral is equal to zero, so the sign is irrelevant.

We split T into four similar triangles S_i , $i = 1, \dots, 4$. New vertices are mid-points of edges. See Figure 2.3 for an illustration.

⁵The main issue is that when we write $\gamma_{A,B,C}$ we use the concatenation of sides in the counter-clockwise order starting from $[A, B]$, in particular, A is the beginning and the end of the curve. When we write ∂T , then we do not specify the orientation and the starting point. On the other hand, the standard orientation in complex analysis is counter-clockwise and it is easy to see that the integral does not depend on the starting point.

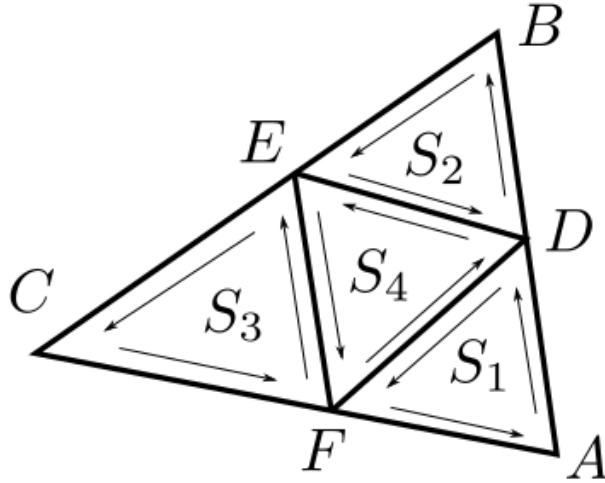

Figure 2.1: Splitting the triangle into four similar triangles.

We claim that

$$\int_{\partial T} f(z) dz = \sum_{i=1}^4 \int_{\partial S_i} f(z) dz.$$

The reason is very simple. The integral along the boundary of a triangle is equal to the sum of integrals along its edges. Note that ‘new’ edges appear twice with different orientations. For example, the edge $[D, F]$ appears in the boundary of S_1 and $[F, D]$ in the boundary of S_4 . Since they have the opposite orientation, integrals along them will cancel out. The remaining six integrals will add up to the integral along the boundary of the original triangle.

Denote $\int_{\partial T} f = I$ and assume that $I \neq 0$. In this case, there is one of S_i such that

$$\left| \int_{\partial S_i} f(z) dz \right| \geq \frac{1}{4} |I|.$$

We denote this smaller triangle by T_1 and repeat the same process: split it into four triangles and choose one with a large integral. This way we obtain a sequence of triangles T_n such that $T_n \subset T_{n-1}$,

$$\left| \int_{\partial T_n} f(z) dz \right| \geq \frac{1}{4^n} |I| \tag{2.3.1}$$

and

$$\ell(\partial T_n) = 2^{-n} \ell(\partial T). \quad (2.3.2)$$

It is not hard to prove directly that there is $z_0 = \cap T_n$. Alternatively, we have a nested family of compacts in a metric space and their diameters go to zero. By a result from the Metric Spaces course, their intersection is a single point.

Function f is differentiable at z_0 hence

$$f(z) = f(z_0) + f'(z_0)(z - z_0) + \epsilon(z)(z - z_0)$$

where $\epsilon(z) \rightarrow 0$ as $z \rightarrow z_0$. For any $\epsilon > 0$ there is $\delta > 0$ such that $|\epsilon(z)| < \epsilon$ for all $z \in B(z_0, \delta)$.

Next, we choose n large enough so that $T_n \subset B(z_0, \delta)$. Then

$$\int_{\partial T_n} f(z) dz = \int_{\partial T_n} (f(z_0) + f'(z_0)(z - z_0)) dz + \int_{\partial T_n} \epsilon(z)(z - z_0) dz.$$

The first integral vanishes since $f(z_0) + f'(z_0)(z - z_0)$ is a linear function which clearly has a primitive and so its integral along any closed contour is zero. By the estimation lemma

$$\left| \int_{\partial T_n} f(z) dz \right| \leq \epsilon \ell^2(\partial T_n).$$

Here we used that $|z - z_0| \leq \ell(\partial T_n)$ since the distance between any two points in a triangle is bounded by its perimeter.

Combining this with (2.3.1) and (2.3.2) we have

$$\frac{1}{4^n} |I| \leq \left| \int_{\partial T_n} f(z) dz \right| \leq \epsilon \ell^2(\partial T) \frac{1}{4^n}$$

which leads to a contradiction if we choose $\epsilon < |I|/\ell^2(\partial T)$. \square

Next we show that for a large class of ‘nice’ domains our previous argument about triangular curves implies that the theorem is true for all curves. We start with a couple of definitions.

Definition 2.3.3. Let X be a subset in \mathbb{C} . We say that X is *convex* if for each $z, w \in X$ the line segment between z and w is contained in X . We say that X is *star-like* if there is a point $z_0 \in X$ such that for every $w \in X$ the line segment $[z_0, w]$ joining z_0 and w lies in X . We will say that X is star-like with respect to z_0 in this case. Thus a convex subset is starlike with respect to every point it contains.

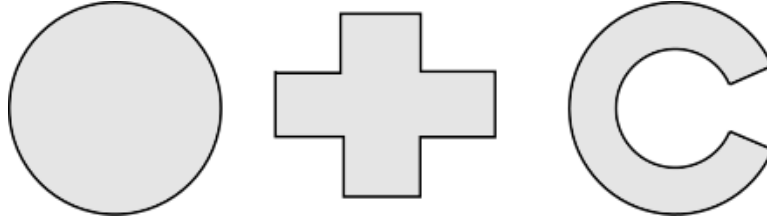

Figure 2.2: The disc is both convex and star-like, the cross is not convex but star-like and the shape on the right is neither.

Example 2.3.4. A disk (open or closed) is convex, as is a solid triangle or rectangle. On the other hand a cross, such as $[-2, 2] \times [-1, 1] \cup [-1, 1] \times [-2, 2]$ is star-like with respect to the origin, but is not convex. See

Proof of Theorem 2.3.1 for star-like domains. The proof proceeds similarly to the proof of Theorem 2.2.16: by Theorem 2.2.13 it suffices to show that f has a primitive in U . To show this, let $z_0 \in U$ be a point for which the line segment from z_0 to every $z \in U$ lies in U . Let $\gamma_z = z_0 + t(z - z_0)$ be a parametrization of this curve, and define

$$F(z) = \int_{\gamma_z} f(\zeta) d\zeta.$$

We claim that F is a primitive for f on U . Indeed pick $\epsilon > 0$ such that $B(z, \epsilon) \subseteq U$. Then if $w \in B(z, \epsilon)$ note that the triangle T with vertices z_0, z, w lies entirely in U by the assumption that U is star-like with respect to z_0 . We have already proved that in this case that $\int_{\partial T} f(\zeta) d\zeta = 0$, and hence if $\eta(t) = w + t(z - w)$ is the straight-line path going from w to z (so that ∂T is the concatenation of γ_w, η and γ_z^- , see Figure 2.3) we have

$$\begin{aligned} \left| \frac{F(z) - F(w)}{z - w} - f(z) \right| &= \left| \int_{\eta} \frac{f(\zeta)}{z - w} d\zeta - f(z) \right| \\ &= \left| \int_0^1 f(w + t(z - w)) dt - f(z) \right| \\ &= \left| \int_0^1 (f(w + t(z - w)) - f(z)) dt \right| \\ &\leq \sup_{t \in [0, 1]} |f(w + t(z - w)) - f(z)|, \end{aligned}$$

which, since f is continuous at w , tends to zero as $w \rightarrow z$ so that $F'(z) =$

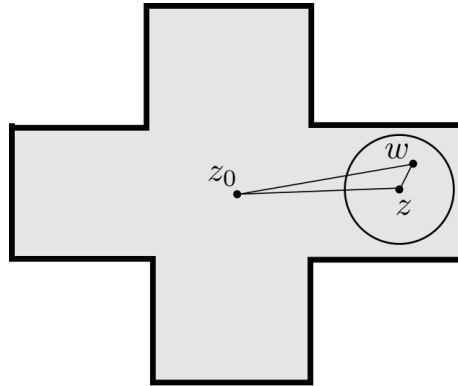

Figure 2.3: In a star-like domain if z and w are close enough then the triangle z, z_0, w is completely inside the domain.

$f(z)$ as required. □

Finally, we outline the strategy of how to prove Theorem 2.3.1 in its stated form. This part is non-examinable.



Outline of the proof of Theorem 2.3.1. Non-examinable. First, let us assume that γ is a polygonal curve i.e. a concatenation of a finite number of intervals. If γ is not a simple curve then the corresponding polygon can be decomposed into a finite number of simple polygons S_i . It is easy to see that $\int_{\gamma} = \sum \int_{\partial S_i}$. When γ is a simple curve, then the corresponding polygon can be triangulated into triangles S_i . See Figure As before, the integrals along new sides cancel out and again $\int_{\gamma} = \sum \int_{\partial S_i}$. Since we already know that integrals along triangles are equal to zero, this immediately proves the statement for polygonal curves.

Note, that the argument above is almost complete. The only non-trivial part is the statement that any polygon can be triangulated. This sounds obvious, and in fact it is not very difficult proof but it is a bit tricky to write down rigorously with all details.



Next, let $\gamma : [a, b] \rightarrow \mathbb{C}$ be a general curve. It is not very difficult to show that similarly to the real case, a complex integral can be approximated by a Riemann sum. Namely, if t_i form a sufficiently fine partition and $z_i = \gamma(t_i)$ then

$$\sum f(z_i)(z_{i+1} - z_i) \rightarrow \int_{\gamma} f(z)dz$$

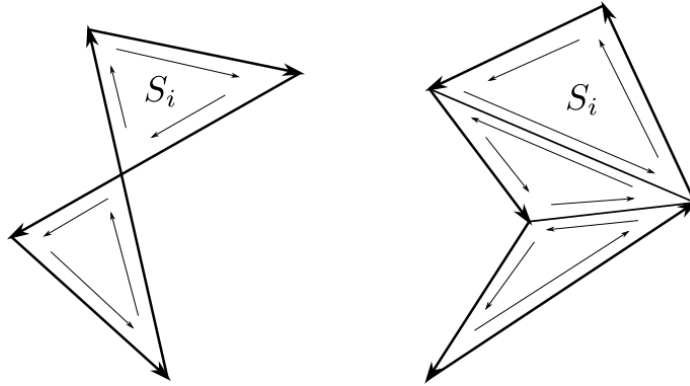

Figure 2.4: Left: a non-simple polygon can be decomposed into simple polygons. Right: a simple polygon can be decomposed into triangles.

as the mesh goes to 0. Clearly, an integral along the part of γ from t_i to t_{i+1} is close to $f(z_i)(z_{i+1} - z_i)$ (since the curve is almost an interval and the function is almost a constant. This part is relatively easy to justify. It is a bit harder to justify that the sum of errors is still small and

$$\sum \int_{\gamma_i} f(z) dz \rightarrow \int_{\gamma} f(z) dz,$$

where γ_i is an interval $[z_i, z_{i+1}]$. The sum above is equal to the integral of f along the polygonal curve with vertices z_i . As we have shown before, such an integral is equal to 0, so its limit is also 0. \square

2.4 Deformation theorem and homotopy

In this section we state the most general version of the Cauchy's theorem. Roughly speaking it states that if we continuously deform a curve then the integral does not change. This is true even if the integral is not zero. This should not be surprising given our previous discussion. If we move a curve a little bit, then the difference between two curves is a small contour and the function is analytic inside of it, so by the previous version of the Cauchy theorem the difference in integrals is equal to the integral along this contour which is zero. Making this argument rigorous is not extremely difficult but goes beyond the scope of this course. So we will rigorously define and set up everything but will not prove most of the statements in this section.

Definition 2.4.1. Suppose that U is an open set in \mathbb{C} and $a, b \in U$ and that $\gamma_0: [0, 1] \rightarrow U$ and $\gamma_1: [0, 1] \rightarrow U$ are two paths in U such that $\gamma_0(0) =$

$\gamma_1(0) = a$ and $\gamma_0(1) = \gamma_1(1) = b$. We say that γ_0 and γ_1 are *homotopic* in U if there is a continuous function $h: [0, 1] \times [0, 1] \rightarrow U$ such that

$$\begin{aligned} h(0, s) &= a, & h(1, s) &= b \\ h(t, 0) &= \gamma_0(t), & h(t, 1) &= \gamma_1(t). \end{aligned}$$

One should think that h defines a family of curves $\gamma_s(t) = h(t, s)$ that have the same end-points and as s changes from 0 to 1 the curves continuously deform from γ_0 to γ_1 .

For closed curves, the definition is a bit different. We do not require that end-points stay the same but we require that all γ_s are closed curves.

We say that a closed curve γ is *null homotopic in U* if it is homotopic to a constant path.

One can show that the relation “ γ is homotopic to η ” is an equivalence relation, so that any path γ between a and b belongs to a unique equivalence class, known as its homotopy class.

Definition 2.4.2. Suppose that U is a domain in \mathbb{C} . We say that U is *simply connected* if for every $a, b \in U$, any two paths from a to b are homotopic in U . Equivalently, any closed curve is null homotopic.

Remark 2.4.3. The fact that the two definitions are equivalent is non-trivial but it is a topological fact that is beyond the scope of this course.

Example 2.4.4. Any convex or starlike domain is simply connected. The argument is simple. If $\gamma(t)$ is a closed curve and U is star-like with respect to z_0 , then the function

$$h(t, s) = sz_0 + (1 - s)\gamma(t)$$

is a homotopy between γ and a constant path $\gamma_1(t) = z_0$.

Generally, showing that a curve is not null-homotopic or that a domain is not simply connected is harder. Informally, it means that the domain has holes. This can be formalized in the following way: If a domain U does not contain a neighbourhood of infinity (i.e. all points with $|z| > r$ for some r) then it is simply connected if and only if its complement is connected. The entire plane \mathbb{C} is the only simply connected domain containing a neighbourhood of infinity. The proof of this is beyond the scope of this course but it heavily relies on the fact that U is a domain in \mathbb{C} . Without it classifying simply connected sets is much harder.

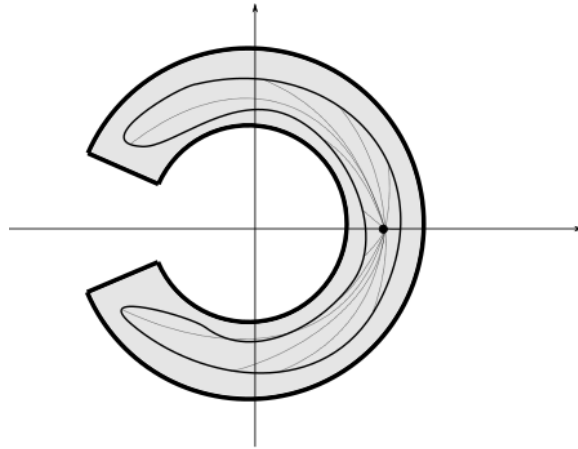

Figure 2.5: A contour inside a horseshoe domain can be contracted to a point along the dotted lines.

Example 2.4.5. An annulus

$$A(z_0, r, R) = \{z \in \mathbb{C} : 0 \leq r < |z - z_0| < R \leq \infty\}$$

is not simply connected. Note that in this definition we allow $r = 0$ and $R = \infty$. We will see that this is indeed the case later in the course.

Example 2.4.6. Let us consider a horseshoe domain and a contour inside it as in Figure 2.4.6. If $\gamma(t) = r(t) \exp(i\theta(t))$ where $\theta(t) \in (-\pi, \pi)$. Let $r_0 > 0$ be a point inside the domain. It is not hard to check that the function

$$h(t, s) = (sr_0 + (1 - s)r(t)) \exp((1 - s)\theta(t))$$

is a homotopy between $\gamma_0 = \gamma$ and $\gamma_1(t) = r_0$. Essentially, we independently contract the modulus to r_0 and the argument to 0. This shows that the domain is simply connected.

We are now ready to state our extension of Cauchy's theorem. The proof is given in the Appendices. The proof is non-examinable.

Theorem 2.4.7 (Homotopy Cauchy's Theorem or Deformation Theorem). *Let U be a domain in \mathbb{C} . Suppose that γ_1 and γ_2 are two paths in U that are homotopic in U .⁶ Let $f : U \rightarrow \mathbb{C}$ be a holomorphic function. Then*

$$\int_{\gamma_1} f(z) dz = \int_{\gamma_2} f(z) dz.$$

⁶So they either have the same endpoint or both are closed

Remark 2.4.8. Notice that this theorem is really more general than the previous versions of Cauchy's theorem we have seen – in the case where a holomorphic function $f: U \rightarrow \mathbb{C}$ has a primitive the conclusion of the previous theorem is, of course, obvious from the Fundamental Theorem of Calculus⁷, and our previous formulations of Cauchy's theorem were proved by producing a primitive for f on U . One significance of the homotopy form of Cauchy's theorem is that it applies to domains U even when there is no primitive for f on U .

Theorem 2.4.9 (Cauchy's theorem for simply connected domains). *Suppose that U is a simply connected domain, let $a, b \in U$, and let $f: U \rightarrow \mathbb{C}$ be a holomorphic function on U . Then if γ_1, γ_2 are paths from a to b we have*

$$\int_{\gamma_1} f(z)dz = \int_{\gamma_2} f(z)dz.$$

In particular, if γ is a closed oriented curve we have $\int_{\gamma} f(z)dz = 0$, and hence any holomorphic function on U has a primitive.

Proof. Since U is simply connected, any two paths from a to b are homotopic, so we can apply Theorem 2.4.7. For the last part, in a simply connected domain any closed path $\gamma: [0, 1] \rightarrow U$, with $\gamma(0) = \gamma(1) = a$ say, is homotopic to some constant path $c(t) = z_0$, and hence $\int_{\gamma} f(z)dz = \int_c f(z)dz = 0$. The final assertion then follows from the Theorem 2.2.16. \square

Remark 2.4.10. Theorem 2.4.9 tells us that in a simply connected domain any holomorphic function has a primitive. In fact, the converse is also true. If any holomorphic function has a primitive then the domain is simply connected.

Example 2.4.11. If $U \subseteq \mathbb{C} \setminus \{0\}$ is simply connected, the previous theorem shows that there is a holomorphic branch of $[\log(z)]$ defined on all of U (since any primitive for $f(z) = 1/z$ will be such a branch).

Example 2.4.12. Let us consider an annulus U and a curve γ which is homotopic to a counter-clockwise oriented circle γ_r . Let $f(z) = 1/z$ (see Figure 2.4.12 for an example). As we have discussed before, f has no primitive in U and $\int_{\gamma_r} f(z)dz = 2\pi i$. By Theorem 2.4.7 $\int_{\gamma} f(z)dz = 2\pi i$ as well.

⁷Indeed the hypothesis that the paths γ_1 and γ_2 are homotopic is irrelevant when f has a primitive on U . If there is a primitive F then for *any* curve connecting a and b the integral is equal to $F(b) - F(a)$ and the integral along any contour is equal to 0.

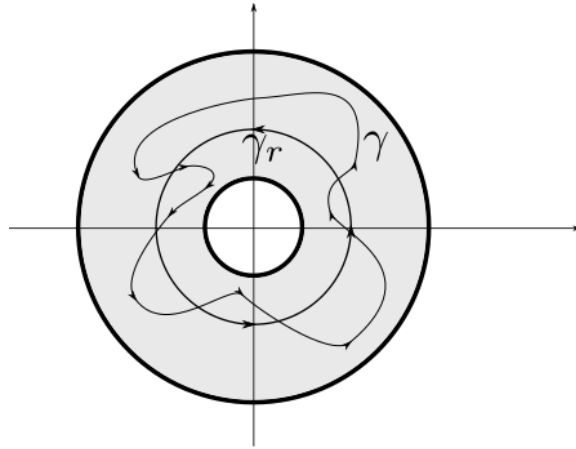

Figure 2.6: A contour is homotopic to a counter-clockwise oriented circle.

2.5 Winding numbers

In the present section we investigate the change in argument as we move along a path. It will turn out to be a basic ingredient in computing integrals around closed paths.

In more detail, suppose that $\gamma: [0, 1] \rightarrow \mathbb{C}$ is a closed path which does not pass through 0. We would like to give a rigorous definition of the number of times γ “goes around the origin”. Roughly speaking, this will be the change in argument $\arg(\gamma(t))$, and therein lies the difficulty, since $\arg(z)$ cannot be defined continuously on all of $\mathbb{C} \setminus \{0\}$. The next Proposition shows that we *can* however always define the argument as a continuous function of the parameter $t \in [0, 1]$:

Proposition 2.5.1. *Let $\gamma: [0, 1] \rightarrow \mathbb{C} \setminus \{0\}$ be a path. Then there is continuous function $a: [0, 1] \rightarrow \mathbb{R}$ such that*

$$\gamma(t) = |\gamma(t)|e^{2\pi ia(t)}.$$

Moreover, if a and b are two such functions, then there exists $n \in \mathbb{Z}$ such that $a(t) = b(t) + n$ for all $t \in [0, 1]$. In particular, the $a(t_0)$ at any t_0 uniquely determines $a(t)$ for all t .

Proof. By replacing $\gamma(t)$ with $\gamma(t)/|\gamma(t)|$ we may assume that $|\gamma(t)| = 1$ for all t . Since γ is continuous on a compact set, it is uniformly continuous, so that there is a $\delta > 0$ such that $|\gamma(s) - \gamma(t)| < \sqrt{3}$ for any s, t with $|s - t| < \delta$. Choose an integer $n > 0$ such that $n > 1/\delta$ so that on each subinterval

$[j/n, (j+1)/n]$ we have $|\gamma(s) - \gamma(t)| < \sqrt{3}/2$. Now on any half-plane in \mathbb{C} we may certainly define a continuous argument function, and if $|z_1| = |z_2| = 1$ and $|z_1 - z_2| < \sqrt{3}$, then the angle between z_1 and z_2 is at most $2\pi/3$. It follows there exists a continuous functions $a_i: [j/n, (j+1)/n] \rightarrow \mathbb{R}$ such that $\gamma(t) = e^{2\pi i a_j(t)}$ for $t \in [j/n, (j+1)/n]$ (since $\gamma([j/n, (j+1)/n])$ must lie in an arc of length at most $2\pi/3$). Now since $e^{2\pi i a_j(j/n)} = e^{2\pi i a_{j-1}(j/n)}$ and $a_{j-1}(j/n)$ and $a_j(j/n)$ differ by an integer. Thus we can successively adjust the a_j for $j > 1$ by an integer (as if $\gamma(t) = e^{2\pi i a_j(t)}$ then $\gamma(t) = e^{2\pi i (a(t)+n)}$ for any $n \in \mathbb{Z}$) to obtain a continuous function $a: [0, 1] \rightarrow \mathbb{C}$ such that $\gamma(t) = e^{2\pi i a(t)}$ as required. Finally, the uniqueness statement follows because $e^{2\pi i (a(t)-b(t))} = 1$, hence $a(t) - b(t) \in \mathbb{Z}$, and since $[0, 1]$ is connected it follows $a(t) - b(t)$ is constant as required. \square

Definition 2.5.2. If $\gamma: [0, 1] \rightarrow \mathbb{C} \setminus \{0\}$ is a closed path and $\gamma(t) = |\gamma(t)|e^{2\pi i a(t)}$ as in the previous lemma, then since $\gamma(0) = \gamma(1)$ we must have $a(1) - a(0) \in \mathbb{Z}$. This integer is called the *winding number* $I(\gamma, 0)$ of γ around 0. It is uniquely determined by the path γ because the function a is unique up to an integer. By translation, if γ is any closed path and z_0 is not in the image of γ , we may define the winding number $I(\gamma, z_0)$ of γ about z_0 in the same fashion. Explicitly, if γ is a closed path with $z_0 \notin \gamma^*$ then let $t: \mathbb{C} \rightarrow \mathbb{C}$ be given by $t(z) = z - z_0$ and define $I(\gamma, z_0) = I(t \circ \gamma, 0)$. This quantity is also called the *index* of z_0 with respect to γ .

Remark 2.5.3. Note that if $\gamma: [0, 1] \rightarrow U$ where $0 \notin U$ and there exists a holomorphic branch $L: U \rightarrow \mathbb{C}$ of $[\log(z)]$ on U , then $I(\gamma, 0) = 0$. Indeed in this case we may define $a(t) = \text{Im}(L(\gamma(t)))$, and since $\gamma(0) = \gamma(1)$ it follows $a(1) - a(0) = 0$ as claimed. Note also that the definition of the winding number only requires the closed path γ to be continuous, not piecewise C^1 . Of course, as usual, we will mostly only be interested in piecewise C^1 paths, as these are the ones along which we can integrate functions.

We now see that the winding number has a natural interpretation in terms of path integrals: Note that if γ is piecewise C^1 then the function $a(t)$ is also piecewise C^1 , since any branch of the logarithm function is in fact differentiable where it is defined, and $a(t)$ is locally given as $\text{Im}(\log(\gamma(t)))$ for a suitable branch.

Lemma 2.5.4. *Let γ be a piecewise C^1 closed path and $z_0 \in \mathbb{C}$ a point not in the image of γ . Then the winding number $I(\gamma, z_0)$ of γ around z_0 is given by*

$$I(\gamma, z_0) = \frac{1}{2\pi i} \int_{\gamma} \frac{dz}{z - z_0}.$$

Proof. If $\gamma: [0, 1] \rightarrow \mathbb{C}$ we may write $\gamma(t) = z_0 + r(t)e^{2\pi ia(t)}$ (where $r(t) = |\gamma(t) - z_0| > 0$ is continuous and the existence of $a(t)$ is guaranteed by Proposition 2.5.1). Then we have

$$\begin{aligned} \int_{\gamma} \frac{dz}{z - z_0} &= \int_0^1 \frac{1}{r(t)e^{2\pi ia(t)}} (r'(t) + 2\pi i r(t)a'(t)) e^{2\pi ia(t)} dt \\ &= \int_0^1 r'(t)/r(t) + 2\pi i a'(t) dt = [\log(r(t)) + 2\pi i a(t)]_0^1 \\ &= 2\pi i (a(1) - a(0)), \end{aligned}$$

since $r(1) = r(0) = |\gamma(0) - z_0|$. \square

Let $\Gamma: [0, 1] \rightarrow \mathbb{C}$ be any simple curve such that $\Gamma(0) = 0$ and $\Gamma(t) \rightarrow \infty$ as $t \rightarrow 1$. Let $U = \mathbb{C} \setminus \Gamma^*$ be the plane without the curve. It can be shown that the winding number of any closed curve in U around 0 is 0. A bit later we will show that the winding number around z is a function which is constant on each component of $\mathbb{C} \setminus \gamma^*$. It is also easy to see that if $|z|$ is very large, then there is a line separating z and γ^* and so $I(\gamma, z) = 0$. This means that the winding number in the unbounded component of $\mathbb{C} \setminus \gamma^*$ is equal to 0. We will present a different argument a bit later in Remark 2.5.8. Since Γ does not intersect γ and connects 0 and infinity, 0 lies in the unbounded component of $\mathbb{C} \setminus \gamma^*$.

All of this proves that $\int_{\gamma} 1/z = 0$ for any closed curve in such domain U and so we can define a branch of $[\log]$ in such a domain. Note that all branches that we have discussed before are of this type. For example, for the principal value we use $\Gamma^* = (-\infty, 0]$.

In fact, one can define logarithm this way. Given such a domain U Theorem 2.2.16 implies that there is a primitive of $1/z$. We can define this primitive to be a branch of the logarithm.

The next Proposition will be useful not only for the study of winding numbers. We first need a definition:

Definition 2.5.5. If $f: U \rightarrow \mathbb{C}$ is a function on an open subset U of \mathbb{C} , then we say that f is *analytic* on U if for every $z_0 \in U$ there is an $r > 0$ with $B(z_0, r) \subseteq U$ such that there is a power series $\sum_{k=0}^{\infty} a_k(z - z_0)^k$ with radius of convergence at least r and $f(z) = \sum_{k=0}^{\infty} a_k(z - z_0)^k$. An analytic function is holomorphic, as any power series is (infinitely) complex differentiable.

Proposition 2.5.6. Let U be an open set in \mathbb{C} and let $\gamma: [0, 1] \rightarrow U$ be a closed path. If $f(z)$ is a continuous function on γ^* then the function

$$I_f(\gamma, w) = \frac{1}{2\pi i} \int_{\gamma} \frac{f(z)}{z - w} dz,$$

is analytic in w .

In particular, if $f(z) = 1$ this shows that the function $w \mapsto I(\gamma, w)$ is a continuous function on $\mathbb{C} \setminus \gamma^*$, and since it is integer-valued, it is constant on the connected components of $\mathbb{C} \setminus \gamma^*$.

Proof. We wish to show that for each $z_0 \notin \gamma^*$ we can find a disk $B(z_0, \epsilon)$ within which $I_f(\gamma, w)$ is given by a power series in $(w - z_0)$. Translating if necessary we may assume $z_0 = 0$.

Now since $\mathbb{C} \setminus \gamma^*$ is open, there is some $r > 0$ such that $B(0, 2r) \cap \gamma^* = \emptyset$. We claim that $I_f(\gamma, w)$ is holomorphic in $B(0, r)$. Indeed if $w \in B(0, r)$ and $z \in \gamma^*$ it follows that $|w/z| < 1/2$. Moreover, since γ^* is compact, $M = \sup\{|f(z)| : z \in \gamma^*\}$ is finite, and hence

$$|f(z)w^n/z^{n+1}| = |f(z)||z|^{-1}|w/z|^n < \frac{M}{2r}(1/2)^n, \quad \forall z \in \gamma^*.$$

It follows from the Weierstrass M -test that the series

$$\sum_{n=0}^{\infty} \frac{f(z)w^n}{z^{n+1}} = \sum_{n=0}^{\infty} \frac{f(z)}{z} (w/z)^n = \frac{f(z)}{z} (1 - w/z)^{-1} = \frac{f(z)}{z - w}$$

viewed as a function of z , converges uniformly on γ^* to $f(z)/(z - w)$. Thus for all $w \in B(0, r)$ we have

$$I_f(\gamma, w) = \frac{1}{2\pi i} \int_{\gamma} \frac{f(z)dz}{z - w} = \sum_{n=0}^{\infty} \left(\frac{1}{2\pi i} \int_{\gamma} \frac{f(z)}{z^{n+1}} dz \right) w^n,$$

hence $I_f(\gamma, w)$ is given by a power series in $B(0, r)$ (and hence is also holomorphic there) as required. Finally, if $f = 1$, then since $I_1(\gamma, z) = I(\gamma, z)$ is integer-valued, it follows it must be constant on any connected component of $\mathbb{C} \setminus \gamma^*$ as required. \square

Remark 2.5.7. Note that since the coefficients of a power series centred at a point z_0 are given by its derivatives at that point, the proof above actually also gives formulae for the derivatives of $g(w) = I_f(\gamma, w)$ at z_0 :

$$g^{(n)}(z_0) = \frac{n!}{2\pi i} \int_{\gamma} \frac{f(z)dz}{(z - z_0)^{n+1}}.$$

Remark 2.5.8. If γ is a closed path then γ^* is compact and hence bounded. Thus there is an $R > 0$ such that the connected set $\mathbb{C} \setminus B(0, R) \cap \gamma^* = \emptyset$. It follows that $\mathbb{C} \setminus \gamma^*$ has exactly one unbounded connected component. Since

$$\left| \int_{\gamma} \frac{d\zeta}{\zeta - z} \right| \leq \ell(\gamma) \sup_{\zeta \in \gamma^*} |1/(\zeta - z)| \rightarrow 0$$

as $z \rightarrow \infty$ it follows that $I(\gamma, z) = 0$ on the unbounded component of $\mathbb{C} \setminus \gamma^*$.

Let γ be a simple closed curve. There is a theorem, known as the *Jordan Curve Theorem*, that $\mathbb{C} \setminus \gamma^*$ has precisely one bounded and one unbounded component. The bounded component is the *interior*⁸ and the unbounded component is the *exterior* of γ . Moreover, the winding number around any point from the bounded component is either 1 or -1 .

Definition 2.5.9. Let γ be as above. We say that γ is *positively oriented* if its winding number around any point from the bounded component is 1. Otherwise, it is negatively oriented. Equivalently, if w is a point from the bounded component, then γ is positively oriented if

$$\frac{1}{2\pi i} \int_{\gamma} \frac{dz}{z - w} = 1.$$

By Proposition 2.5.6 orientation does not depend on the choice of w .

Finally, we will need the following topological fact that we state without proof.



Proposition 2.5.10. Let U be a domain, γ be a simple positively oriented curve such that it and its interior are inside U and w be a point inside γ . Let $r > 0$ be such that $B(w, r)$ is inside γ and denote the positively oriented circle of radius r around w by γ_r . Then γ is homotopic to γ_r inside $U \setminus \{w\}$.

⁸Not to be confused with the interior of a set. If γ is a simple curve then its (topological) interior as defined in the Metric Spaces and elsewhere is empty. Usually, it is clear from the context what is meant by ‘interior’. Occasionally, to avoid confusion, some authors use the term ‘inside’ instead.

Chapter 3

Cauchy's Formula and its applications

3.1 Cauchy's Integral Formula

★ We are now almost ready to prove one of the most important consequences of Cauchy's theorem – the integral formula. This formula will have incredibly powerful consequences and one of the main things that distinguish real and complex analysis.

Theorem 3.1.1 (Cauchy's Integral Formula). *Suppose that $f: U \rightarrow \mathbb{C}$ is a holomorphic function on an open set U , $w \in U$ and γ is a simple positively oriented closed curve such that γ^* and the interior of γ are inside of U . Then for all w that are inside of γ we have*

$$f(w) = \frac{1}{2\pi i} \int_{\gamma} \frac{f(z)}{z-w} dz.$$

Proof. Fix w inside γ . There is r_0 such that $B(w, r_0)$ does not intersect γ^* . In particular, it means that this disc is inside γ . Take any $0 < r < r_0$. By γ_r we denote the positively oriented circle of radius r around w . By Proposition 2.5.10 γ is homotopic to γ_r inside $U \setminus \{w\}$. Since $f(z)/(z-w)$ is holomorphic in $U \setminus \{w\}$, then by the Deformation Theorem 2.4.7

$$\frac{1}{2\pi i} \int_{\gamma} \frac{f(z)}{z-w} dz = \frac{1}{2\pi i} \int_{\gamma_r} \frac{f(z)}{z-w} dz.$$

The last integral can be rewritten as

$$\begin{aligned} \frac{1}{2\pi i} \int_{\gamma_r} \frac{f(z)}{z-w} dz &= \frac{1}{2\pi i} \int_{\gamma_r} \frac{f(z) - f(w)}{z-w} dz + \frac{f(w)}{2\pi i} \int_{\gamma_r} \frac{dz}{z-w}. \\ &= \frac{1}{2\pi i} \int_{\gamma_r} \frac{f(z) - f(w)}{z-w} dz + f(w) \\ &= \frac{1}{2\pi i} \int_{\gamma_r} \frac{f(z) - f(w)}{z-w} dz + f(w). \end{aligned}$$

Since f is complex differentiable at $z = w$, the term $(f(z) - f(w))/(z - w)$ is bounded as $r \rightarrow 0$, so that by the estimation lemma its integral over γ_r tends to zero. Thus as $r \rightarrow 0$ the path integral around γ_r tends to $f(w)$. But since it is also equal to $(2\pi i)^{-1} \int_{\gamma} f(z)/(z-w) dz$, which is independent of r , we conclude that it must in fact be equal to $f(w)$. The result follows. \square

Remark 3.1.2. The same result holds for any oriented curve γ once we weight the left-hand side by the winding number of a path around the point $w \notin \gamma^*$, provided that f is holomorphic on the inside of γ .

Cauchy's integral formula has a different useful form that we state as a corollary.

Corollary 3.1.3 (Cauchy Formula for multiple curves). *Let U be a bounded domain with piecewise C^1 boundary which has finitely many components and f be a function holomorphic in the closure of U (this means that it is holomorphic in some open domain that contains the closure of U). We parametrise each boundary component of U by a contour γ_i in such way that $i\gamma_i'(t)$ is an inward normal. This means that the 'outer' boundary is positively oriented (i.e. counter-clockwise) and all 'inner' components are negatively oriented (i.e. clockwise)¹. Denoting $\int_{\partial U} = \sum \int_{\gamma_i}$ we have*

$$\int_{\partial U} f(z) dz = 0$$

and

$$\frac{1}{2\pi i} \int_{\partial U} \frac{f(z)}{z-w} dz = f(w), \quad w \in U.$$

Remark 3.1.4. We assume that there are only finitely many boundary components, but with some extra assumptions that various integrals and series make sense this assumption can be relaxed.

¹Unfortunately, this orientation of the boundary is also called the positive orientation.

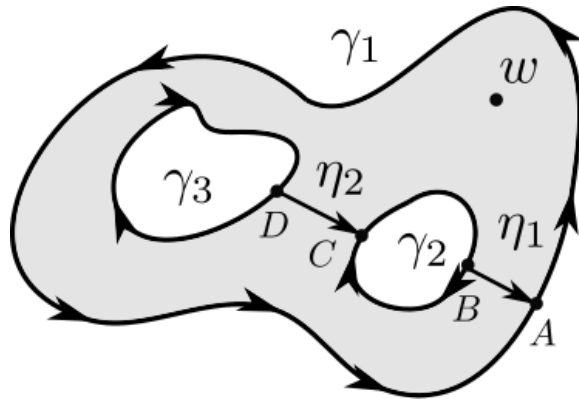

Figure 3.1: A domain with two inner components. We add two cuts between γ_1 and γ_2 and between γ_2 and γ_3 . We can apply the Cauchy Integral Formula to a curve given by concatenation of γ_1 , η_1^{-1} , γ_2 , η_1 which is the part of γ_2 from B to C , η_2^{-1} , γ_3 , η_2 , γ_2 which is the part of γ_2 from C to B and η_1 .

Proof. The idea of the proof is simple. We add a few cuts that avoid w and connect inner boundary components to each other and to the outer boundary in such a way that U without these extra curves becomes simply connected. See Figure 3.1 for details.

Let γ be the boundary of this domain. We can apply Theorem 3.1.1 to γ and obtain that

$$\frac{1}{2\pi i} \int_{\gamma} \frac{f(z)}{z-w} dz = f(w).$$

New curve γ is made of boundary components γ_i in exactly the right orientation and extra cuts η_i that appear twice with different orientations, to their contributions to the integral cancel out. This completes the proof. \square

Remark 3.1.5. We prove the Cauchy Integral Formula using the Deformation Theorem which we have not proved completely (although there is a proof in the Appendix and most of Complex Analysis textbooks will contain a proof). It is impossible to prove Cauchy's Formula without the Deformation or very careful geometric/topological analysis of piecewise C^1 curves². Alternatively, we can restrict the set of contours γ for which we prove the theorem. For most applications, it is enough to consider only circular curves.

²This is non-trivial, since, for example, they could have infinitely many points of self-intersection or they could intersect a straight line at infinitely many points



Then the only thing that we have to prove is that integrals along two circles are the same. The annular domain can be split into the union of star-like domains for which we know the existence of a primitive, so these smaller contour integrals vanish and this way we can prove the result for circles. See Figure 3.1.5 for an illustration and some extra explanations.

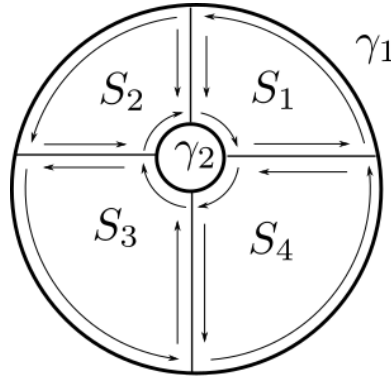

Figure 3.2: An annular domain between two positively oriented circles γ_1 and γ_2 can be split into four sectors S_1, \dots, S_4 . All domains S_i are star-like so integrals along their boundaries vanish. Integrals along extra cuts cancel out and we are left with $\int_{\gamma_1} f + \int_{\gamma_2^-} f = 0$. This means that integrals along both circles are equal.

3.2 Homotopy version of Cauchy's theorem

This section is non-examinable. It provides an alternative approach to Cauchy's theorems. This section was mostly written by Kevin McGerty. I am grateful to him for writing this up and bringing this approach to my attention³.

3.2.1 Cycles

It is useful to extend the notion of integrating functions over paths to integration over *cycles*, where a cycle is just a formal sum of paths. More precisely we have the following:

³This approach is based on Dixon, John D. "textitA brief proof of Cauchy's integral theorem." *Proceedings of the American Mathematical Society* 29.3 (1971): 625-626. and its refinement in Loeb, Peter A. "A note on Dixon's proof of Cauchy's Integral Theorem." *The American Mathematical Monthly* 98.3 (1991): 242-244.

Definition 3.2.1. A *cycle* Γ is a finite formal sum of closed paths. That is, $\Gamma = \sum_{i=1}^k m_i \gamma_i$ where $m_i \in \mathbb{Z} \setminus \{0\}$ and γ_i is a closed path, for each i , $1 \leq i \leq k$. If Γ is a cycle then we define the *support* of Γ to be $\Gamma^* := \bigcup_{i=1}^k \gamma_i^*$. Given a cycle Γ , we define, for any piecewise \mathcal{C}^1 -function f defined on Γ^* , that integral over Γ to be

$$\int_{\Gamma} f(z) dz = \sum_{i=1}^k m_i \int_{\gamma_i} f(z) dz$$

In particular, $I(\Gamma, z_0) = \sum_{i=1}^k m_i I(\gamma_i, z_0)$. We also define the *inside* and *length* of Γ to be

$$\text{ins}(\Gamma) := \{z \in \mathbb{C} : z \notin \Gamma^* \text{ and } I(\Gamma, z) \neq 0\} \quad \ell(\Gamma) := \sum_{i=1}^k |m_i| \ell(\gamma_i).$$

Note that the $I(f, -\gamma) = I(f, \gamma^-)$ where γ^- denotes the opposite path γ^- . Many results for integrating over paths extend trivially to integrals over cycles – for example Proposition 2.5.6 immediately implies the corresponding statement for cycles because finite linear combinations of holomorphic functions are holomorphic. The proof Lemma 3.2.3 below gives a detailed example of how such an extension can be established by induction.

Example 3.2.2. If $\gamma_1 = r_1 \exp(2\pi it)$ and $\gamma_2 = r_2 \exp(2\pi it)$ where $r_2 < r_1$ and we set $\Gamma = \gamma_1 - \gamma_2$, then $\mathbb{C} \setminus \Gamma^*$ has three connected components: the open disc $B(0, r_2)$ (in which $I(\Gamma, z) = I(\gamma_1, z) - I(\gamma_2, z) = 1 - 1 = 0$), the unbounded component $\{z \in \mathbb{C} : |z| \geq r_1\}$, and the inside of Γ :

$$\text{ins}(\Gamma) = \{z \in \mathbb{C} : r_2 < |z| < r_1\}$$

and for $z \in \text{ins}(\Gamma)$ we have $I(\Gamma, z) = 1$.

The following lemma means that a cycle can be perturbed in such a way that it avoids a given point but all integrals stay the same.

Lemma 3.2.3. *Let Γ is a cycle in a domain U and suppose $z_0 \in \Gamma^*$. Then there is a cycle Σ such that $z_0 \notin \Sigma^*$ and $\int_{\Sigma} f = \int_{\Gamma} f$ for every holomorphic function $f: U \rightarrow \mathbb{C}$.*

Proof. Use induction on $k = k(\Gamma)$ where k is the smallest positive integer such that Γ can be written in the form $\sum_{i=1}^k m_i \gamma_i$. If we assume the result is known for all cycles Γ' with $k(\Gamma') < k(\Gamma)$ then if $\Gamma = \sum_{i=1}^k m_i \gamma_i$, let $\Gamma' =$

$\sum_{i=1}^{k-1} m_i \gamma_i$ and let Σ_1 be a cycle such that $z_0 \notin \Sigma_1^*$ and $\int_{\Sigma_1} f dz = \int_{\Gamma_1} f dz$ for all holomorphic functions f defined on U .

Now let $\gamma = \gamma_k$. If $\gamma(t) = z_0$ for all t then we may simply set $\Sigma = \Sigma'$. Otherwise, there is some $w \in \gamma^*$ with $w \neq z_0$ and by shifting the parametrization appropriately, we may assume that $\gamma(0) = w$.

Let $r > 0$ be such that $B(z_0, r) \subseteq U$ and $|w - z_0| > r$. Since $[0, 1]$ is compact, γ is uniformly continuous, hence there is some $N > 0$ such that if $|s - t| < 1/N$ then $|\gamma(s) - \gamma(t)| < r$. Thus if the image $\gamma([k/N, (k+1)/N])$ of the interval $[k/N, (k+1)/N]$ contains z_0 , then $\gamma([k/N, (k+1)/N]) \subseteq B(z_0, r)$. Let $0 = x_0 < x_1 < \dots < x_m = 1$ be the partition of $[0, 1]$ obtained by taking the x_i s to be $\{k/N : \gamma(k/N) \neq z_0, 0 \leq k \leq N\}$. Now suppose we have $\gamma(t) = z_0$ for some $t \in (x_i, x_{i+1})$. Then $\gamma|_{[x_i, x_{i+1}]}$ lies in $B(z_0, r)$, and by Lemma 3.2.4 below with $a = x_i, b = x_{i+1}$, we may replace it with a path in $B(z_0, r) \setminus \{z_0\}$. Making such an alteration to the path on each such interval yields a path σ which does not pass through z_0 and by Cauchy's theorem for the disk, $\int_\gamma f = \int_\sigma f$ for all holomorphic functions f . Thus setting $\Sigma = \Sigma_1 + m_k \sigma$ gives the required cycle. \square

The following lemma is used in the induction step above. It allows us to deform a single curve so that it avoids a given point. The main idea of the proof is simple. Although a continuous curve can intersect a point infinitely many times, by uniform continuity, there are only finitely many arcs that intersect that point and have sufficiently large diameter. We can replace all these arcs by circular arcs.

Lemma 3.2.4. *If $\gamma: [a, b] \rightarrow \mathbb{C}$ is a piece-wise \mathcal{C}^1 path with image contained in the open ball $B(z_0, r)$ and $\gamma(a) \neq z_0 \neq \gamma(b)$, then there is a path $\gamma_1: [a, b] \rightarrow B(z_0, r)$ with $\gamma_1(a) = \gamma(a)$, $\gamma_1(b) = \gamma(b)$ and $\gamma_1(t) \neq z_0$ for all $t \in (a, b)$.*

Proof. By translation and scaling we may assume that $z_0 = 0$ and $r = 1$. Replacing, if necessary, γ with $\gamma^-: [a, b] \rightarrow \mathbb{C}$ where $\gamma^-(t) = \gamma(a + b - t)$ we may assume that $0 < |\gamma(a)| \leq |\gamma(b)|$. If $|\gamma(t)| \geq |\gamma(a)|$ for all $t \in [0, 1]$ then we may take $\gamma_1 = \gamma$. Otherwise we may find some $s_0 \in [a, b]$ with $|\gamma(s_0)| < |\gamma(a)|$ so that if we set

$$L = \{t \in [a, b] : |\gamma(s)| \geq |\gamma(a)| \forall s \in [a, t]\}, \quad U = \{t : |\gamma(s)| \geq |\gamma(a)| \forall s \in [t, b]\}.$$

Then $a \in L \subseteq [a, s_0]$ and $b \in U \subseteq (s_0, b]$ and hence $a \leq t_0 := \sup(L) < t_1 := \inf(U) \leq b$. Since $t \mapsto |\gamma(t)|$ is continuous we must have $|\gamma(t_0)| = |\gamma(a)| =$

$|\gamma(t_1)|$. If $\alpha, \beta \in [-\pi, \pi)$ are given by $\gamma(t_0) = |\gamma(a)|.e^{i\alpha}$ and $\gamma(t_1) = |\gamma(a)|.e^{i\beta}$ then let $g: [t_0, t_1] \rightarrow \mathbb{R}$ and $\gamma_1: [0, 1] \rightarrow \mathbb{C}$ be given by

$$g(t) = \frac{t_1 - t}{t_1 - t_0}\alpha + \frac{t - t_0}{t_1 - t_0}\beta, \quad \gamma_1(t) = \begin{cases} \gamma(t), & t \in [a, t_0] \cup [t_1, b] \\ |\gamma(a)|\exp(ig(t)), & t_0 \leq t \leq t_1 \end{cases}$$

then γ_1 is continuous, since it is evidently so on each of $[a, t_0] \cup [t_1, b]$ and $[t_0, t_1]$, and moreover $|\gamma_1(t)| \geq d$ for all $t \in [a, b]$. \square

3.2.2 The homology form of Cauchy's theorem

We can now state and prove what is known as the *homology form* of Cauchy's theorem.

Theorem 3.2.5. *Let $f: U \rightarrow \mathbb{C}$ be a holomorphic function and let Γ be a cycle in U whose inside lies entirely in U , that is $I(\Gamma, z) = 0$ for all $z \notin U$. Then Cauchy's theorem and Integral Formula hold, that is, we have,*

$$i) \int_{\Gamma} f(\zeta)d\zeta = 0; \quad ii) \quad \frac{1}{2\pi i} \int_{\Gamma} \frac{f(\zeta)}{\zeta - z} d\zeta = I(\Gamma, z)f(z), \quad \forall z \in U \setminus \Gamma^*.$$

Proof. Note first that, given f and $z \in U \setminus \Gamma^*$ as in the statement of the theorem, if we apply *ii)* (the generalised Integral Formula) to the holomorphic function $f_1(\zeta) = (z - \zeta)f(\zeta)$ in place of $f(\zeta)$, then we recover *i)*, the general form of Cauchy's theorem. Hence it suffices to prove the Integral formula. Clearly this is equivalent to showing $F(z) \equiv 0$ on U where we let

$$G(z) := \frac{1}{2\pi i} \int_{\Gamma} \frac{f(\zeta)}{\zeta - z} d\zeta, \quad z \in \mathbb{C} \setminus \Gamma^*, \quad F(z) := G(z) - f(z)I(\Gamma, z).$$

But if we set, for fixed $z \in U$, we define $g_z: U \setminus \{z\} \rightarrow \mathbb{C}$ by setting $g_z(\zeta) := (f(\zeta) - f(z))/(\zeta - z)$ then by Lemma 2.5.4 we have

$$\begin{aligned} F(z) &= G(z) - \frac{f(z)}{2\pi i} \int_{\Gamma} \frac{d\zeta}{\zeta - z} = \int_{\Gamma} \frac{f(\zeta) - f(z)}{\zeta - z} d\zeta \\ &= \frac{1}{2\pi i} \int_{\Gamma} g_z(\zeta) d\zeta, \quad z \in U \setminus \Gamma^*. \end{aligned} \tag{3.2.1}$$

Now Proposition 2.5.6 shows that $G(z)$ and $I(\Gamma, z)$ are holomorphic for all $z \in \mathbb{C} \setminus \Gamma^*$, thus we see from the first expression for $F(z)$ in (3.2.1) that it is holomorphic on $U \setminus \Gamma^*$. Now for fixed z , $g_z(\zeta)$ is clearly a holomorphic function of ζ on $U \setminus \{z\}$ and, as $\lim_{\zeta \rightarrow z} g_z(\zeta) = f'(z)$, it extends to a continuous function on U , which we also denote by g_z , where we define

$g_z(z) := f'(z)$. Moreover, since it is continuous at $\zeta = z$, g_z is bounded near z , Riemann's removable singularities theorem shows that this extension is in fact holomorphic as a function of ζ on all of U . But then we may extend the definition of F from $U \setminus \Gamma^*$ to all of U by setting $F(z) := \int_{\Gamma} g_z(\zeta) d\zeta$.

We claim that this extension of F is holomorphic on U : Indeed if $z_0 \in \Gamma^*$, then since $g_z(\zeta)$ is holomorphic, Lemma 3.2.3 shows that there is a cycle $\Sigma \subseteq U$ not containing z_0 such that $\int_{\Sigma} g_z(\zeta) d\zeta = \int_{\Gamma} g_z(\zeta) d\zeta$. But then replacing Γ by Σ in (3.2.1) and applying the same reasoning as above we see that F is holomorphic on $U \setminus \Sigma^*$ and so in particular at z_0 . Since z_0 was arbitrary, it follows that F is holomorphic on all of U .

Let $V = \mathbb{C} \setminus (\Gamma^* \cup \text{ins}(\Gamma))$. Since $G(z)$ is holomorphic on all of $\mathbb{C} \setminus \Gamma^*$ it certainly restricts to a holomorphic function on V . Now by assumption, $\Gamma \cup \text{ins}(\Gamma) \subseteq U$ and hence $U \cup V = \mathbb{C}$. Moreover, if $z \in U \cap V$, that is, $z \in U$ but neither inside Γ nor on Γ^* , then by definition, $F(z) = G(z)$.⁴ It follows that if we let

$$H: \mathbb{C} \rightarrow \mathbb{C}, \quad H(z) := \begin{cases} F(z), & z \in U \\ G(z), & z \in V \end{cases}$$

then H is a well-defined entire function (that is, it is holomorphic on all of \mathbb{C}) and clearly $F(z) \equiv 0$ on U if $H(z) \equiv 0$ on \mathbb{C} . But $H(z) = G(z)$ for large enough z and Proposition 2.5.6 shows that $G(z) \rightarrow 0$ as $z \rightarrow \infty$, hence H defines a bounded entire function which is constant, and hence necessarily 0, by Liouville's theorem. \square

Remark 3.2.6. The above proof of the homology form of Cauchy's theorem uses Liouville's theorem, Riemann's removable singularities theorem, and Lemma 3.2.3, all of which we proved using Cauchy's theorem for a disk.⁵ The proof thus does not rely on the homotopy form of Cauchy's theorem, or indeed even the notion of a homotopy in the first place!

Example 3.2.7. The cycle of Example 3.2.2 shows that $\int_{\Gamma} \frac{f(\zeta)}{\zeta - z} d\zeta = f(z)$ for $z \in A = \{z \in \mathbb{C} : r_1 < |z| < r_2\}$, and using the geometric series for $1/(1 - z/\zeta)$ and $1/(1 - \zeta/z)$ for the integral around γ_2 and γ_1 respectively then yields the Laurent expansion for f in the annulus A , avoiding the artificial introduction of additional cuts in the domain.

⁴Note however that by the above, F and G will in general *not* agree on the inside of Γ .

⁵In particular, Riemann's result follows from the analyticity of complex differentiable functions: if f is holomorphic on $U \setminus \{0\}$ and bounded near 0 then $g(z) = z^2 f(z)$ is complex-differentiable at $z = 0$ and hence given by a power series. But then $f(z) = g(z)/z^2$ is also.

3.3 Applications of the Integral Formula

★ *Remark 3.3.1.* Note that Cauchy’s integral formula can be interpreted as saying the value of $f(w)$ for w inside the circle is obtained as the “convolution” of f and the function $1/(z-w)$ on the boundary circle. Since the function $1/(z-w)$ is infinitely differentiable one can use this to show that f itself is infinitely differentiable as we will shortly show. If you take the Integral Transforms, you will see convolution play a crucial role in the theory of transforms. In particular, the convolution of two functions often inherits the “good” properties of either. We next show that in fact the formula implies a strong version of Taylor’s Theorem.

Corollary 3.3.2. *If $f: U \rightarrow \mathbb{C}$ is holomorphic on an open set U , then for any $z_0 \in U$, $f(z)$ is equal to its Taylor series at z_0 and the Taylor series converges on any open disk centred at z_0 lying in U . Moreover the derivatives of f at z_0 are given by*

$$f^{(n)}(z_0) = \frac{n!}{2\pi i} \int_{\gamma(z_0, r)} \frac{f(z)}{(z-z_0)^{n+1}} dz, \quad (3.3.1)$$

for any $r < R$, where R is such that $B(z_0, R) \subset U$.

Proof. This follows immediately from the Integral formula, the proof of Proposition 2.5.6, and Remark 2.5.7. The integral formulae of Equation 3.3.1 for the derivatives of f are also referred to as *Cauchy’s Integral Formulae*. \square

Definition 3.3.3. Recall that a function which is locally given by a power series is said to be *analytic*. We have thus shown that any holomorphic function is actually analytic, and from now on we may use the terms interchangeably (as you may notice is common practice in many textbooks).

One famous application of the Integral formula is known as Liouville’s theorem, which will give an easy proof of the Fundamental Theorem of Algebra⁶. We say that a function $f: \mathbb{C} \rightarrow \mathbb{C}$ is *entire* if it is complex differentiable on the whole complex plane.

⁶Which, when it comes down to it, isn’t really a theorem in algebra. The most “algebraic” proof of that I know uses Galois theory, which you can learn about in Part B. But it also uses the fact that any real polynomial of odd degree has a real root. This is a simple corollary of the intermediate value theorem, which in its turn depends on the completeness of \mathbb{R} which is not an algebraic property at all.

Theorem 3.3.4 (Liouville). *Let $f: \mathbb{C} \rightarrow \mathbb{C}$ be an entire function. If f is bounded then it is constant.*

Proof. Suppose that $|f(z)| \leq M$ for all $z \in \mathbb{C}$. Let $\gamma_R(t) = Re^{2\pi it}$ be the circular path centred at the origin with radius R . Then for $R > |w|$ the integral formula shows

$$\begin{aligned} |f(w) - f(0)| &= \left| \frac{1}{2\pi i} \int_{\gamma_R} f(z) \left(\frac{1}{z-w} - \frac{1}{z} \right) dz \right| \\ &= \frac{1}{2\pi} \left| \int_{\gamma_R} \frac{wf(z)}{z(z-w)} dz \right| \\ &\leq \frac{2\pi R}{2\pi} \sup_{z:|z|=R} \left| \frac{wf(z)}{z(z-w)} \right| \\ &\leq R \frac{M|w|}{R(R-|w|)} = \frac{M|w|}{R-|w|}, \end{aligned}$$

Thus letting $R \rightarrow \infty$ we see that $|f(w) - f(0)| = 0$, so that f is constant as required. \square



Remark 3.3.5. Liouville's theorem is one more manifestation of the unique properties of holomorphic functions. First of all, there is nothing like this in real analysis. For example, $f(x) = 1/(1+x^2)$ is real-analytic in the entire \mathbb{R} , but it is bounded. Secondly, this is one of the first examples of a dichotomy which often appears in complex analysis. In many cases objects are either as good as they could be or as bad as they could be but nothing in between. For example, here we see that an entire function f is either constant or there is $z_n \rightarrow \infty$ such that $f(z_n) \rightarrow \infty$. Later we will see that the behaviour at infinity is even more interesting.

Theorem 3.3.6. *Suppose that $p(z) = \sum_{k=0}^n a_k z^k$ is a non-constant polynomial where $a_k \in \mathbb{C}$ and $a_n \neq 0$. Then there is a $z_0 \in \mathbb{C}$ for which $p(z_0) = 0$.*

Proof. By rescaling p we may assume that $a_n = 1$. If $p(z) \neq 0$ for all $z \in \mathbb{C}$ it follows that $f(z) = 1/p(z)$ is an entire function (since p is clearly entire). We claim that f is bounded. Indeed since it is continuous it is bounded on any disc $\bar{B}(0, R)$, so it suffices to show that $|f(z)| \rightarrow 0$ as $z \rightarrow \infty$, that is, to show that $|p(z)| \rightarrow \infty$ as $z \rightarrow \infty$. But we have

$$|p(z)| = \left| z^n + \sum_{k=0}^{n-1} a_k z^k \right| = |z|^n \left(\left| 1 + \sum_{k=0}^{n-1} \frac{a_k}{z^{n-k}} \right| \right) \geq |z|^n \left(1 - \sum_{k=0}^{n-1} \frac{|a_k|}{|z|^{n-k}} \right).$$

Since $1/|z|^m \rightarrow 0$ as $|z| \rightarrow \infty$ for any $m \geq 1$ it follows that for sufficiently large $|z|$, say $|z| \geq R$, we will have $1 - \sum_{k=0}^{n-1} \frac{|a_k|}{|z|^{n-k}} \geq 1/2$. Thus for $|z| \geq R$ we have $|p(z)| \geq \frac{1}{2}|z|^n$. Since $|z|^n$ clearly tends to infinity as $|z|$ tends to infinity, it follows $|p(z)| \rightarrow \infty$ as required. \square

Remark 3.3.7. The crucial point of the above proof is that one term of the polynomial – the leading term in this case – dominates the behaviour of the polynomial for large values of z . All proofs of the fundamental theorem hinge on essentially this point. Note that $p(z_0) = 0$ if and only if $p(z) = (z - z_0)q(z)$ for a polynomial $q(z)$, thus by induction on the degree we see that the theorem implies that a polynomial over \mathbb{C} factors into a product of degree one polynomials.

We end this section with a kind of converse to Cauchy's theorem:

Theorem 3.3.8 (Morera). *Suppose that $f: U \rightarrow \mathbb{C}$ is a continuous function on an open subset $U \subseteq \mathbb{C}$. If for any closed path $\gamma: [a, b] \rightarrow U$ we have $\int_\gamma f(z)dz = 0$, then f is holomorphic.*

Proof. By Theorem 2.2.16 we know that f has a primitive $F: U \rightarrow \mathbb{C}$. But then F is holomorphic on U and so infinitely differentiable on U , thus in particular $f = F'$ is also holomorphic. \square

Remark 3.3.9. One can prove variants of the above theorem: If U is a star-like domain for example, then our proof of Cauchy's theorem for such domains shows that $f: U \rightarrow \mathbb{C}$ has a primitive (and hence will be differentiable itself) provided $\int_T f(z)dz = 0$ for every triangle in U . In fact, the assumption that $\int_T f(z)dz = 0$ for all triangles whose interior lies in U suffices to imply f is holomorphic for *any* open subset U : To show f is holomorphic on U , it suffices to show that f is holomorphic on $B(a, r)$ for each open disk $B(a, r) \subset U$. But this follows from the above as disks are star-like (in fact convex). It follows that we can characterize the fact that $f: U \rightarrow \mathbb{C}$ is holomorphic on U by an integral condition: $f: U \rightarrow \mathbb{C}$ is holomorphic if and only if for all triangles T which bound a solid triangle \mathcal{T} with $\mathcal{T} \subset U$, the integral $\int_T f(z)dz = 0$.

This characterization of the property of being holomorphic has some important consequences. We first need a definition:

Definition 3.3.10. Let U be an open subset of \mathbb{C} . If (f_n) is a sequence of functions defined on U , we say $f_n \rightarrow f$ *uniformly on compacts* if for every compact subset K of U , the sequence $(f_n|_K)$ converges uniformly to $f|_K$. Note that in this case, f is continuous if the f_n are: Indeed to see that f is

continuous at $a \in U$, note that since U is open, there is some $r > 0$ with $B(a, r) \subseteq U$. But then $K = \bar{B}(a, r/2) \subseteq U$ and $f_n \rightarrow f$ uniformly on K , whence f is continuous on K , and so certainly it is continuous at a .

Example 3.3.11. Convergence of power series $f(z) = \sum_{k=0}^{\infty} a_k z^k$ is a basic example of convergence on compacts: if R is the radius of convergence of $f(z)$ the partial sums $s_n(z)$ of the power series $B(0, R)$ converge uniformly on compacts in $B(0, R)$. The convergence is *not* necessarily uniform on $B(0, R)$, as the example $f(z) = \sum_{n=0}^{\infty} z^n$ shows. Nevertheless, since $B(0, R) = \bigcup_{r < R} \bar{B}(0, r)$ is the union of its compact subsets, many of the good properties of the polynomial functions $s_n(z)$ are inherited by the power series because the convergence is uniform on compact subsets.

Proposition 3.3.12. *Suppose that U is a domain and the sequence of holomorphic functions $f_n: U \rightarrow \mathbb{C}$ converges to $f: U \rightarrow \mathbb{C}$ uniformly on compacts in U . Then f is holomorphic.*

Proof. Note by the above that f is continuous on U . Since the property of being holomorphic is local, it suffices to show for each $w \in U$ that there is a ball $B(w, r) \subseteq U$ within which f is holomorphic. Since U is open, for any such w we may certainly find $r > 0$ such that $B(w, r) \subseteq U$. Then as $B(w, r)$ is convex, Cauchy's theorem for a star-like domain shows that for every closed path $\gamma: [a, b] \rightarrow B(w, r)$ whose image lies in $B(w, r)$ we have $\int_{\gamma} f_n(z) dz = 0$ for all $n \in \mathbb{N}$.

But $\gamma^* = \gamma([a, b])$ is a compact subset of U , hence $f_n \rightarrow f$ uniformly on γ^* . It follows that

$$0 = \int_{\gamma} f_n(z) dz \rightarrow \int_{\gamma} f(z) dz,$$

so that the integral of f around any closed path in $B(w, r)$ is zero. But then Morera's Theorem 3.3.8 shows that f is holomorphic. □

3.4 The identity theorem

The fact that any complex differentiable function is in fact analytic has some very surprising consequences – the most striking of which is perhaps captured by the “Identity theorem”. This says that if f, g are two holomorphic functions defined on a domain U and we let $S = \{z \in U : f(z) = g(z)\}$ be the locus on which they are equal, then if S has a limit point in U it must actually be all of U . Thus for example if there is a disk $B(a, r) \subseteq U$ on

which f and g agree (no matter how small r is), then in fact they are equal on all of U ! The key to the proof of the Identity theorem is the following result on the zeros of a holomorphic function:

Proposition 3.4.1. *Let U be an open set and suppose that $g: U \rightarrow \mathbb{C}$ is holomorphic on U . Let $S = \{z \in U : g(z) = 0\}$. If $z_0 \in S$ then either z_0 is isolated in S (so that g is non-zero in some disk about z_0 except at z_0 itself) or $g = 0$ on a neighbourhood of z_0 . In the former case there is a unique integer $k > 0$ and holomorphic function g_1 such that $g(z) = (z - z_0)^k g_1(z)$ where $g_1(z_0) \neq 0$.*

Proof. Pick any $z_0 \in U$ with $g(z_0) = 0$. Since g is analytic at z_0 , if we pick $r > 0$ such that $\bar{B}(z_0, r) \subseteq U$, then we may write

$$g(z) = \sum_{k=0}^{\infty} c_k (z - z_0)^k,$$

for all $z \in B(z_0, r) \subseteq U$, where the coefficients c_k are given as in Theorem 3.3.2. Now if $c_k = 0$ for all k , it follows that $g(z) = 0$ for all $z \in B(z_0, r)$. Otherwise, we set $k = \min\{n \in \mathbb{N} : c_n \neq 0\}$ (where since $g(z_0) = 0$ we have $c_0 = 0$ so that $k \geq 1$). Then if we let $g_1(z) = (z - z_0)^{-k} g(z)$, clearly $g_1(z)$ is holomorphic on $U \setminus \{z_0\}$, but since in $B(z_0, r)$ we have $g_1(z) = \sum_{n=0}^{\infty} c_{k+n} (z - z_0)^n$, it follows if we set $g_1(z_0) = c_k \neq 0$ then g_1 becomes a holomorphic function on all of U . Since g_1 is continuous at z_0 and $g_1(z_0) \neq 0$, there is an $\epsilon > 0$ such that $g_1(z) \neq 0$ for all $z \in B(z_0, \epsilon)$. But $(z - z_0)^k$ vanishes only at z_0 , hence it follows that $g(z) = (z - z_0)^k g_1(z)$ is non-zero on $B(z_0, \epsilon) \setminus \{z_0\}$, so that z_0 is isolated.

Finally, to see that k is unique, suppose that $g(z) = (z - z_0)^k g_1(z) = (z - z_0)^l g_2(z)$ say with $g_1(z_0)$ and $g_2(z_0)$ both nonzero. If $k < l$ then $g(z)/(z - z_0)^k = (z - z_0)^{l-k} g_2(z)$ for all $z \neq z_0$, hence as $z \rightarrow z_0$ we have $g(z)/(z - z_0)^k \rightarrow 0$, which contradicts the assumption that $g_1(z) \neq 0$. By symmetry, we also cannot have $k > l$ so $k = l$ as required. \square

Remark 3.4.2. The integer k in the previous proposition is called the *multiplicity* of the zero of g at $z = z_0$ (or sometimes the *order of vanishing*).

Theorem 3.4.3. (*Identity theorem*): *Let U be a domain and suppose that f_1, f_2 are holomorphic functions defined on U . Then if $S = \{z \in U : f_1(z) = f_2(z)\}$ has a limit point in U , we must have $S = U$, that is $f_1(z) = f_2(z)$ for all $z \in U$.*

Proof. Let $g = f_1 - f_2$, so that $S = g^{-1}(\{0\})$. We must show that if S has a limit point then $S = U$. Since g is clearly holomorphic in U , by Proposition 3.4.1 we see that if $z_0 \in S$ then either z_0 is an isolated point of S or it lies in an open ball contained in S . It follows that $S = V \cup T$ where $T = \{z \in S : z \text{ is isolated}\}$ and $V = \text{int}(S)$ is open. But since g is continuous, $S = g^{-1}(\{0\})$ is closed in U , thus $V \cup T$ is closed, and so $\text{Cl}_U(V)$, the closure⁷ of V in U , lies in $V \cup T$. However, by definition, no limit point of V can lie in T so that $\text{Cl}_U(V) = V$, and thus V is open and closed in U . Since U is connected, it follows that $V = \emptyset$ or $V = U$. In the former case, all the zeros of g are isolated and S has no limit points. In the latter case, $V = S = U$ as required. □

Remark 3.4.4. The requirement in the theorem that S have a limit point lying in U is essential: If we take $U = \mathbb{C} \setminus \{0\}$ and $f_1 = \exp(1/z) - 1$ and $f_2 = 0$, then the set S is just the points where f_1 vanishes on U . Now the zeros of f_1 have a limit point at $0 \notin U$ since $f_1(1/(2\pi in)) = 0$ for all $n \in \mathbb{N}$, but certainly f_1 is not identically zero on U !

3.5 Isolated singularities

We now wish to study singularities of holomorphic functions. We are mainly interested in isolated singularities.

Definition 3.5.1. Let $f: U \rightarrow \mathbb{C}$ be a function, where U is open. We say that $z_0 \in \bar{U}$ is a *regular* point of f if f is holomorphic at z_0 . Otherwise, we say that z_0 is *singular*.

We say that z_0 is an *isolated singularity* if f is holomorphic on $B(z_0, r) \setminus \{z_0\}$ for some $r > 0$.

Definition 3.5.2. A function on an open set U which has only isolated singularities all of which are poles is called a *meromorphic* function on U . (Thus, strictly speaking, it is a function only defined on the complement of the poles in U .)

We will use the following classification of isolated singularities:

Definition 3.5.3. Let z_0 be an isolated singularity of function f . We say that z_0 is

⁷I use the notation $\text{Cl}_U(V)$, as opposed to \bar{V} , to emphasize that I mean the closure of V in U , not in \mathbb{C} , that is, $\text{Cl}_U(V)$ is equal to the union of V with the limits points of V which lie in U .

- An *removable singularity* if there is a function g holomorphic in $B(z_0, r)$ for some $r > 0$ such that $f(z) = g(z)$ in $B(z_0, r) \setminus \{z_0\}$.
- A *pole of order n* if there is a function g holomorphic in $B(z_0, r)$ for some $r > 0$ such that $g(z_0) \neq 0$ and $f(z) = (z - z_0)^{-n}g(z)$ in $B(z_0, r) \setminus \{z_0\}$.
- An *essential singularity* otherwise.

Remark 3.5.4. Note that the definition of the pole of order n is very similar to the definition of the zero with multiplicity n .

Example 3.5.5. Let $f(z) = z/z$. This function is not even defined at $z = 0$ but it is equal to 1 otherwise and clearly holomorphic in $\mathbb{C} \setminus \{0\}$. So $z_0 = 0$ is an isolated singularity. This is clearly a removable singularity since $g = 1$ is holomorphic everywhere and equal to f outside of 0.

Examples of removable singularities can be more involved:

Example 3.5.6. Let $f(z) = \sin(z)/z$. Again, it is easy to see that $z_0 = 0$ is an isolated singularity. It is removable since the function

$$g(z) = 1 - \frac{z^2}{3!} + \frac{z^4}{5!} - \dots$$

is entire and coincides with f outside of z_0 .

In a similar way we can construct a pole.

Example 3.5.7. Let $f(z) = \sin(z)/z^{n+1}$. This function has a pole of order n at $z_0 = 0$. It is easy to see that for $z \neq 0$ we have $f(z) = g(z)/z^n$ where g is the entire function from the previous example. Obviously $g(0) = 1 \neq 0$.

A typical essential singularity is given by the following example.

Example 3.5.8. Let $f(z) = \sin(1/z)$. This function is holomorphic in $\mathbb{C} \setminus \{0\}$. It is not too difficult to show that 0 is neither a removable singularity nor a pole, so it must be an essential singularity. A bit later we will have alternative characterizations of singularities that will be more suitable for determining their types.

The main tool for studying singularities is the following theorem which is a generalization of Taylor's theorem.

Theorem 3.5.9 (Laurent's Theorem). *Suppose that $0 < r < R$ and*

$$A = A(z_0, r, R) = \{z : r < |z - z_0| < R\}$$

is an annulus centred at z_0 . If $f: U \rightarrow \mathbb{C}$ is holomorphic on an open set U which contains A , then there exist $c_n \in \mathbb{C}$ such that

$$f(z) = \sum_{n=-\infty}^{\infty} c_n (z - z_0)^n, \quad \forall z \in A.$$

The series converges for all $z \in A$ and it converges uniformly for all $z \in A(z_0, r', R')$ where $r < r' < R' < R$. The series is called the Laurent series of f .

Moreover, the c_n are unique and are given by the following formulae:

$$c_n = \frac{1}{2\pi i} \int_{\gamma_s} \frac{f(z)}{(z - z_0)^{n+1}} dz,$$

where $s \in [r, R]$ and for any $s > 0$ we set $\gamma_s(t) = z_0 + se^{2\pi it}$.

Remark 3.5.10. Since we have a formula for Laurent coefficients in terms of f , it means that the Laurent expansion is unique. If two series converge to the same function then they must coincide term-by-term.

Remark 3.5.11. By the Deformation Theorem 2.4.7 circular contour γ_s can be replaced by any other curve homotopic to γ_s . In particular, by any other positively oriented simple curve in A .

Remark 3.5.12. If f is holomorphic in $B(z_0, R)$ then for $n < 0$ the integrand in the formula for c_n is holomorphic, hence $c_n = 0$ for all $n < 0$. For $n \geq 0$ formulas for c_n are exactly the same as in Taylor's theorem so in this case the Laurent series is the same as the Taylor series.

Proof. By Corollary 3.1.3 for any $w \in A$ we have

$$f(w) = \frac{1}{2\pi i} \int_{\gamma_R} \frac{f(z)}{z - w} dz - \frac{1}{2\pi i} \int_{\gamma_r} \frac{f(z)}{z - w} dz.$$



Note that here both boundary components are counter-clockwise oriented but in Corollary 3.1.3 the inner component is clockwise oriented. This is compensated by the minus sign in front of the second integral.

But now the result follows in the same way as we showed holomorphic functions were analytic: if we fix w , then, for $|w| < R = |z|$ we have

$$\frac{1}{z - w} = \sum_{n=0}^{\infty} w^n / z^{n+1}$$

and for an $|w| < R - \epsilon = |z| - \epsilon$ the series converges uniformly z for any $\epsilon > 0$. It follows that

$$\int_{\gamma_R} \frac{f(z)}{z-w} dz = \int_{\gamma_R} \sum_{n=0}^{\infty} \frac{f(z)w^n}{z^{n+1}} dz = \sum_{n \geq 0} \left(\int_{\gamma_R} \frac{f(z)}{z^{n+1}} dz \right) w^n.$$

for all $w \in A$. Similarly since for $|z| = r < |w|$ we have⁸

$$\frac{1}{w-z} = \sum_{n \geq 0} z^n / w^{n+1} = \sum_{n=-1}^{-\infty} w^n / z^{n+1},$$

again converging uniformly when $|z| = r < |w| - \epsilon$ for $\epsilon > 0$, we see that

$$\int_{\gamma_r} \frac{f(z)}{w-z} dz = \int_{\gamma_r} \sum_{n=-1}^{-\infty} f(z)w^n / z^{n+1} dz = \sum_{n=-1}^{-\infty} \left(\int_{\gamma_r} \frac{f(z)}{z^{n+1}} dz \right) w^n.$$

Thus taking $(c_n)_{n \in \mathbb{Z}}$ as in the statement of the theorem, we see that

$$f(w) = \frac{1}{2\pi i} \int_{\gamma_R} \frac{f(z)}{z-w} dz - \frac{1}{2\pi i} \int_{\gamma_r} \frac{f(z)}{z-w} dz = \sum_{n \in \mathbb{Z}} c_n z^n,$$

as required. To see that the c_n are unique, one checks using uniform convergence that if $\sum_{n \in \mathbb{Z}} d_n z^n$ is any series expansion for $f(z)$ on A , then the d_n must be given by the integral formulae above.

Finally, to see that the c_n can be computed using any circular contour γ_s , note that if $r \leq s_1 < s_2 \leq R$ then $f/(z-z_0)^{n+1}$ is holomorphic in A hence by the Deformation Theorem 2.4.7 integrals are the same for all circular contours. \square

Remark 3.5.13. Note that the above proof shows that the integral $\int_{\gamma_R} \frac{f(z)}{z-w} dz$ defines a holomorphic function of w in $B(z_0, R)$, while $\int_{\gamma_r} \frac{f(z)}{z-w} dz$ defines a holomorphic function of w on $\mathbb{C} \setminus B(z_0, r)$. Thus we have actually expressed $f(w)$ on A as the difference of two functions which are holomorphic on $B(z_0, R)$ and $\mathbb{C} \setminus \bar{B}(z_0, r)$ respectively.

It is possible to push the previous theorem to the limit and apply it to a punctured disc.

Corollary 3.5.14 (Laurent series in a punctured disc). *If $f: U \rightarrow \mathbb{C}$ is a holomorphic function and z_0 is an isolated singularity, then f has a Laurent expansion on a punctured disc $B(z_0, R) \setminus \{z_0\}$ for any R such that $B(z_0, R) \setminus \{z_0\} \subset U$.*

⁸Note the sign change.

Proof. Let us take some r such that $0 < r < R$ and apply Theorem 3.5.9 to $A = A(z_0, r, R)$. Note that the coefficients c_n can be written in terms of integrals along γ_R , hence they do not depend on r . By sending r to zero we can see that the Laurent series converges in

$$B(z_0, R) = \bigcup_{0 < r < R} A(z_0, r, R)$$

and uniformly in $A(z_0, r, R')$ for any $0 < r < R' < R$. \square

Definition 3.5.15. Let z_0 be an isolated singularity of f and $\sum c_n(z - z_0)^n$ be its Laurent's expansion. Its *principal part* of f at z_0 is the sum of terms with negative powers and denoted $P_{z_0}f$. Namely,

$$P_{z_0}f(z) = \sum_{-\infty}^{-1} c_n(z - z_0)^n = \sum_1^{\infty} c_{-n}(z - z_0)^{-n}.$$

Proposition 3.5.16. *The principal part of f at z_0 converges on $\mathbb{C} \setminus \{z_0\}$ and converges uniformly on $\mathbb{C} \setminus B(z_0, r)$.*

Proof. This follows immediately from the proof of Theorem 3.5.9. In the proof we have used that if f is holomorphic on $A(z_0, r, R)$ then the principal part converges uniformly on $\{z : |z - z_0| > r'\}$ for any $r' > r$. Since in the case of isolated singularities we can take r to be arbitrarily small, the claim follows immediately. \square

Note that something very interesting happens with the term of order $n = -1$. Theorem 3.5.9 tells us that the coefficient

$$c_{-1} = \frac{1}{2\pi i} \int_{\gamma_s} f(z) dz.$$

This should not really be surprising. If we have a function f given by a series $\sum c_n(z - z_0)^n$ which converges uniformly in an annulus containing γ_s , then we can integrate it term by term. For all $n \neq -1$ the powers $(z - z_0)^n$ have a well defined primitive $(z - z_0)^{n+1}/(n+1)$ so they integrate to zero. But as we have discussed before the integral of $1/(z - z_0)$ along γ_s is $2\pi i$ so

$$\frac{1}{2\pi i} \int_{\gamma_s} f(z) dz = \frac{1}{2\pi i} \int_{\gamma_s} \sum c_n(z - z_0)^n = \frac{1}{2\pi i} \int_{\gamma_s} \frac{c_{-1}}{z - z_0} dz = c_{-1}.$$

This observation motivates the following definition.

Definition 3.5.17. Let z_0 be an isolated singularity of f . Then the *residue* of f at z_0 is defined as the coefficient c_{-1} of the Laurent expansion and denoted by $\text{Res}_{z_0} f$ or $\text{Res}(f, z_0)$.

Laurent's series allows us to characterize isolated singularities in terms of the series coefficients.

Theorem 3.5.18 (Characterization of isolated singularities). *Let z_0 be an isolated singularity of f . Let $\sum_{-\infty}^{\infty} c_n(z - z_0)^n$ be its Laurent expansion. Then z_0 is*

- *A removable singularity if $c_n = 0$ for all $n < 0$. Equivalently, the principal part vanishes.*
- *A pole of order n is $c_{-n} \neq 0$ and $c_k = 0$ for all $k < -n$. Equivalently, the principal part is non-trivial but contains only a finite number of non-zero terms.*
- *An essential singularity if there are arbitrary large n such that $c_{-n} \neq 0$. Equivalently, the principal part contains infinitely many non-zero terms.*

Remark 3.5.19. This is very similar to the characterization of a zero of multiplicity n . In this case we have a Taylor series $\sum_{n=0}^{\infty} a_k(z - z_0)^k$ with $a_k = 0$ for all $k < n$ and $a_n \neq 0$.

Remark 3.5.20. Some authors *define* types of singularities in terms of the Laurent expansion.

Proof. If there is no principal part, then we have an ordinary power series which converges to a function g which is analytic in some disc $B(z_0, R)$ around z_0 . Clearly, $f(z) - g(z) = 0$ for all $0 < |z - z_0| < R$, so z_0 is removable.

If z_0 is removable, then there is a function g which is holomorphic at z_0 and coincides with f in $B(z_0, R) \setminus \{z_0\}$. Hence their Laurent expansion coefficients are equal, but for a holomorphic function g all coefficients with negative n are given by integrals of a holomorphic function $(z - z_0)^{-n-1}g(z)$, but by Cauchy's theorem such integrals vanish.

If the Laurent expansion is of the form

$$f(z) = \frac{c_{-n}}{(z - z_0)^n} + \cdots + c_0 + c_1(z - z_0) + \cdots,$$

with $c_{-n} \neq 0$ then $f(z) = (z - z_0)^{-n}g(z)$ where

$$g(z) = c_{-n} + c_{-n+1}(z - z_0) + \cdots$$

which is analytic in some neighbourhood of z_0 .

If z_0 is a pole of order n , then there is a holomorphic g such that $g(z_0) \neq 0$ and $f(z) = (z - z_0)^{-n}g(z)$. Writing the Taylor series of g we see that the Laurent expansion of f is of the form

$$f(z) = \frac{g(z_0)}{(z - z_0)^n} + \frac{g'(z_0)}{(z - z_0)^{n-1}} \cdots$$

The last part follows trivially from the first two. \square

Finally, it is possible to characterize types of singularities by looking at the local behaviour of f near z_0 . We describe it in a series of three theorems.

Theorem 3.5.21 (Riemann's removable singularity theorem). *Suppose that U is an open subset of \mathbb{C} and $z_0 \in U$ and suppose that $f: U \setminus \{z_0\} \rightarrow \mathbb{C}$ is holomorphic. Then z_0 is a removable singularity if and only if f is bounded near z_0 .*

Proof. One direction is trivial. If z_0 is removable, then there is holomorphic g such that $g(z) = f(z)$ on $B(z_0, r) \setminus \{z_0\}$ for some $r > 0$. This proves that $f(z) = g(z) \rightarrow g(z_0)$ as $z \rightarrow z_0$. In particular, f is bounded.

Now, let us assume that f is bounded and define $h(z)$ by

$$h(z) = \begin{cases} (z - z_0)^2 f(z), & z \neq z_0; \\ 0, & z = z_0 \end{cases}$$

Then clearly $h(z)$ is holomorphic on $U \setminus \{z_0\}$, using the fact that f is and standard rules for complex differentiability. On the other hand, at $z = z_0$ we see directly that

$$\frac{h(z) - h(z_0)}{z - z_0} = (z - z_0)f(z) \rightarrow 0$$

as $z \rightarrow z_0$ since f is bounded near z_0 by assumption. It follows that h is in fact holomorphic everywhere in U . But then if we chose $r > 0$ is such that $\bar{B}(z_0, r) \subset U$, then by Corollary 3.3.2 $h(z)$ is equal to its Taylor series centred at z_0 , thus

$$h(z) = \sum_{k=0}^{\infty} a_k (z - z_0)^k.$$

But since we have $h(z_0) = h'(z_0) = 0$ we see $a_0 = a_1 = 0$, and hence $\sum_{k=0}^{\infty} a_{k+2} (z - z_0)^k$ defines a holomorphic function in $B(z_0, r)$. Since this clearly agrees with $f(z)$ on $B(z_0, r) \setminus \{0\}$, we see that by redefining $f(z_0) = a_2$, we can extend f to a holomorphic function on all of U as required. \square



Remark 3.5.22. This is yet another reminder that complex analysis is very different from the real one. The notions of isolated and removable singularities make sense in \mathbb{R} as well but there is nothing similar to Riemann's removable singularity theorem. Let us consider the following functions on $\mathbb{R} \setminus \{0\}$: $f(x) = \text{sign}(x)$, $g(x) = \sin(1/x)$ and $h(x) = |x|$. All of them are analytic outside of 0 and bounded in a neighbourhood of 0. Clearly, f has left and right limits but they are different, so there is no way to define $f(0)$ so that it becomes continuous. Function g oscillates near 0, so it does not have even one-sided limits. So the singularity is not removable. With h the situation is a bit different, h has a limit at 0 and it can be made into a continuous function, but it will not be differentiable. So again, the singularity is not removable. None of these scenarios is possible for complex functions.

Lemma 3.5.23. *Let f be a holomorphic function in a neighbourhood of z_0 . Then z_0 is a pole if and only if $|f(z)| \rightarrow \infty$ as $z \rightarrow z_0$. Moreover, in this case, the function*

$$h(z) = \begin{cases} 1/f(z), & z \neq z_0; \\ 0, & z = z_0 \end{cases}$$

is holomorphic in a neighbourhood of z_0 and the multiplicity of its zero at z_0 is equal to the order of the pole of f .

Proof. Let us assume that f has a pole of order n . Then by Theorem 3.5.18 it Laurent expansion is

$$f(z) = \frac{c_{-n}}{(z - z_0)^n} + \dots + c_0 + c_1(z - z_0) + \dots$$

This expansion can be rewritten as

$$\frac{1}{(z - z_0)^n} (c_{-n} + c_{-n+1}(z - z_0) + \dots).$$

The series converges to a function analytic at z_0 which we denote by g . Then $f^{-1} = (z - z_0)^n g^{-1}(z)$. Since $g(z_0) = c_{-n} \neq 0$ the function $h = 1/g$ is holomorphic in a neighbourhood of z_0 and $h(z_0) \neq 0$. This proves that $1/f$ has a removable singularity and after removing this singularity it has a zero of multiplicity n .

Let us assume that $|f| \rightarrow \infty$. Then the function $1/f \rightarrow 0$ and by Theorem 3.5.21 it extends to a holomorphic function h which has a zero at z_0 . We know that the zero must be of finite order, say $n \geq 1$, so $h(z) = (z - z_0)^n g(z)$ where g is holomorphic with $g(z_0) \neq 0$. Then $f(z) = (z - z_0)^{-n} g^{-1}(z)$, so by the definition f has a pole of order n . \square

Remark 3.5.24. Theorems 3.5.21 and 3.5.23 show that removable singularities and poles are not that dissimilar. In both cases, f converges as $z \rightarrow z_0$ in one case to a finite limit in the other to infinity. By considering the extended complex plane \mathbb{C}_∞ (also known as the Riemann sphere) the distinction completely disappears, in both cases f can be extended to a holomorphic \mathbb{C}_∞ -valued function.

At this stage, one might guess that the essential singularity covers all other types of behaviour near z_0 . But we already know that this is not quite the case, for example, Theorem 3.5.21 shows that f can not stay bounded without having a limit. The following theorem shows that the behaviour near an essential singularity is quite peculiar: it must oscillate in the worst imaginable way. This is yet another example showing the difference between real and complex analysis. In complex analysis, function either has a limit or fails to have a limit in the most spectacular way.



Theorem 3.5.25 (Casorati-Weierstrass or Weierstrass Theorem). *Let U be an open subset of \mathbb{C} and let $a \in U$. Suppose that $f: U \setminus \{a\} \rightarrow \mathbb{C}$ is a holomorphic function with an isolated essential singularity at a . Then for all $\rho > 0$ with $B(a, \rho) \subseteq U$, the set $f(B(a, \rho) \setminus \{a\})$ is dense in \mathbb{C} , that is, the closure of $f(B(a, \rho) \setminus \{a\})$ is all of \mathbb{C} .*

Proof. Suppose, for the sake of a contradiction, that there is some $\rho > 0$ such that $z_0 \in \mathbb{C}$ is not a limit point of $f(B(a, \rho) \setminus \{a\})$. Then the function $g(z) = 1/(f(z) - z_0)$ is bounded and non-vanishing on $B(a, \rho) \setminus \{a\}$, and hence by Riemann's removable singularity theorem, it extends to a holomorphic function on all of $B(a, \rho)$. But then $f(z) = z_0 + 1/g(z)$ has at most a pole at a which is a contradiction. \square

Remark 3.5.26. In fact, much more is true: Picard showed that if f has an isolated essential singularity at z_0 then in any open disk about z_0 the function f takes every complex value infinitely often with at most one exception. The example of the function $f(z) = \exp(1/z)$, which has an essential singularity at $z = 0$ shows that this result is best possible, since $f(z) \neq 0$ for all $z \neq 0$.

We finish this section with the following theorem which by now is almost a trivial corollary of other results. On the other hand, this theorem is very useful for many applications.

Theorem 3.5.27 (Residue theorem). *Suppose that U is an open set in \mathbb{C} and γ is a closed curve that is contained in U together with its inside. Suppose that f is holomorphic on $U \setminus S$ where S is a finite set of isolated*

singularities of f . We also assume that f has no singularities on γ^* , that is $S \cap \gamma^* = \emptyset$. Then

$$\frac{1}{2\pi i} \int_{\gamma} f(z) dz = \sum_{a \in S} I(\gamma, a) \operatorname{Res}_a(f)$$

Proof. For each $a \in S$ let $P_a(f)(z) = \sum_{n=-1}^{-\infty} c_n(a)(z-a)^n$ be the principal part of f at a , a holomorphic function on $\mathbb{C} \setminus \{a\}$. Then by definition of $P_a(f)$, the difference $f - P_a(f)$ is holomorphic⁹ at $a \in S$, and thus $g(z) = f(z) - \sum_{a \in S} P_a(f)$ is holomorphic on all of U . But then by Theorem 2.4.7 we see that $\int_{\gamma} g(z) dz = 0$, so that

$$\int_{\gamma} f(z) dz = \sum_{a \in S} \int_{\gamma} P_a(f)(z) dz.$$

Note that to apply the Homotopy Cauchy Theorem we use the fact that if U contains γ and its inside then γ is null-homotopic.

By Proposition 3.5.16 the series $P_a(f)$ converges uniformly on γ^* so that

$$\begin{aligned} \int_{\gamma} P_a(f) dz &= \int_{\gamma} \sum_{n=-1}^{-\infty} c_n(a)(z-a)^n = \sum_{n=1}^{\infty} \int_{\gamma} \frac{c_{-n}(a) dz}{(z-a)^n} \\ &= \int_{\gamma} \frac{c_{-1}(a) dz}{z-a} = 2\pi i I(\gamma, a) \operatorname{Res}_a(f), \end{aligned}$$

since for $n > 1$ the function $(z-a)^{-n}$ has a primitive on $\mathbb{C} \setminus \{a\}$. The result follows. □

Remark 3.5.28. In practice, in applications of the residue theorem, the winding numbers $I(\gamma, a)$ will be simple to compute in terms of the argument of $(z-a)$ – in fact most often they will be 0 or ± 1 as we will usually apply the theorem to integrals around simple closed curves.

3.6 The argument principle

Lemma 3.6.1. *Suppose that $f: U \rightarrow \mathbb{C}$ is meromorphic and has a zero of order k or a pole of order k at $z_0 \in U$. Then $f'(z)/f(z)$ has a simple pole at z_0 with residue k or $-k$ respectively.*

⁹This is a slight abuse of notations since strictly speaking f is not defined at a , so $f - P_a f$ is not even defined at a . On the other hand, it has a removable singularity there, so we should remove this singularity and use the extended function instead.



Proof. If $f(z)$ has a zero of order k we have $f(z) = (z - z_0)^k g(z)$ where $g(z)$ is holomorphic near z_0 and $g(z_0) \neq 0$. It follows that

$$\frac{f'(z)}{f(z)} = \frac{k}{z - z_0} + \frac{g'(z)}{g(z)},$$

and since $g(z) \neq 0$ near z_0 it follows $g'(z)/g(z)$ is holomorphic near z_0 , so that the result follows. The case where f has a pole at z_0 is similar. \square

Theorem 3.6.2. (*Argument principle*): Suppose that f is meromorphic on U and γ be a simple positively oriented contour such that the contour and its inside are contained in U . We assume that f has no zeroes or poles on γ^* . If N is the number of zeros (counted with multiplicity) and P is the number of poles (again counted with multiplicity) of f inside γ then

$$N - P = \frac{1}{2\pi i} \int_{\gamma} \frac{f'(z)}{f(z)} dz.$$

Moreover, this is the winding number of the path $\Gamma = f \circ \gamma$ about the origin.

Proof. The curve is simple, so its winding number around any point inside is equal to 1. Lemma 3.6.1 shows that $f'(z)/f(z)$ has simple poles at the zeros and poles of f with residues given by their orders. So the result follows immediately from the Residue Theorem 3.5.27.

For the last part, note that the winding number of $\Gamma(t) = f(\gamma(t))$ about zero is just

$$\int_{f \circ \gamma} \frac{1}{w} dw = \int_0^1 \frac{1}{f(\gamma(t))} f'(\gamma(t)) \gamma'(t) dt = \int_{\gamma} \frac{f'(z)}{f(z)} dz.$$

\square

The argument principle is very useful – we use it here to establish some important results.

Theorem 3.6.3 (Rouché). Suppose that f and g are holomorphic functions on an open set U in \mathbb{C} and γ be a simple contour that is contained inside of U together with its interior. If $|f(z)| > |g(z)|$ for all $z \in \gamma^*$ then f and $f + g$ have the same change in argument around γ , and hence the same number of zeros (counted with multiplicities) inside of γ .

Proof. Consider the function $h = (f + g)/f = 1 + g/f$. Its zeros are zeros of $f + g$ and its poles are zeros of f . We need to show that h has the

same total number of zeros as poles inside of γ . Note that the assumption $|f(z)| > |g(z)|$ implies that h has no zeroes or poles on γ^* . But by the argument principle, the difference between the number of zeroes and poles is equal to the winding number of $\Gamma(t) = h(\gamma(t))$ about zero. Since, by assumption, for $z \in \gamma^*$ we have $|g(z)| < |f(z)|$ and so $|g(z)/f(z)| < 1$, the image of Γ lies entirely in $B(1, 1)$ and thus in the half-plane $\{z : \operatorname{Re}(z) > 0\}$. Hence picking the principal branch of $[\log]$ defined on this half-plane, we see that the integral

$$\int_{\Gamma} \frac{dz}{z} = \operatorname{Log}(h(\gamma(1))) - \operatorname{Log}(h(\gamma(0))) = 0$$

as required. □

Remark 3.6.4. Rouché's theorem can be useful in counting the number of zeros of a function f – one tries to find an approximation to f whose zeros are easier to count and then by Rouché's theorem obtain information about the zeros of f . Just as for the argument principle above, it also holds for closed paths which having winding number 1 about their inside.

Example 3.6.5. Suppose that $P(z) = z^4 + 5z + 2$. Then on the circle $|z| = 2$, we have $|z|^4 = 16 > 5 \cdot 2 + 2 \geq |5z + 2|$, so that if $g(z) = 5z + 2$ we see that $P - g = z^4$ and P have the same number of roots in $B(0, 2)$. It follows by Rouché's theorem that the four roots of $P(z)$ all have a modulus less than 2. On the other hand, if we take $|z| = 1$, then $|5z + 2| \geq 5 - 2 = 3 > |z^4| = 1$, hence $P(z)$ and $5z + 2$ have the same number of roots in $B(0, 1)$. It follows $P(z)$ has one root of modulus less than 1, and 3 of modulus between 1 and 2.

Theorem 3.6.6 (Open mapping theorem). *Suppose that $f: U \rightarrow \mathbb{C}$ is holomorphic and non-constant on a domain U . Then for any open set $V \subset U$ the set $f(V)$ is also open.*

Proof. Suppose that $w_0 \in f(V)$ and consider some z_0 such that $f(z_0) = w_0$. The function $g(z) = f(z) - w_0$ has a zero at z_0 . Since g is non-constant, this zero is isolated. Thus we may find an $r > 0$ such that $g(z)$ has no other zeros inside $\bar{B}(z_0, r) \subset U$. In particular, since $\partial B(z_0, r)$ is compact, we have that there is a positive δ such that $|g(z)| \geq \delta > 0$ on $\partial B(z_0, r)$. Consider any w such that $|w - w_0| < \delta$. Then $|w - w_0| < \delta \leq |g|$ on $\partial B(z_0, r)$. Hence, by Rouché's theorem, $g(z)$ and $g(z) + w_0 - w = f(z) - w$ have the same number of zeros (counting multiplicities) inside $B(z_0, r)$. Since $g(z)$ has a

zero at z_0 of multiplicity at least one, the equation $f = w$ also has at least one solutions inside $B(z_0, r)$. Thus $B(w_0, \delta) \subseteq f(B(z_0, r))$ and $f(U)$ is open as required. \square

Remark 3.6.7. Note that the proof actually establishes a bit more than the statement of the theorem: if $w_0 = f(z_0)$ then the multiplicity d of the zero of the function $f(z) - w_0$ at z_0 is called the *degree* of f at z_0 . The proof shows that locally the function f is d -to-1, counting multiplicities, that is, there are $r, \epsilon \in \mathbb{R}_{>0}$ such that for every $w \in B(w_0, \epsilon)$ the equation $f(z) = w$ has d solutions counted with multiplicity in the disk $B(z_0, r)$. In particular, if $f'(z_0) \neq 0$ then the degree is 1 and the function is locally 1-to-1.

Theorem 3.6.8 (Inverse function theorem). *Suppose that $f: U \rightarrow \mathbb{C}$ is injective and holomorphic and that $f'(z) \neq 0$ for all $z \in U$. If $g: f(U) \rightarrow U$ is the inverse of f , then g is holomorphic with $g'(w) = 1/f'(g(w))$.*

Proof. By the open mapping theorem, the function g is continuous, indeed if V is open in $f(U)$ then $g^{-1}(V) = f(V)$ is open by that theorem. To see that g is holomorphic, fix $w_0 \in f(U)$ and let $z_0 = g(w_0)$. Note that since g and f are continuous, if $w \rightarrow w_0$ then $z = g(w) \rightarrow z_0$ and we have

$$\lim_{w \rightarrow w_0} \frac{g(w) - g(w_0)}{w - w_0} = \lim_{z \rightarrow z_0} \frac{z - z_0}{f(z) - f(z_0)} = \frac{1}{f'(z_0)}$$

as required. \square

Remark 3.6.9. Note that the non-trivial part of the proof of the above theorem is the fact that g is continuous! In fact the condition that $f'(z) \neq 0$ follows from the fact that f is bijective – this can be seen using the degree of f : if $f'(z_0) = 0$ and f is non-constant, we must have $f(z) - f(z_0) = (z - z_0)^k g(z)$ where $g(z_0) \neq 0$ and $k \geq 1$. Since we can choose a holomorphic branch of $g^{1/k}$ near z_0 it follows that $f(z)$ is locally k -to-1 near z_0 , which contradicts the injectivity of f . For details see the Appendices. Notice that this is in contrast with the case of a single real variable, as the example $f(x) = x^3$ shows. Once again, complex analysis is “nicer” than real analysis!



3.7 Applications of the Residue theorem

Let us recall that if γ is a simple positively oriented contour and f is holomorphic on and inside of γ except at a finite set S of isolated singularities

none of which lies on γ^* itself. Then

$$\int_{\gamma} f(z) dz = 2\pi i \sum_{z_0 \in S} \operatorname{Res}_{z_0}(f).$$

In this section, we will discuss how to use this formula to compute various integrals.

3.7.1 On the computation of residues

A lot will depend on our ability to compute residues. For example, in the case of poles, we can use the following result.

Lemma 3.7.1. *Suppose that f has a pole of order m at z_0 , then*

$$\operatorname{Res}_{z_0}(f) = \lim_{z \rightarrow z_0} \frac{1}{(m-1)!} \frac{d^{m-1}}{dz^{m-1}} ((z-z_0)^m f(z))$$

Proof. Since f has a pole of order m at z_0 we have $f(z) = \sum_{n \geq -m} c_n (z-z_0)^n$ for z sufficiently close to z_0 . Thus

$$(z-z_0)^m f(z) = c_{-m} + c_{-m+1}(z-z_0) + \dots + c_{-1}(z-z_0)^{m-1} + \dots$$

and the result follows from the formula for the derivatives of a power series. \square

Remark 3.7.2. The last lemma is perhaps most useful in the case where the pole is simple since in that case no derivatives need to be computed. In fact, there is a special case which is worth emphasizing: Suppose that $f = g/h$ is a ratio of two holomorphic functions defined on a domain $U \subseteq \mathbb{C}$, where h is non-constant. Then f is meromorphic with poles at the zeros¹⁰ of h . In particular, if h has a simple zero at z_0 and g is non-vanishing there, then f correspondingly has a simple pole at z_0 . Since the zero of h is simple at z_0 , we must have $h'(z_0) \neq 0$, and hence by the previous result

$$\operatorname{Res}_{z_0}(f) = \lim_{z \rightarrow z_0} \frac{g(z)(z-z_0)}{h(z)} = \lim_{z \rightarrow z_0} g(z) \lim_{z \rightarrow z_0} \frac{z-z_0}{h(z)-h(z_0)} = g(z_0)/h'(z_0)$$

where the last equality holds by standard Algebra of Limits results.

¹⁰Strictly speaking, the poles of f form a subset of the zeros of h , since if g also vanishes at a point z_0 , then f may have a removable singularity at z_0 .

Example 3.7.3. Let $f(z) = \exp(z)/\sin(z)$. Since \sin has simple zeros at points $z_k = \pi k$, the function f has simple poles at z_k . By the formula above

$$\operatorname{Res}_{z_k} f = \lim_{z \rightarrow z_k} \frac{(z - z_k) \exp(z)}{\sin(z)} = \frac{\exp(z_k)}{\sin'(z_k)} = \frac{\exp(z_k)}{\cos(z_k)}.$$

If the pole is of the higher order such computations become much more involved.

Example 3.7.4. Consider $f(z) = \sin^{-2}(z)$ and a pole of order 2 at $z_0 = 0$. Then the Lemma 3.7.1 gives us

$$\operatorname{Res}_0 f = \lim_{z \rightarrow 0} \frac{d}{dz} \left(\frac{z}{\sin(z)} \right)^2 = \lim_{z \rightarrow 0} 2 \frac{z}{\sin(z)} \frac{\sin(z) - z \cos(z)}{\sin^2(z)} = 0.$$

Note that even for such a simple function and for a pole of a small order, the computation of the limit is non-trivial, since we have to argue that $\sin(z) - z \cos(z) = o(z^2)$. The easiest way of doing this is to consider the Taylor series of \sin and \cos .

In many cases it is easier to compute residues or even the entire principal part by analysing power series without referring to Lemma 3.7.1. A typical computation is below:

Example 3.7.5. Consider the same function $f = 1/\sin^2$ and $z_0 = 0$. Then we can write

$$f(z) = \frac{1}{(z - z^3/6 + \dots)^2} = \frac{1}{z^2(1 - z^2/6 + \dots)^2} = \frac{1}{z^2} \frac{1}{(1 - z^2/3 + \dots)}.$$

Let us denote $g(z) = z^2/3 + \dots$. This is an analytic function with $g(0) = 0$. This means that if $|z|$ is sufficiently small then $|g| < 1/2$ so

$$\frac{1}{1 - g(z)} = 1 + g(z) + g^2(z) + \dots = 1 + \frac{z^2}{3} + \dots$$

Combining all of this we get

$$f(z) = \frac{1}{z^2} + \frac{1}{3} + \dots$$

Hence the principal part is $1/z^2$ and $\operatorname{Res}_0 f = 0$.

Example 3.7.6. Consider $f(z) = 1/(z^2 \sinh(z)^3)$. Now $\sinh(z) = (e^z - e^{-z})/2$ vanishes on $\pi i \mathbb{Z}$, and these zeros are all simple since $\frac{d}{dz}(\sinh(z)) = \cosh(z)$ has $\cosh(n\pi i) = (-1)^n \neq 0$. Thus $f(z)$ has a pole of order 5 at

zero, and poles of order 3 at πin for each $n \in \mathbb{Z} \setminus \{0\}$. Let us calculate the principal part of f at $z = 0$ using the same technique. We will write $O(z^k)$ for any holomorphic functions which vanish to order k at 0.

$$\begin{aligned} z^2 \sinh(z)^3 &= z^2 \left(z + \frac{z^3}{3!} + \frac{z^5}{5!} + O(z^7) \right)^3 = z^5 \left(1 + \frac{z^2}{3!} + \frac{z^4}{5!} + O(z^6) \right)^3 \\ &= z^5 \left(1 + \frac{3z^2}{3!} + \frac{3z^4}{(3!)^2} + \frac{3z^4}{5!} + O(z^6) \right) \\ &= z^5 \left(1 + \frac{z^2}{2} + \frac{13z^4}{120} + O(z^6) \right) \end{aligned}$$

As before, we introduce

$$g(z) = \frac{z^2}{2} + \frac{13z^4}{120} + O(z^5) = z^2 \left(\frac{1}{2} + \frac{13z^2}{120} + O(z^3) \right)$$

Using the geometric series we get

$$\begin{aligned} \frac{1}{1+g(z)} &= 1 - g(z) + g^2(z) + \dots \\ &= 1 - z^2 \left(\frac{1}{2} + \frac{13z^2}{120} + O(z^3) \right) + z^4 \left(\frac{1}{2} + \frac{13z^2}{120} + O(z^3) \right)^2 + O(z^6) \\ &= 1 - \frac{z^2}{2} + \left(\frac{1}{4} - \frac{13}{120} \right) z^4 + O(z^5) = 1 - \frac{z^2}{2} + \frac{17z^4}{120} + O(z^5). \end{aligned}$$

Combining all expansions we get

$$\frac{1}{z^2 \sinh(z)^3} = \frac{1}{z^5} \frac{1}{1+g(z)} = \frac{1}{z^5} - \frac{1}{2z^3} + \frac{17}{120z} + O(1).$$

This gives the entire principal part and in particular $\text{Res}_0(f) = 17/120$.

There are other variants of the above method which we could have used: For example, by the binomial theorem for an arbitrary exponent we know that if $|z| < 1$ then $(1+z)^{-3} = \sum_{n \geq 0} \binom{-3}{n} z^n = 1 - 3z + 6z^2 + \dots$. Arguing as above, it follows that for small enough z we have

$$\begin{aligned} \sinh(z)^{-3} &= z^{-3} \cdot \left(1 + \frac{z^2}{3!} + \frac{z^4}{5!} + O(z^6) \right)^{-3} \\ &= z^{-3} \left(1 + (-3) \left(\frac{z^2}{3!} + \frac{z^4}{5!} \right) + 6 \left(\frac{z^2}{3!} + \frac{z^4}{5!} \right)^2 + O(z^6) \right) \\ &= z^{-3} \left(1 - \frac{z^2}{2} + \left(\frac{-3}{5!} + \frac{6}{(3!)^2} \right) z^4 + O(z^6) \right) \\ &= z^{-3} \left(1 - \frac{z^2}{2} + \frac{17z^4}{120} + O(z^6) \right) \end{aligned}$$

yielding the same result for the principal part of $1/z^2 \sinh(z)^3$.

3.7.2 Residue Calculus

As mentioned before, the Residue theorem gives us a very powerful technique for computing many kinds of integrals. In this section, we give a number of examples of its application.

Example 3.7.7. Consider the integral

$$\int_0^{2\pi} \frac{dt}{1 + 3 \cos^2(t)}.$$

If we let γ be the path $t \mapsto e^{it}$ and let $z = e^{it}$ then $\cos(t) = \operatorname{Re}(z) = \frac{1}{2}(z + \bar{z}) = \frac{1}{2}(z + 1/z)$. Thus we have

$$\frac{1}{1 + 3 \cos^2(t)} = \frac{1}{1 + 3/4(z + 1/z)^2} = \frac{1}{1 + \frac{3}{4}z^2 + \frac{3}{2} + \frac{3}{4}z^{-2}} = \frac{4z^2}{3 + 10z^2 + 3z^4},$$

Finally, since $dz = izdt$ it follows

$$\int_0^{2\pi} \frac{dt}{1 + 3 \cos^2(t)} = \int_{\gamma} \frac{-4iz}{3 + 10z^2 + 3z^4} dz.$$

Thus we have turned our real integral into a contour integral, and to evaluate the contour integral we just need to calculate the residues of the meromorphic function $g(z) = \frac{-4iz}{3 + 10z^2 + 3z^4}$ at the poles it has inside the unit circle. Now the poles of $g(z)$ are the zeros of the polynomial $p(z) = 3 + 10z^2 + 3z^4$, which are at $z^2 \in \{-3, -1/3\}$. Thus the poles inside the unit circle are at $\pm i/\sqrt{3}$. In particular, since p has degree 4 and has four roots, they must all be simple zeros, and so g has simple poles at these points. The residue at a simple pole z_0 can be calculated as the limit $\lim_{z \rightarrow z_0} (z - z_0)g(z)$, thus we see (compare with Remark 3.7.2) that

$$\begin{aligned} \operatorname{Res}_{z=\pm i/\sqrt{3}}(g(z)) &= \lim_{z \rightarrow \pm i/\sqrt{3}} \frac{-4iz(z - \pm i/\sqrt{3})}{3 + 10z^2 + 3z^4} = (\pm 4/\sqrt{3}) \frac{1}{p'(\pm i/\sqrt{3})} \\ &= (\pm 4/\sqrt{3}) \frac{1}{20(\pm i/\sqrt{3}) + 12(\pm i/\sqrt{3})^3} = 1/4i. \end{aligned}$$

It now follows from the Residue theorem that

$$\int_0^{2\pi} \frac{dt}{1 + 3 \cos^2(t)} = 2\pi i (\operatorname{Res}_{z=i/\sqrt{3}}(g(z)) + \operatorname{Res}_{z=-i/\sqrt{3}}(g(z))) = \pi.$$

Remark 3.7.8. We can similarly write $\sin(t) = (z - 1/z)/(2i)$ and express all other trigonometric functions in terms of rational functions of z . Thus many trigonometric integrals can be turned into integrals of rational functions. All such integrals can be computed quite easily as long as one can find all singularities.

Often we are interested in integrating along a path which is not closed or even finite, for example, we might wish to understand the integral of a function on the positive real axis. The residue theorem can still be a powerful tool in calculating these integrals, provided we complete the path to a closed one in such a way that we can control the extra contribution to the integral along the part of the path we add.

Example 3.7.9. If we have a function f which we wish to integrate over the whole real line (so we have to treat it as an improper Riemann integral) then we may consider the contours Γ_R given as the concatenation of the paths $\gamma_1: [-R, R] \rightarrow \mathbb{C}$ and $\gamma_2: [0, 1] \rightarrow \mathbb{C}$ where

$$\gamma_1(t) = -R + t; \quad \gamma_2(t) = Re^{i\pi t}.$$

(so that $\Gamma_R = \gamma_2 \star \gamma_1$ traces out the boundary of a half-disk). In many cases one can show that $\int_{\gamma_2} f(z)dz$ tends to 0 as $R \rightarrow \infty$, and by calculating the residues inside the contours Γ_R deduce the integral of f on $(-\infty, \infty)$. To see this strategy in action, consider the integral

$$\int_0^\infty \frac{dx}{1 + x^2 + x^4}.$$

It is easy to check that this integral exists as an improper Riemann integral, and since the integrand is even, it is equal to

$$\frac{1}{2} \lim_{R \rightarrow \infty} \int_{-R}^R \frac{dx}{1 + x^2 + x^4}.$$

If $f(z) = 1/(1 + z^2 + z^4)$, then $\int_{\Gamma_R} f(z)dz$ is equal to $2\pi i$ times the sum of the residues inside the path Γ_R . The function $f(z) = 1/(1 + z^2 + z^4)$ has poles at $z^2 = \pm e^{2\pi i/3}$ and hence at $\{e^{\pi i/3}, e^{2\pi i/3}, e^{4\pi i/3}, e^{5\pi i/3}\}$. They are all simple poles and of these only $\{\omega, \omega^2\}$ are in the upper-half plane, where $\omega = e^{i\pi/3}$. Thus by the residue theorem, for all $R > 1$ we have

$$\int_{\Gamma_R} f(z)dz = 2\pi i (\text{Res}_\omega(f(z)) + \text{Res}_{\omega^2}(f(z))),$$

and we may calculate the residues using the limit formula as above (and the fact that it evaluates to the reciprocal of the derivative of $1+z^2+z^4$): Indeed since $\omega^3 = -1$ we have $\text{Res}_\omega(f(z)) = \frac{1}{2\omega+4\omega^3} = \frac{1}{2\omega-4}$, while $\text{Res}_{\omega^2}(f(z)) = \frac{1}{2\omega^2+4\omega^6} = \frac{1}{4+2\omega^2}$. Thus we obtain:

$$\begin{aligned} \int_{\Gamma_R} f(z)dz &= 2\pi i \left(\frac{1}{2\omega-4} + \frac{1}{2\omega^2+4} \right) \\ &= \pi i \left(\frac{1}{\omega-2} + \frac{1}{\omega^2+2} \right) \\ &= \pi i \left(\frac{\omega^2+\omega}{2(\omega-\omega^2)-5} \right) = -\frac{\sqrt{3}\pi}{-3} = \frac{\pi}{\sqrt{3}}, \end{aligned}$$

(where we used the fact that $\omega^2 + \omega = i\sqrt{3}$ and $\omega - \omega^2 = 1$). Now clearly

$$\int_{\Gamma_R} f(z)dz = \int_{-R}^R \frac{dt}{1+t^2+t^4} + \int_{\gamma_2} f(z)dz,$$

and by the estimation lemma we have

$$\left| \int_{\gamma_2} f(z)dz \right| \leq \sup_{z \in \gamma_2^*} |f(z)| \ell(\gamma_2) \leq \frac{\pi R}{R^4 - R^2 - 1} \rightarrow 0,$$

as $R \rightarrow \infty$, it follows that

$$\frac{\pi}{\sqrt{3}} = \lim_{R \rightarrow \infty} \int_{\Gamma_R} f(z)dz = \int_{-\infty}^{\infty} \frac{dt}{1+t^2+t^4}.$$

3.7.3 Jordan's Lemma and applications

The following lemma is a basic fact on *convexity*. Note that if x, y are vectors in any vector space then the set $\{tx + (1-t)y : t \in [0, 1]\}$ describes the line segment between x and y .

Lemma 3.7.10. *Let $g: \mathbb{R} \rightarrow \mathbb{R}$ be a twice differentiable function. Then if $[a, b]$ is an interval on which $g''(x) < 0$, the function g is concave on $[a, b]$, that is, for $x < y \in [a, b]$ we have*

$$g(tx + (1-t)y) \geq tg(x) + (1-t)g(y), \quad t \in [0, 1].$$

Thus informally speaking, chords between points on the graph of g lie below the graph itself.

Proof. Given $x, y \in [a, b]$ and $t \in [0, 1]$ let $\xi = tx + (1 - t)y$, a point in the interval between x and y . Now the slope of the chord between $(x, g(x))$ and $(\xi, g(\xi))$ is, by the Mean Value Theorem, equal to $g'(s_1)$ where s_1 lies between x and ξ , while the slope of the chord between $(\xi, g(\xi))$ and $(y, g(y))$ is equal to $g'(s_2)$ for s_2 between ξ and y . If $g(\xi) < tg(x) + (1 - t)g(y)$ it follows that $g'(s_1) < 0$ and $g'(s_2) > 0$. Thus by the mean value theorem for $g'(x)$ applied to the points s_1 and s_2 it follows there is an $s \in (s_1, s_2)$ with $g''(s) = (g'(s_2) - g'(s_1))/(s_2 - s_1) > 0$, contradicting the assumption that $g''(x)$ is negative on (a, b) . \square

The following lemma is an easy application of this convexity result.

Lemma 3.7.11 (Jordan's Lemma). *Let f be a continuous function on γ_R^* where $\gamma_R(t) = Re^{it}$ where $t \in [0, \pi]$. Then for all positive α*

$$\left| \int_{\gamma_R} f(z)e^{i\alpha z} dz \right| \leq \frac{\pi}{\alpha} M_R, \quad M_R = \max_{t \in [0, \pi]} |f(Re^{it})|.$$

In particular, suppose that f is holomorphic on $\mathbb{H} \setminus S$ where $\mathbb{H} = \{z \in \mathbb{C} : \text{Im}(z) > 0\}$ is the upper half-plane and S is a finite set of isolated singularities. Suppose that $f(z) \rightarrow 0$ as $z \rightarrow \infty$ in \mathbb{H} . Then

$$\int_{\gamma_R} f(z)e^{i\alpha z} dz \rightarrow 0$$

as $R \rightarrow \infty$ for all $\alpha > 0$.

Proof. Applying Lemma 3.7.10 to the function $g(t) = \sin(t)$ with $x = 0$ and $y = \pi/2$ we see that $\sin(t) \geq \frac{2}{\pi}t$ for $t \in [0, \pi/2]$. Similarly we have $\sin(\pi - t) \geq 2(\pi - t)/\pi$ for $t \in [\pi/2, \pi]$. Thus we have

$$|e^{i\alpha z}| \leq e^{-\alpha R \sin(t)} \leq \begin{cases} e^{-2\alpha R t/\pi} & t \in [0, \pi/2], \\ e^{-2\alpha R(\pi-t)/\pi} & t \in [\pi/2, \pi]. \end{cases}$$

But then it follows that

$$\left| \int_{\gamma_R} f(z)e^{i\alpha z} dz \right| \leq 2RM_R \int_0^{\pi/2} e^{-2\alpha R t/\pi} dt = M_R \frac{\pi}{\alpha} (1 - e^{-\alpha R}) < M_R \frac{\pi}{\alpha}.$$

This proves the first claim.

Next, fix some $\epsilon > 0$. Since $f \rightarrow 0$ as $z \rightarrow \infty$ and S is finite, there is R_0 such that $M_R < \epsilon$ for all $R > R_0$. This immediately implies that

$$\left| \int_{\gamma_R} f(z)e^{i\alpha z} dz \right| \leq \epsilon \frac{\pi}{\alpha}, \quad R > R_0.$$

Since ϵ is arbitrary, this proves the second claim. \square

Remark 3.7.12. If η_R is an arc of a semicircle in the upper half plane, say $\eta_R(t) = Re^{it}$ for $0 \leq t \leq 2\pi/3$, then the same proof shows that

$$\int_{\eta_R} f(z)e^{i\alpha z} dz \rightarrow 0 \quad \text{as } R \rightarrow \infty.$$

This is sometimes useful when integrating around the boundary of a sector of the disk (that is a set of the form $\{re^{i\theta} : 0 \leq r \leq R, \theta \in [\theta_1, \theta_2]\}$).

It is also useful to note that if $\alpha < 0$ then the integral of $f(z)e^{i\alpha z}$ around a semicircle in the *lower* half plane tends to zero as the radius of the semicircle tends to infinity provided $|f(z)| \rightarrow 0$ as $|z| \rightarrow \infty$ in the lower half plane. This follows immediately from the above applied to $f(-z)$.

Example 3.7.13. Consider the integral $\int_{-\infty}^{\infty} \frac{\sin(x)}{x} dx$. This is an improper integral of an even function, thus it exists if and only if the limit of $\int_{-R}^R \frac{\sin(x)}{x} dx$ exists as $R \rightarrow \infty$. To compute this consider the integral along the closed curve η_R given by the concatenation $\eta_R = \nu_R \star \gamma_R$, where $\nu_R: [-R, R] \rightarrow \mathbb{R}$ given by $\nu_R(t) = t$ and $\gamma_R(t) = Re^{it}$ (where $t \in [0, \pi]$). Now if we let $f(z) = \frac{e^{iz}-1}{z}$, then f has a removable singularity at $z = 0$ (as is easily seen by considering the power series expansion of e^{iz}) and so is an entire function. Thus we have $\int_{\eta_R} f(z) dz = 0$ for all $R > 0$. Thus we have

$$0 = \int_{\eta_R} f(z) dz = \int_{-R}^R f(t) dt + \int_{\gamma_R} \frac{e^{iz}}{z} dz - \int_{\gamma_R} \frac{dz}{z}.$$

Now Jordan's lemma ensures that the second term on the right tends to zero as $R \rightarrow \infty$, while the third term integrates to $\int_0^\pi \frac{iRe^{it}}{Re^{it}} dt = i\pi$. It follows that $\int_{-R}^R f(t) dt$ tends to $i\pi$ as $R \rightarrow \infty$. and hence taking imaginary parts we conclude the improper integral $\int_{-\infty}^{\infty} \frac{\sin(x)}{x} dx$ is equal to π .

Remark 3.7.14. The function $f(z) = \frac{e^{iz}-1}{z}$ might not have been the first meromorphic function one could have thought of when presented with the previous improper integral. A more natural candidate might have been $g(z) = \frac{e^{iz}}{z}$. There is an obvious problem with this choice, however, which is that it has a pole on the contour we wish to integrate around. In the case where the pole is simple (as it is for e^{iz}/z) there is a standard procedure for modifying the contour: one indents it by a small circular arc around the pole. Explicitly, we replace the ν_R with $\nu_R^- \star \gamma_\epsilon \star \nu_R^+$ where $\nu_R^\pm(t) = t$ and $t \in [-R, -\epsilon]$ for ν_R^- , and $t \in [\epsilon, R]$ for ν_R^+ (and as above $\gamma_\epsilon(t) = \epsilon e^{i(\pi-t)}$ for $t \in [0, \pi]$). Since $\frac{\sin(x)}{x}$ is bounded at $x = 0$ the sum

$$\int_{-R}^{-\epsilon} \frac{\sin(x)}{x} dx + \int_{\epsilon}^R \frac{\sin(x)}{x} dx \rightarrow \int_{-R}^R \frac{\sin(x)}{x} dx,$$

as $\epsilon \rightarrow 0$, while the integral along γ_ϵ can be computed explicitly: by the Taylor expansion of e^{iz} we see that $\text{Res}_{z=0} \frac{e^{iz}}{z} = 1$, so that $e^{iz} - 1/z$ is bounded near 0. It follows that as $\epsilon \rightarrow 0$ we have $\int_{\gamma_\epsilon} (e^{iz}/z - 1/z) dz \rightarrow 0$. On the other hand

$$\int_{\gamma_\epsilon} \frac{dz}{z} = \epsilon \int_0^\pi \frac{-\epsilon i e^{i(\pi-t)}}{\epsilon e^{i(\pi-t)}} dt = -i\pi,$$

so that we see

$$\int_{\gamma_\epsilon} \frac{e^{iz}}{z} dz \rightarrow -i\pi, \quad \epsilon \rightarrow 0.$$

Combining all of this we conclude that if $\Gamma_\epsilon = \nu_R^- \star \gamma_\epsilon \star \nu_R^+ \star \gamma_R$ then

$$\begin{aligned} 0 &= \int_{\Gamma_\epsilon} f(z) dz = \int_{-R}^{-\epsilon} \frac{e^{ix}}{x} dx + \int_{\gamma_\epsilon} \frac{e^{iz}}{z} dz + \int_\epsilon^R \frac{e^{ix}}{x} dx + \int_{\gamma_R} \frac{e^{iz}}{z} dz. \\ &= 2i \int_\epsilon^R \frac{\sin(x)}{x} dx + \int_{\gamma_\epsilon} \frac{e^{iz}}{z} dz + \int_{\gamma_R} \frac{e^{iz}}{z} dz \\ &\rightarrow 2i \int_0^R \frac{\sin(x)}{x} dx - i\pi + \int_{\gamma_R} \frac{e^{iz}}{z} dz. \end{aligned}$$

as $\epsilon \rightarrow 0$. Then letting $R \rightarrow \infty$, it follows from Jordans Lemma that the third term tends to zero so we see that

$$\int_{-\infty}^{\infty} \frac{\sin(x)}{x} dx = 2 \int_0^{\infty} \frac{\sin(x)}{x} dx = \pi$$

as required.

We record a general version of the calculation we made for the contribution of the indentation to a contour in the following Lemma.

Lemma 3.7.15. *Let $f: U \rightarrow \mathbb{C}$ be a meromorphic function with a simple pole at $a \in U$ and let $\gamma_\epsilon: [\alpha, \beta] \rightarrow \mathbb{C}$ be the path $\gamma_\epsilon(t) = a + \epsilon e^{it}$, then*

$$\lim_{\epsilon \rightarrow 0} \int_{\gamma_\epsilon} f(z) dz = \text{Res}_a(f)(\beta - \alpha)i.$$

Proof. Since f has a simple pole at a , we may write

$$f(z) = \frac{c}{z-a} + g(z)$$

where $g(z)$ is holomorphic near z and $c = \text{Res}_a(f)$ (indeed $c/(z-a)$ is just the principal part of f at a). But now as g is holomorphic at a , it is

continuous at a , and so bounded. Let $M, r > 0$ be such that $|g(z)| < M$ for all $z \in B(a, r)$. Then if $0 < \epsilon < r$ we have

$$\left| \int_{\gamma_\epsilon} g(z) dz \right| \leq \ell(\gamma_\epsilon)M = (\beta - \alpha)\epsilon M,$$

which clearly tends to zero as $\epsilon \rightarrow 0$. On the other hand, we have

$$\int_{\gamma_\epsilon} \frac{c}{z-a} dz = \int_\alpha^\beta \frac{c}{\epsilon e^{it}} i\epsilon e^{it} dt = \int_\alpha^\beta (ic) dt = ic(\beta - \alpha).$$

Since $\int_{\gamma_\epsilon} f(z) dz = \int_{\gamma_\epsilon} c/(z-a) dz + \int_{\gamma_\epsilon} g(z) dz$ the result follows. \square

3.7.4 Summation of infinite series

Residue calculus can also be a useful tool in calculating infinite sums, as we now show. For this, we use the function $f(z) = \cot(\pi z)$. Note that since $\sin(\pi z)$ vanishes precisely at the integers, $f(z)$ is meromorphic with poles at each integer $n \in \mathbb{Z}$. Moreover, since f is periodic with period 1, in order to understand the poles of f it suffices to calculate the principal part of f at $z = 0$. We can use the method of the previous section to do this:

We have $\sin(z) = z - \frac{z^3}{3!} + \frac{z^5}{5!} + O(z^7)$, so that $\sin(z)$ vanishes with multiplicity 1 at $z = 0$ and we may write $\sin(z) = z(1 - zh(z))$ where $h(z) = z/3! - z^3/5! + O(z^5)$ is holomorphic at $z = 0$. Then

$$\frac{1}{\sin(z)} = \frac{1}{z}(1 - zh(z))^{-1} = \frac{1}{z} \left(1 + \sum_{n \geq 1} z^n h(z)^n \right) = \frac{1}{z} + h(z) + O(z^2).$$

Multiplying by $\cos(z)$ we see that the principal part of $\cot(z)$ is the same as that of $\frac{1}{z} \cos(z)$ which, using the Taylor expansion of $\cos(z)$, is clearly $\frac{1}{z}$ again. By periodicity, it follows that $\cot(\pi z)$ has a simple pole with residue $1/\pi$ at each integer $n \in \mathbb{Z}$.

We can also use this strategy to find further terms of the Laurent series of $\cot(z)$: Since our $h(z)$ actually vanishes at $z = 0$, the terms $h(z)^n z^n$ vanish to order $2n$. It follows that we obtain all the terms of the Laurent series of $\cot(z)$ at 0 up to order 3, say, just by considering the first two terms of the series $1 + \sum_{n \geq 1} z^n h(z)^n$, that is, $1 + zh(z)$. Since $\cos(z) = 1 - z^2/2! + z^4/4!$, it follows that $\cot(z)$ has a Laurent series

$$\begin{aligned} \cot(z) &= \left(1 - \frac{z^2}{2!} + O(z^4) \right) \cdot \left(\frac{1}{z} + \left(\frac{z}{3!} - \frac{z^3}{5!} + O(z^5) \right) \right) \\ &= \frac{1}{z} - \frac{z}{3} + O(z^3) \end{aligned}$$

The fact that $f(z)$ has simple poles at each integer will allow us to sum infinite series with the help of the following:

Lemma 3.7.16. *Let $f(z) = \cot(\pi z)$ and let Γ_N denotes the square path with vertices $(N + 1/2)(\pm 1 \pm i)$. There is a constant C independent of N such that $|f(z)| \leq C$ for all $z \in \Gamma_N^*$.*

Proof. We need to consider the horizontal and vertical sides of the square separately. Note that $\cot(\pi z) = (e^{i\pi z} + e^{-i\pi z})/(e^{i\pi z} - e^{-i\pi z})$. Thus on the horizontal sides of Γ_N where $z = x \pm (N + 1/2)i$ and $-(N + 1/2) \leq x \leq (N + 1/2)$ we have

$$\begin{aligned} |\cot(\pi z)| &= \left| \frac{e^{i\pi(x \pm (N+1/2)i)} + e^{-i\pi(x \pm (N+1/2)i)}}{e^{i\pi(x \pm (N+1/2)i)} - e^{-i\pi(x \pm (N+1/2)i)}} \right| \\ &\leq \frac{e^{\pi(N+1/2)} + e^{-\pi(N+1/2)}}{e^{\pi(N+1/2)} - e^{-\pi(N+1/2)}} \\ &= \coth(\pi(N + 1/2)). \end{aligned}$$

Now since $\coth(x)$ is a decreasing function for $x \geq 0$ it follows that on the horizontal sides of Γ_N we have $|\cot(\pi z)| \leq \coth(3\pi/2)$.

On the vertical sides we have $z = \pm(N + 1/2) + iy$, where $-N - 1/2 \leq y \leq N + 1/2$. Observing that $\cot(z + N\pi) = \cot(z)$ for any integer N and that $\cot(z + \pi/2) = -\tan(z)$, we find that if $z = \pm(N + 1/2) + iy$ for any $y \in \mathbb{R}$ then

$$|\cot(\pi z)| = |-\tan(iy)| = |-\tanh(y)| \leq 1.$$

Thus we may set $C = \max\{1, \coth(3\pi/2)\}$. □

We now show how this can be used to sum an infinite series:

Example 3.7.17. Let $g(z) = \cot(\pi z)/z^2$. By our discussion of the poles of $\cot(\pi z)$ above it follows that $g(z)$ has simple poles with residues $\frac{1}{\pi n^2}$ at each non-zero integer n and residue $-\pi/3$ at $z = 0$.

Consider now the integral of $g(z)$ around the paths Γ_N : By Lemma 3.7.16 we know $|g(z)| \leq C/|z|^2$ for $z \in \Gamma_N^*$, and for all $N \geq 1$. Thus by the estimation lemma we see that

$$\left(\int_{\Gamma_N} g(z) dz \right) \leq C(4N + 2)/(N + 1/2)^2 \rightarrow 0,$$

as $N \rightarrow \infty$. But by the residue theorem we know that

$$\int_{\Gamma_N} g(z) dz = -\pi/3 + \sum_{\substack{n \neq 0, \\ -N \leq n \leq N}} \frac{1}{\pi n^2}.$$

It therefore follows that

$$\sum_{n=1}^{\infty} \frac{1}{n^2} = \pi^2/6$$

Remark 3.7.18. Notice that the contours Γ_N and the function $\cot(\pi z)$ clearly allow us to sum other infinite series in a similar way – for example if we wished to calculate the sum of the infinite series $\sum_{n \geq 1} \frac{1}{n^2+1}$ then we would consider the integrals of $g(z) = \cot(\pi z)/(1+z^2)$ over the contours Γ_N .

Remark 3.7.19. (*Non-examinable – for interest only!*): Note that taking $g(z) = (1/z^{2k}) \cot(\pi z)$ for any positive integer k , the above strategy gives a method for computing $\sum_{n=1}^{\infty} 1/n^{2k}$ (check that you see why we need to take even powers of n). The analysis for the case $k = 1$ goes through in general, we just need to compute more and more of the Laurent series of $\cot(\pi z)$ the larger we take k to be.

One can show that $\zeta(s) = \sum_{n=1}^{\infty} 1/n^s$ converges to a holomorphic function of s for any $s \in \mathbb{C}$ with $\operatorname{Re}(s) > 1$ (as usual, we define $n^s = \exp(s \log(n))$ where \log is the ordinary real logarithm). As $s \rightarrow 1$ it can be checked that $\zeta(s) \rightarrow \infty$, however it can be shown that $\zeta(s)$ extends to a meromorphic function on all of $\mathbb{C} \setminus \{1\}$. The identity theorem shows that this extension is unique if it exists¹¹. (This uniqueness is known as the principle of “analytic continuation”.) The location of the zeros of the ζ -function is the famous Riemann hypothesis: apart from the “trivial zeros” at negative even integers, they are conjectured to all lie on the line $\operatorname{Re}(z) = 1/2$. Its values at special points however are also of interest: Euler was the first to calculate $\zeta(2k)$ for positive integers k , but the values $\zeta(2k+1)$ (for k a positive integer) remain mysterious – it was only shown in 1978 by Roger Apéry that $\zeta(3)$ is irrational for example. Our analysis above is sufficient to determine $\zeta(2k)$ once one succeeds in computing explicitly the Laurent series for $\cot(\pi z)$ or equivalently the Taylor series of $z \cot(\pi z) = iz + 2iz/(e^{2iz} - 1)$.

3.7.5 Keyhole contours

There are many ingenious paths which can be used to calculate integrals via residue theory. One common contour is known (for obvious reasons) as a *keyhole contour*. It is constructed from two circular paths of radius ϵ and R , where we let R become arbitrarily large, and ϵ arbitrarily small, and we join the two circles by line segments with a narrow neck in between. Explicitly, if $0 < \epsilon < R$ is given, pick a $\delta > 0$ small, and set $\eta_+(t) = t + i\delta$, $\eta_-(t) =$

¹¹It is this uniqueness and the fact that one can readily compute that $\zeta(-1) = -1/12$ that results in the rather outrageous formula $\sum_{n=1}^{\infty} n = -1/12$.

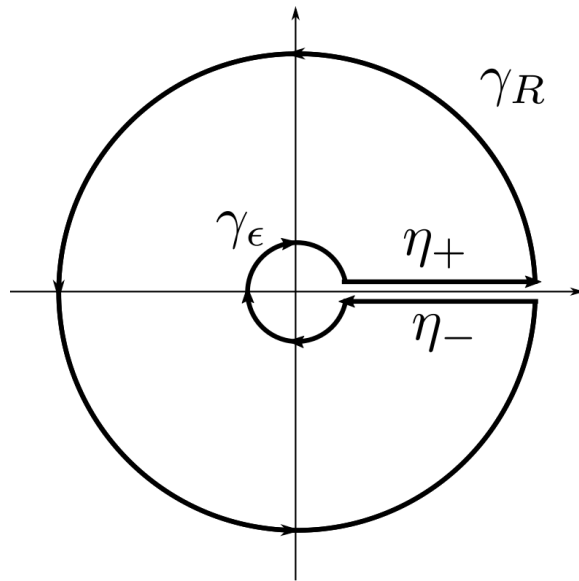

Figure 3.3: A keyhole contour.

$(R-t) - i\delta$, where in each case t runs over the closed intervals with endpoints such that the endpoints of η_{\pm} lie on the circles of radius ϵ and R about the origin. Let γ_R be the positively oriented path on the circle of radius R joining the endpoints of η_+ and η_- on that circle (thus traversing the “long” arc of the circle between the two points) and similarly let γ_{ϵ} the path on the circle of radius ϵ which is negatively oriented and joins the endpoints of η_{\pm} on the circle of radius ϵ . Then we set $\Gamma_{R,\epsilon} = \eta_+ \star \gamma_R \star \eta_- \star \gamma_{\epsilon}$ (see Figure 3.3). The keyhole contour can sometimes be useful to evaluate real integrals where the integrand is multi-valued as a function on the complex plane since it avoids a straight branch cut. We can see it in the next example:

Example 3.7.20. Consider the integral $\int_0^{\infty} \frac{x^{1/2}}{1+x^2} dx$. Let $f(z) = z^{1/2}/(1+z^2)$, where we use the branch of the square root function which is continuous on $\mathbb{C} \setminus \mathbb{R}_{>0}$, that is, if $z = re^{it}$ with $t \in [0, 2\pi)$ then $z^{1/2} = r^{1/2}e^{it/2}$.

We use the keyhole contour $\Gamma_{R,\epsilon}$. On the circle of radius R , we have $|f(z)| \leq R^{1/2}/(R^2 - 1)$, so by the estimation lemma, this contribution to the integral of f over $\Gamma_{R,\epsilon}$ tends to zero as $R \rightarrow \infty$. Similarly, $|f(z)|$ is bounded by $\epsilon^{1/2}/(1 - \epsilon^2)$ on the circle of radius ϵ , thus again by the estimation lemma this contribution to the integral of f over $\Gamma_{R,\epsilon}$ tends to zero as $\epsilon \rightarrow 0$. Finally, the discontinuity of our branch of $z^{1/2}$ on $\mathbb{R}_{>0}$ ensures that the contributions of the two line segments of the contour do not cancel but rather both tend

to $\int_0^\infty \frac{x^{1/2}}{1+x^2} dx$ as δ and ϵ tend to zero.

To compute $\int_0^\infty \frac{x^{1/2}}{1+x^2} dx$ we evaluate the integral $\int_{\Gamma_{R,\epsilon}} f(z) dz$ using the residue theorem: The function $f(z)$ clearly has simple poles at $z = \pm i$, and their residues are $\frac{1}{2}e^{-\pi i/4}$ and $\frac{1}{2}e^{-3\pi i/4}$ respectively. It follows that

$$\int_{\Gamma_{R,\epsilon}} f(z) dz = 2\pi i \left(\frac{1}{2}e^{-\pi i/4} + \frac{1}{2}e^{-3\pi i/4} \right) = \pi\sqrt{2}.$$

Taking the limit as $R \rightarrow \infty$ and $\epsilon \rightarrow 0$ we see that $2 \int_0^\infty \frac{x^{1/2}}{1+x^2} dx = \pi\sqrt{2}$, so that

$$\int_0^\infty \frac{x^{1/2} dx}{1+x^2} = \frac{\pi}{\sqrt{2}}.$$

Appendices

All appendices are non-examinable. They are here for the sake of completeness and do not form part of the syllabus.

Appendix A

On the homotopy and homology versions of Cauchy's theorem

In this appendix we give proofs of the homotopy and homology versions of Cauchy's theorem which are stated in the body of the notes. These proofs are non-examinable but are included for the sake of completeness.

We will need the following theorem that shows that certain functions defined by integrals are holomorphic.

Theorem A.0.1. *Let U be an open subset of \mathbb{C} and suppose that $F: U \times [a, b]$ is a function satisfying*

1. *The function $z \mapsto F(z, s)$ is holomorphic in z for each $s \in [a, b]$.*
2. *F is continuous on $U \times [a, b]$*

Then the function $f: U \rightarrow \mathbb{C}$ defined by

$$f(z) = \int_a^b F(z, s) ds$$

is holomorphic.

Proof. Changing variables we may assume that $[a, b] = [0, 1]$ (explicitly, one replaces s by $(s - a)/(b - a)$). By Theorem 3.3.12 it is enough to show that we may find a sequence of holomorphic functions $f_n(z)$ which converge to $f(z)$ uniformly on compact subsets of U . To find such a sequence, recall from Prelims Analysis that the Riemann integral of a continuous function is

equal to the limit of its Riemann sums as the mesh of the partition used for the sum tends to zero. Using the partition $x_i = i/n$ for $0 \leq i \leq n$ evaluating at the right-most end-point of each interval, we see that

$$f_n(z) = \frac{1}{n} \sum_{i=1}^n F(z, i/n),$$

is a Riemann sum for the integral $\int_0^1 F(z, s) ds$, hence as $n \rightarrow \infty$ we have $f_n(z) \rightarrow f(z)$ for each $z \in U$, *i.e.* the sequence (f_n) converges pointwise to f on all of U . To complete the proof of the theorem it thus suffices to check that $f_n \rightarrow f$ as $n \rightarrow \infty$ uniformly on compact subsets of U . But if $K \subseteq U$ is compact, then since F is clearly continuous on the compact set $K \times [0, 1]$, it is uniformly continuous there, hence, given any $\epsilon > 0$, there is a $\delta > 0$ such that $|F(z, s) - F(z, t)| < \epsilon$ for all $z \in \bar{B}(a, \rho)$ and $s, t \in [0, 1]$ with $|s - t| < \delta$. But then if $n > \delta^{-1}$ we have for all $z \in K$

$$\begin{aligned} |f(z) - f_n(z)| &= \left| \int_0^1 F(z, s) ds - \frac{1}{n} \sum_{i=1}^n F(z, i/n) \right| \\ &= \left| \sum_{i=1}^n \int_{(i-1)/n}^{i/n} (F(z, s) - F(z, i/n)) ds \right| \\ &\leq \sum_{i=1}^n \int_{(i-1)/n}^{i/n} |F(z, s) - F(z, i/n)| ds \\ &< \sum_{i=1}^n \epsilon/n = \epsilon. \end{aligned}$$

Thus $f_n(z)$ tends to $f(z)$ uniformly on K as required. \square

Theorem A.0.2. *Let U be a domain in \mathbb{C} and $a, b \in U$. Suppose that γ and η are paths from a to b which are homotopic in U and $f: U \rightarrow \mathbb{C}$ is a holomorphic function. Then*

$$\int_{\gamma} f(z) dz = \int_{\eta} f(z) dz.$$

Proof. The key to the proof of this theorem is to show that the integrals of f along two paths from a to b which “stay close to each other” are equal. We show this by covering both paths by finitely many open disks and using the existence of a primitive for f in each of the disks.

More precisely, suppose that $h: [0, 1] \times [0, 1]$ is a homotopy between γ and η . Let us write $K = h([0, 1] \times [0, 1])$ be the image of the map h , a

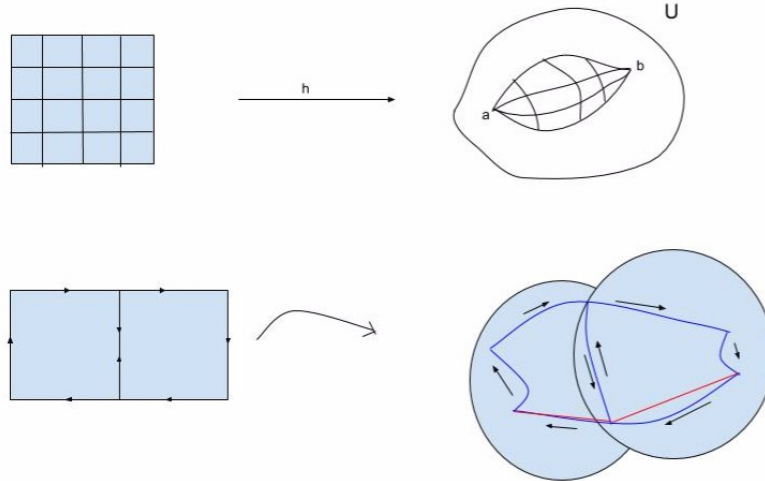

Figure A.1: Dissecting the homotopy

compact subset of U . Since K is sequentially compact there is an $\epsilon > 0$ such that $B(z, \epsilon) \subseteq U$ for all $z \in K$ (Lemma 8.2.3 of the metric spaces part of the course).

Next, we use the fact that, since $[0, 1] \times [0, 1]$ is compact, h is uniformly continuous. Thus we may find a $\delta > 0$ such that $|h(t_1, s_1) - h(t_2, s_2)| < \epsilon$ whenever $\|(t_1, s_1) - (t_2, s_2)\| < \delta$. Now pick $N \in \mathbb{N}$ such that $1/N < \delta$ and dissect the square $[0, 1] \times [0, 1]$ into N^2 small squares of side length $1/N$. For convenience, we will write $t_i = i/N$ for $i \in \{0, 1, \dots, N\}$

For each $k \in \{1, 2, \dots, N-1\}$, let ν_k be the piecewise linear path which connects the point $h(t_j, k/N)$ to $h(t_{j+1}, k/N)$ for each $j \in \{0, 1, \dots, N\}$. Explicitly, for $t \in [t_j, t_{j+1}]$, we set

$$\nu_k(t) = h(t_j, k/N)(1 - Nt - j) + h(t_{j+1}, k/N)(Nt - j)$$

We claim that

$$\int_{\gamma} f(z)dz = \int_{\nu_1} f(z)dz = \int_{\nu_2} f(z)dz = \dots = \int_{\nu_{N-1}} f(z)dz = \int_{\eta} f(z)dz$$

which will prove the theorem. In fact, we will only show that $\int_{\gamma} f(z)dz = \int_{\nu_1} f(z)dz$, since the other cases are almost identical.

We may assume the numbering of our squares S_i is such that S_1, \dots, S_N list the bottom row of our N^2 squares from left to right. Let m_i be the

centre of the square S_i and let $p_i = h(m_i)$. Then $h(S_i) \subseteq B(p_i, \epsilon)$ so that $\gamma([t_i, t_{i+1}]) \subseteq B(p_i, \epsilon)$ and $\nu_1([t_i, t_{i+1}]) \subseteq B(p_i, \epsilon)$ (since $B(p_i, \epsilon)$ is convex and by assumption contains $\nu_1(t_i)$ and $\nu_1(t_{i+1})$). Since $B(p_i, \epsilon)$ is convex, f has primitive F_i on each $B(p_i, \epsilon)$. Moreover, as primitives of f on a domain are unique up to a constant, it follows that F_i and F_{i+1} differ by a constant on $B(p_i, \epsilon) \cap B(p_{i+1}, \epsilon)$, where they are both defined. In particular, since $\gamma(t_i), \nu_1(t_i) \in B(p_i, \epsilon) \cap B(p_{i+1}, \epsilon)$, ($1 \leq i \leq N-1$), we have

$$F_i(\gamma(t_i)) - F_{i+1}(\gamma(t_i)) = F_i(\nu_1(t_i)) - F_{i+1}(\nu_1(t_i)). \quad (\text{A.0.1})$$

Now by the Fundamental Theorem we have

$$\begin{aligned} \int_{\gamma|_{[t_i, t_{i+1}]}} f(z) dz &= F_i(\gamma(t_{i+1})) - F_i(\gamma(t_i)), \\ \int_{\nu_1|_{[t_i, t_{i+1}]}} f(z) dz &= F_i(\nu_1(t_{i+1})) - F_i(\nu_1(t_i)) \end{aligned}$$

Combining we find that:

$$\begin{aligned} \int_{\gamma} f(z) dz &= \sum_{i=0}^{N-1} \int_{\gamma|_{[t_i, t_{i+1}]}} f(z) dz \\ &= \sum_{i=0}^{N-1} (F_{i+1}(\gamma(t_{i+1})) - F_{i+1}(\gamma(t_i))) \\ &= F_N(\gamma(t_N)) - F_1(\gamma(0)) + \sum_{i=1}^{N-1} (F_i(\gamma(t_i)) - F_{i+1}(\gamma(t_i))) \\ &= F_N(b) - F_0(a) + \left(\sum_{i=0}^{N-1} (F_i(\nu_1(t_{i+1})) - F_{i+1}(\nu_1(t_{i+1}))) \right) \\ &= \sum_{i=0}^{N-1} ((F_{i+1}(\nu_1(t_{i+1})) - F_{i+1}(\nu_1(t_i))) \\ &= \sum_{i=0}^{N-1} \int_{\nu_1|_{[t_i, t_{i+1}]}} f(z) dz = \int_{\nu_1} f(z) dz \end{aligned}$$

where in the fourth equality we used Equation (A.0.1). \square

Remark A.0.3. The use of the piecewise linear paths ν_k might seem unnatural – it might seem simpler to use the paths given by the homotopy, that is the paths $\gamma_k(t) = h(t, k/N)$. The reason we did not do this is because

we only assume that h is continuous, so we do not know that the path γ_k is piecewise C^1 which we need in order to be able to integrate along it.

The proof of the homology form of Cauchy's theorem uses Liouville's theorem, which we proved using Cauchy's theorem for a disc.

Theorem A.0.4. *Let $f: U \rightarrow \mathbb{C}$ be a holomorphic function and let $\gamma: [0, 1] \rightarrow U$ be a closed path whose inside lies entirely in U , that is $I(\gamma, z) = 0$ for all $z \notin U$. Then we have, for all $z \in U \setminus \gamma^*$,*

$$\int_{\gamma} f(\zeta) d\zeta = 0; \quad \int_{\gamma} \frac{f(\zeta)}{\zeta - z} d\zeta = 2\pi i I(\gamma, z) f(z), \quad \forall z \in U \setminus \gamma^*.$$

Moreover, if U is simply connected and $\gamma: [a, b] \rightarrow U$ is any closed path, then $I(\gamma, z) = 0$ for any $z \notin U$, so the above identities hold for all closed paths in such U .

Proof. We first prove the general form of the integral formula. Note that using the integral formula for the winding number and rearranging, we wish to show that

$$F(z) = \int_{\gamma} \frac{f(\zeta) - f(z)}{\zeta - z} d\zeta = 0$$

for all $z \in U \setminus \gamma^*$. Now if $g(\zeta, z) = (f(\zeta) - f(z))/(\zeta - z)$, then since f is complex differentiable, g extends to a continuous function on $U \times U$ if we set $g(z, z) = f'(z)$. Thus the function F is in fact defined for all $z \in U$. Moreover, if we fix ζ then, by standard properties of differentiable functions, $g(\zeta, z)$ is clearly complex differentiable as a function of z everywhere except at $z = \zeta$. But since it extends to a continuous function at ζ , it is bounded near ζ , hence by Riemann's removable singularity theorem, $z \mapsto g(\zeta, z)$ is in fact holomorphic on all of U . It follows by Theorem A.0.1 that

$$F(z) = \int_0^1 g(\gamma(t), z) \gamma'(t) dt$$

is a holomorphic function of z .

Now let $\text{ins}(\gamma) = \{z \in \mathbb{C} : I(\gamma, z) \neq 0\}$ be the inside of γ , so by assumption we have $\text{ins}(\gamma) \subset U$, and let $V = \mathbb{C} \setminus (\gamma^* \cup \text{ins}(\gamma))$ be the complement of γ^* and its inside. If $z \in U \cap V$, that is, $z \in U$ but not inside γ or on γ^* ,

then

$$\begin{aligned} F(z) &= \int_{\gamma} \frac{f(\zeta)d\zeta}{\zeta - z} - f(z) \int_{\gamma} \frac{d\zeta}{\zeta - z} \\ &= \int_{\gamma} \frac{f(\zeta)d\zeta}{\zeta - z} - f(z)I(\gamma, z) \\ &= \int_{\gamma} \frac{f(\zeta)d\zeta}{\zeta - z} = G(z) \end{aligned}$$

since $I(\gamma, z) = 0$. Now $G(z)$ is an integral which only involves the values of f on γ^* hence it is defined for all $z \notin \gamma^*$, and by Theorem A.0.1, $G(z)$ is holomorphic. In particular, G defines a holomorphic function on V , which agrees with F on all of $U \cap V$, and thus gives an extension of F to a holomorphic function on all of \mathbb{C} . (Note that by the above, F and G will in general *not* agree on the inside of γ .) Indeed if we set $H(z) = F(z)$ for all $z \in U$ and $H(z) = G(z)$ for all $z \in V$ then H is a well-defined holomorphic function on all of \mathbb{C} . We claim that $|H| \rightarrow 0$ as $|z| \rightarrow \infty$, so that by Liouville's theorem, $H(z) = 0$, and so $F(z) = 0$ as required. But since $\text{ins}(\gamma)$ is bounded, there is an $R > 0$ such that $V \supseteq \mathbb{C} \setminus B(0, R)$, and so $H(z) = G(z)$ for $|z| > R$. But then setting $M = \sup_{\zeta \in \gamma^*} |f(\zeta)|$ we see

$$|H(z)| = \left| \int_{\gamma} \frac{f(\zeta)d\zeta}{\zeta - z} \right| \leq \frac{\ell(\gamma) \cdot M}{|z| - R}.$$

which clearly tends to zero as $|z| \rightarrow \infty$, hence $|H(z)| \rightarrow 0$ as $|z| \rightarrow \infty$ as required.

For the second formula, simply apply the integral formula to $g(z) = (z - w)f(z)$ for any $w \notin \gamma^*$. Finally, to see that if U is simply connected the inside of γ always lies in U , note that if $w \notin U$ then $1/(z - w)$ is holomorphic on all of U , and so $I(\gamma, w) = \int_{\gamma} \frac{dz}{z - w} = 0$ by the homotopy form of Cauchy's theorem. \square

Remark A.0.5. It is often easier to check that a domain is simply connected than it is to compute the interior of a path. Note that the above proof uses Liouville's theorem, whose proof depends on Cauchy's Integral Formula for a circular path, which was a consequence of Cauchy's theorem for a triangle, but apart from the final part of the proof on simply connected regions, we did not use the more sophisticated homotopy form of Cauchy's theorem. We have thus established the winding number and homotopy forms of Cauchy's theorem essentially independently of each other.

Appendix B

Remark on the Inverse Function Theorem

In this appendix we supply¹ the details for the claim made in the remark after the proof of the holomorphic version of the inverse function theorem.

There is an enhancement of the Inverse Function Theorem in the holomorphic setting, which shows that the condition $f'(z) \neq 0$ is automatic (in contrast to the case of real differentiable functions, where it is essential as one sees by considering the example of the function $f(x) = x^3$ on the real line). Indeed suppose that $f: U \rightarrow \mathbb{C}$ is a holomorphic function on an open subset $U \subset \mathbb{C}$, and that we have $z_0 \in U$ such that $f'(z_0) = 0$.

Claim: In this case, f is at least 2 to 1 near z_0 , and hence is not injective.

Proof of Claim: If we let $w_0 = f(z_0)$ and $g(z) = f(z) - w_0$, it follows g has a zero at z_0 , and thus it is either identically zero on the connected component of U containing z_0 (in which case it is very far from being injective!) or we may write $g(z) = (z - z_0)^k h(z)$ where $h(z)$ is holomorphic on U and $h(z_0) \neq 0$. Our assumption that $f'(z_0) = 0$ implies that k , the multiplicity of the zero of g at z_0 is at least 2.

Now since $h(z_0) \neq 0$, we have $\epsilon = |h(z_0)| > 0$ and hence by the continuity of h at z_0 we may find a $\delta > 0$ such that $h(B(z_0, \delta)) \subseteq B(h(z_0), \epsilon)$. But then by taking a cut along the ray $\{-t.h(z_0) : t \in \mathbb{R}_{>0}\}$ we can define a holomorphic branch of $z \mapsto z^{1/k}$ on the whole of $B(h(z_0), \epsilon)$. Now let $\phi: B(z_0, \delta) \rightarrow \mathbb{C}$ be the holomorphic function given by $\phi(z) = (z - z_0).h(z)^{1/k}$ (where by our choice of δ this is well-defined) so that $\phi'(z_0) = h(z_0)^{1/k} \neq 0$. Then clearly $f(z) = w_0 + \phi(z)^k$ on $B(z_0, \delta)$. Since $\phi(z)$ is holomorphic, the

¹For interest, not examination!

open mapping theorem ensures that $\phi(B(z_0, \delta))$ is an open set, which since it contains $0 = \phi(z_0)$, contains $B(0, r)$ for some $r > 0$. But then since $z \mapsto z^k$ is k -to-1 as a map from $B(0, r) \setminus \{0\} \rightarrow B(0, r^k) \setminus \{0\}$ it follows that f takes every value in $B(w_0, r^k) \setminus \{w_0\}$ at least k times.